

Radio - BUILD A STEREO-TV DECODER

SPECIAL SECTION: PERSONAL ROBOTICS

\$1.95 MAR. 1986
IN CANADA \$2.53

Electronics

TECHNOLOGY - VIDEO - STEREO - COMPUTERS - SERVICE

A BUYER'S GUIDE TO PERSONAL ROBOTICS

We'll show you what's available.

A GERNSBACK PUBLICATION

GETTING STARTED IN ROBOTICS

We'll show you what's involved.

BUILD A WALKMAN AMPLIFIER

BIG sound from your personal stereo!

BUILD R-E's VIDEO TITLER

Add new life to your videotapes.

HOW TO SERVICE CD PLAYERS

A troubleshooting guide.

DON'T LET HEAT DESTROY YOUR PROJECTS

We'll show you how to keep things cool.



PLUS:

- ★ Ask R-E
- ★ TV Troubleshooting Solutions
- ★ Robotics
- ★ New Ideas
- ★ Radios
- ★ COMPUTER DIGIT

*542A*****S-DIGIT 07003
 1590012 CAR 0023B093 14 R OCT186
 03*06
 MICHAEL J CLARSON
 23 BROAD TER
 BLOOMFIELD NJ 07003

100 MHz scope, counter, timer, multimeter: All one integrated system.

100 MHz dual time base scope. 3.5 ns risetime, sweeps from 0.5 s to 5 ns/div; alternate sweep; $\pm 2\%$ vertical/horizontal accuracy; vertical sensitivity to 2 mV/div @ 90 MHz.

9-digit fluorescent display. Digitally accurate readouts accompany the CRT waveform. Error messages and prompts also appear on the display.

Dc volts and ac coupled true RMS volts. Measured through the Ch 1 scope input.

Gated measurements. Use the scope's intensified marker to measure frequency, period, width and to count events within specified portions of the signal.

Auto-ranged, auto-averaged counter/timer. Frequency, period, width, delay time, Δ -time, plus totalize to more than 8 million events—with 7 digits plus exponent displayed.

Auto-ranged DMM. Use floating DMM side inputs with up to 5000-count resolution. Get precise readouts of average dc and true RMS voltage. Measure resistance from milliohms to gigohms.

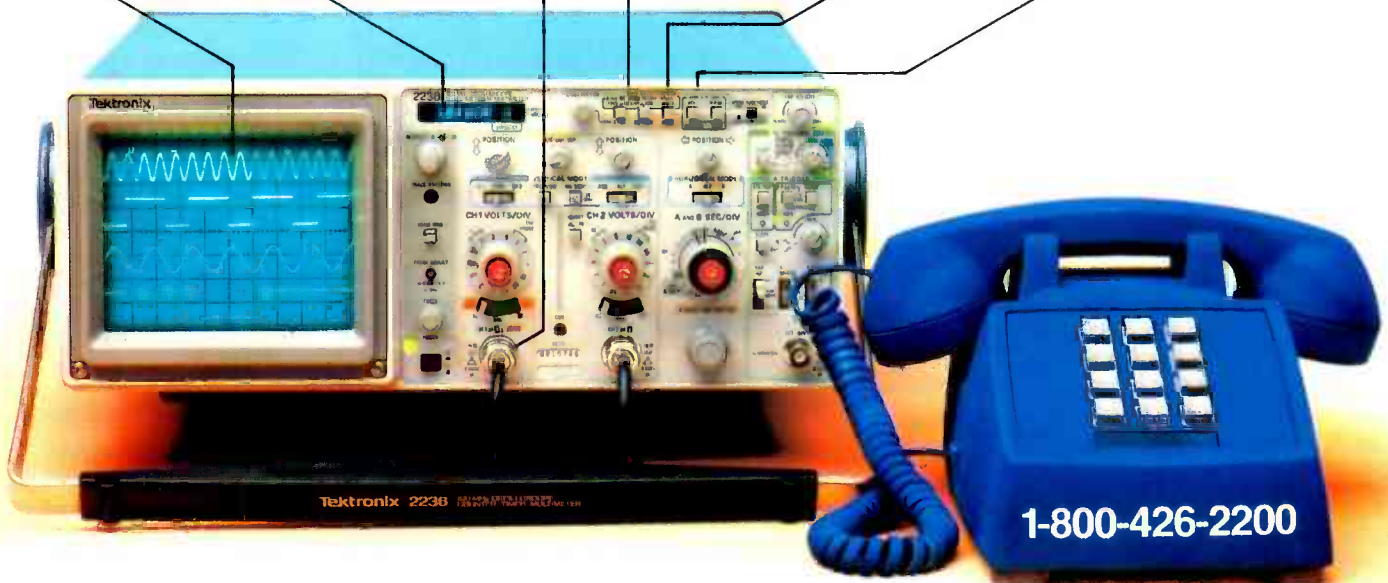

Now make measurements faster, easier, with greater accuracy and user confidence. The Tek 2236 makes gated counter measurements, temperature, time, frequency, resistance and voltage measurements push-button easy. You see results concurrently on the 9-digit numeric readout and CRT display.

Its complete trigger system includes pushbutton trigger view, plus peak-to-peak auto, TV line, TV field, single sweep and normal modes.

At just \$2650* the 2236 includes the industry's first 3-year warranty on all parts and labor, including the CRT.

Integrated measurement system. 3-year warranty. 15-day return policy. And expert advice. One free call gets it all! You can order, or obtain literature, through the Tek National Marketing Center. Technical personnel, expert in scope applications, can answer your questions and expedite delivery. Direct orders include probes, operating

manual, 15-day return policy, full warranty and worldwide service back-up.

Order toll-free: 1-800-426-2200 Extension 57

In Oregon call collect: (503) 627-9000 Ext. 57
Or write Tektronix, Inc.
P.O. Box 1700
Beaverton, OR 97075

Tektronix®
COMMITTED TO EXCELLENCE

MARCH '86

**Radio-
Electronics**

Electronics publishers since 1908

Vol. 57 No. 3

SPECIAL SECTION

- 41 BUYER'S GUIDE TO PERSONAL ROBOTS**
A comprehensive guide to the robotics marketplace. **Mark Robillard**
- 47 BUILDING YOUR OWN ROBOT**
Helpful hints to get you started.
Mark Robillard

BUILD THIS

- 51 STEREO TV DECODER**
It's easier than you think to double your listening pleasure! **Steve Sokolowski**
- 59 WALKMAN AMPLIFIER**
Get big home-stereo sound from your personal portable stereo.
- 62 VIDEO TITLER**
Part 4. Make the video titler even more versatile by interfacing it to your computer.
Jack Flack
- 79 PC SERVICE**
Use these direct-etch foil patterns to make circuit boards for your walkman amplifier and stereo-TV decoder.

TECHNOLOGY

- 12 VIDEO NEWS**
A review of the fast-changing video scene.
David Lachenbruch
- 81 SATELLITE TV**
Surviving a hurricane. **Bob Cooper, Jr.**
- 67 HEAT-PROOFING YOUR PROJECTS**
Part 2. The latest technology to fight overheating.
Vaughn D. Martin and Billy W. Davis
- 73 REPAIRING COMPACT DISC PLAYERS**
Part 5. How CD players work—and what to do when they don't. **John D. Lenk**

CIRCUITS AND COMPONENTS

- 76 TROUBLESHOOTING THE TOUGH ONES**
Some case histories of hard-to-troubleshoot TV problems. **Frank A. Salerno**
- 94 STATE OF SOLID STATE**
Overvoltage protection. **Robert F. Scott**
- 88 DRAWING BOARD**
A demonstration program for our Z80 circuit.
Robert Grossblatt
- 90 DESIGNER'S NOTEBOOK**
Winning single-gate designs.
Robert Grossblatt

RADIO

- 86 ANTIQUE RADIOS**
The early history of radio.
Richard D. Fitch
- 92 COMMUNICATIONS CORNER**
Networking the nation.
Herb Friedman

VIDEO

- 84 SERVICE CLINIC**
Troubleshooting voltage regulator circuits. **Jack Darr**
- 85 SERVICE QUESTIONS**
Answers to your TV-service questions.

COMPUTERS

- Following page 86 **COMPUTER DIGEST**
Printers, graphics adapters, and more.

EQUIPMENT REPORTS

- 22 G-E Control Central Programmable Remote Control System**
- 28 Uniden-Bearcat 800XLT Scanner**

DEPARTMENTS

- 118 Advertising and Sales Offices**
- 118 Advertising Index**
- 8 Ask R-E**
- 4 Editorial**
- 119 Free Information Card**
- 14 Letters**
- 96 Market Center**
- 30 New Products**
- 6 What's News**

Radio-Electronics, (ISSN 0033-7862) March 1986. Published monthly by Gernsback Publications, Inc., 500-B Bi-County Boulevard, Farmingdale, NY 11735 Second-Class Postage paid at Farmingdale, NY and additional mailing offices. Second-Class mail registration No. 9242 authorized at Toronto, Canada. One-year subscription rate U.S.A. and possessions \$15.97, Canada \$20.97, all other countries \$23.47. Subscription orders payable in U.S. funds only. international postal money order or check drawn on a U.S.A. bank. Single copies \$1.95. © 1986 by Gernsback Publications, Inc. All rights reserved. Printed in U.S.A.

POSTMASTER: Please send address changes to RADIO-ELECTRONICS, Subscription Dept., Box 2520, Boulder, CO 80322.

A stamped self-addressed envelope must accompany all submitted manuscripts and/or artwork or photographs if their return is desired should they be rejected. We disclaim any responsibility for the loss or damage of manuscripts and/or artwork or photographs while in our possession or otherwise.

COVER 1



You want to know more about robots but can't find any information? Well it's all here in two special articles that cover the state of personal robots in depth. First, we'll show you what's available in the marketplace: kits, assembled units, arms, rovers, turtles, and more. Second, we'll show you what's involved in building a robot from scratch. The special section starts on page 41.

The robot you see featured on the cover is the *Gemini* from Artec systems of Columbia, Maryland. It's a sophisticated robot rover with built-in intelligence. It talks and listens. It will recharge its batteries when it senses it's getting low on power. The entire robot is available in kit form, and its subassemblies are available separately. It's just one of the robots we cover in this issue.

NEXT MONTH

THE APRIL ISSUE IS
ON SALE MARCH 4

GET INTO TELETEXT

We'll introduce you to World System Teletext and then we'll show you how to build a teletext decoder so that you can join the fun.

BUILD A TELEPHONE-LINE TESTER

Save on unnecessary repair costs by keeping tabs on your phone line.

GRAVITY WAVES?

Are gravitational waves the source of $1/f$ noise in electronic components?

ALL ABOUT FREQUENCY COUNTERS

How to choose and use this valuable test instrument.

As a service to readers, Radio-Electronics publishes available plans or information relating to newsworthy products, techniques and scientific and technological developments. Because of possible variances in the quality and condition of materials and workmanship used by readers, Radio-Electronics disclaims any responsibility for the safe and proper functioning of reader-built projects based upon or from plans or information published in this magazine.

Since some of the equipment and circuitry described in RADIO-ELECTRONICS may relate to or be covered by U.S. patents, RADIO-ELECTRONICS disclaims any liability for the infringement of such patents by the making, using, or selling of any such equipment or circuitry, and suggests that anyone interested in such projects consult a patent attorney.

Radio-Electronics

Hugo Gernsback (1884-1967) founder
M. Harvey Gernsback,
editor-in-chief, emeritus

Larry Steckler, EHF, CET, publisher

EDITORIAL DEPARTMENT

Larry Steckler, editor-in-chief

Art Kleiman, editorial director

Brian C. Fenton, managing editor

Carl Laron, WB2SLR, associate editor

Jeffrey K. Holtzman,
assistant technical editor

Robert A. Young, assistant editor

Julian S. Martin, editorial associate

Byron G. Wels, editorial associate

M. Harvey Gernsback,
contributing editor

Jack Darr, CET, service editor

Robert F. Scott,
semiconductor editor

Herb Friedman,
communications editor

Bob Cooper, Jr. satellite-TV editor

Robert Grossblatt, circuits editor

David Lachenbruch,
contributing editor

Richard D. Fitch,
contributing editor

Mark J. Robillard, robotics editor

Bess Isaacson, editorial assistant

PRODUCTION DEPARTMENT

Ruby M. Yee, production director

Robert A. W. Lowndes,
editorial production

Andre Duzant, technical illustrator

Karen Tucker, advertising production

Geoffrey S. Weil, production traffic

CIRCULATION DEPARTMENT

Jacqueline P. Cheeseboro,
circulation director

Rita Sabalis,
assistant circulation director

Jacqueline Allen, circulation assistant

Cover photo by Robert Lewis

Typography by Mates Graphics

Radio-Electronics is indexed in
Applied Science & Technology Index
and *Readers Guide to Periodical Literature*.

Microfilm & Microfiche editions are
available. Contact circulation department
for details.

Advertising Sales Offices listed
on page 118.



NEW! Lower Price Scanners

Communications Electronics,TM the world's largest distributor of radio scanners, introduces new lower prices to celebrate our 15th anniversary.

Regency[®] MX7000-DA

List price \$699.95/CE price \$394.95/SPECIAL
10-Band, 20 Channel • Crystalless • AC/DC
Frequency range: 25-550 MHz. continuous coverage and 800 MHz. to 1.3 GHz. continuous coverage
The Regency MX7000 scanner lets you monitor military, F.B.I., Space Satellites, Police and Fire Departments, Drug Enforcement Agencies, Defense Department, Aeronautical, AM band, Aero Navigation Band, Fish & Game, Immigration, Paramedics, Amateur Radio, Justice Department, State Department, plus thousands of other radio frequencies most scanners can't pick up. The Regency MX7000 is the perfect scanner for intelligence agencies that need to monitor the new 800 MHz. cellular telephone band. The MX7000, now at a special price from CE.

Regency[®] Z60-DA

List price \$379.95/CE price \$179.95/SPECIAL
8-Band, 60 Channel • No-crystal scanner
Bands: 30-50, 88-108, 118-136, 144-174, 440-512 MHz
Hear Police, Aircraft and the FM Broadcast Bands. The Regency Z60 covers all the public service bands plus aircraft and FM music for a total of eight bands. The Z60 also features an alarm clock and priority control as well as AC/DC operation. Order today.

Regency[®] Z45-DA

List price \$329.95/CE price \$159.95/SPECIAL
7-Band, 45 Channel • No-crystal scanner
Bands: 30-50, 118-136, 144-174, 440-512 MHz.
The Regency Z45 is very similar to the Z60 model listed above however it does not have the commercial FM broadcast band. The Z45, now at a special price from Communications Electronics Inc.

Regency[®] RH250B-DA

List price \$613.00/CE price \$329.95/SPECIAL
10 Channel • 25 Watt Transceiver • Priority
The Regency RH250B is a ten-channel VHF land mobile transceiver designed to cover any frequency between 150 to 162 MHz. Since this radio is synthesized, no expensive crystals are needed to store up to ten frequencies without battery backup. All radios come with CTCSS tone and scanning capabilities. A monitor and night/day switch is also standard. This transceiver even has a priority function. The RH250 makes an ideal radio for any police or fire department volunteer because of its low cost and high performance. A UHF version of the same radio called the RU150B covers 450-482 MHz, but the cost is \$449.00. To get technician programming instructions, order a service manual from CE with your radio system.

NEW! Bearcat[®] 50XL-DA

List price \$199.95/CE price \$114.95/SPECIAL
10-Band, 10 Channel • Handheld scanner
Bands: 29.7-54, 136-174, 406-512 MHz.
The Uniden Bearcat 50XL is an economical, hand-held scanner with 10 channels covering ten frequency bands. It features a keyboard lock switch to prevent accidental entry and more. Also order part # **BP50** which is a rechargeable battery pack for \$14.95, a plug-in wall charger, part # **AD100** for \$14.95 and also order optional cigarette lighter cable part # **PS001** for \$14.95.

NEW! JIL SX-400-DA

List price \$799.95/CE price \$399.95/SPECIAL
Multi-Band, 20 Channel • No-crystal Scanner
Search • Lockout • Priority • AC/DC
Frequency range: 26-520 MHz. continuous coverage.
With optionally equipped RF converters 150KHz-3.7 GHz.
To celebrate our 15th anniversary, when you order the JIL SX-400 synthesized scanner before March 31, 1986, from CE, you'll get your choice of the RF-8014-DA or RF-5080-DA converter free. Or if you prefer, you can get the RF-1030-DA converter for only \$50.00 more with your SX-400 order. The JIL SX-400 is designed for commercial and professional monitor uses that demand features not found in ordinary scanners. The SX-400 will cover from 150 KHz to 3.7 GHz. with RF converters. You may also order the following RF converters for your SX-400 scanners separately at these prices.
RF-1030-DA at \$234.95 each for frequency range 150 KHz - 30 MHz. USB, LSB, CW and AM (CW filter required for CW signal reception). **RF-5080-DA** at \$194.95 each for 500-800 MHz. **RF-8014-DA** at \$194.95 each for 800 MHz-1.4 GHz. Be sure to also order **ACB-300-DA** at \$99.95 each which is an antenna control box for connection of the RF converters. The **RC-4000-DA** data interface at \$259.95 each gives you control of the SX-400 scanner and RF converters through a computer. Add \$3.00 shipping for each RF converter, data interface or antenna control box. Add \$10.00 for shipping both the scanner and free converters. If you need further information on the JIL scanners, contact JIL directly at 213-926-6727 or write JIL, at 17120 Edwards Road, Cerritos, California 90701.

SPECIAL! JIL SX-200-DA

List price \$499.95/CE price \$157.95/SPECIAL
Multi-Band - 16 Channel • No-Crystal Scanner
Frequency range 26-88, 108-180, 380-514 MHz.
The JIL SX-200 has selectable AM/FM receiver circuits, tri-switch squelch settings - signal, audio and signal & audio, outdoor AC power supply - DC at 12 volts built-in, quartz clock - bright vacuum fluorescent blue read-outs and dimmer, dual level search speeds, tri-level scan delay switches, 16 memory channels in two channels banks, receive fine tune (RT) ± 2KHz., dual level RF gain settings - 20 db pad, AGC test points for optional signal strength meters all for this special price.

NEW! Regency[®] HX1200-DA

List price \$369.95/CE price \$219.95/SPECIAL
8-Band, 45 Channel • No Crystal scanner
Search • Lockout • Priority • Scan delay
Sidelit liquid crystal display • EAROM Memory
New Direct Channel Access Feature
Bands: 30-50, 118-136, 144-174, 406-420, 440-512 MHz.
The new handheld Regency HX1200 scanner is fully keyboard programmable for the ultimate in versatility. You can scan up to 45 channels at the same time including the AM aircraft band. The LCD display is even sidelit for night use. Order **MA-256-DA** rapid charge drop-in battery charger for \$68.95 plus \$3.00 shipping/handling. Includes wall charger, carrying case, belt clip, flexible antenna and nicad battery.

NEW! Bearcat[®] 100XL-DA

List price \$349.95/CE price \$209.95/SPECIAL
9-Band, 16 Channel • Priority • Scan Delay
Search • Limit • Hold • Lockout • AC/DC
Frequency range: 30-50, 118-174, 406-512 MHz.
The world's first no-crystal handheld scanner now has a LCD channel display with backlight for low light use and aircraft band coverage at the same low price. Size is 1 3/4" x 7 1/2" x 2 7/8". The Bearcat 100XL has wide frequency coverage that includes all public service bands (Low, High, UHF and "T" bands), the AM aircraft band, the 2-meter and 70 cm. amateur bands, plus military and federal government frequencies. Wow... what a scanner!
Included in our low CE price is a sturdy carrying case, earphone, battery charger/AC adapter, six AA ni-cad batteries and flexible antenna. Order your scanner now.

Bearcat[®] 210XW-DA

List price \$339.95/CE price \$209.95/SPECIAL
8-Band, 20 Channel • No-crystal scanner
Automatic Weather • Search/Scan • AC/DC
Frequency range: 30-50, 136-174, 406-512 MHz.
The new Bearcat 210XW is an advanced third generation scanner with great performance at a low CE price.

NEW! Bearcat[®] 145XL-DA

List price \$179.95/CE price \$102.95/SPECIAL
10 Band, 16 channel • AC/DC • Instant Weather
Frequency range: 29-54, 136-174, 420-512 MHz.
The Bearcat 145XL makes a great first scanner. Its low cost and high performance lets you hear all the action with the touch of a key. Order your scanner from CE today.

NEW! Bearcat[®] 800XL-DA

List price \$499.95/CE price \$317.95
12-Band, 40 Channel • No-crystal scanner
Priority control • Search/Scan • AC/DC
Bands: 29-54, 118-174, 406-512, 806-912 MHz.
The Uniden 800XL receives 40 channels in two banks. Scans 15 channels per second. Size 9 1/4" x 4 1/2" x 1 1/2".

OTHER RADIOS AND ACCESSORIES

Panasonic RF-2600-DA Shortwave receiver	\$179.95
Panasonic RF-B300-DA Shortwave receiver	\$195.95
RD95-DA Uniden Remote mount Radar Detector	\$128.95
RD55-DA Uniden Visor mount Radar Detector	\$98.95
RD9-DA Uniden "Passport" size Radar Detector	\$239.95
BC 210XW-DA Bearcat 20 channel scanner SALE	\$209.95
BC-WA-DA Bearcat Weather Alert	\$49.95
DX1000-DA Bearcat shortwave receiver SALE	\$349.95
PC22-DA Uniden remote mount CB transceiver	\$99.95
PC55-DA Uniden mobile mount CB transceiver	\$59.95
R1060-DA Regency 10 channel scanner	\$98.95
MX3000-DA Regency 30 channel scanner	\$198.95
XLI56-DA Regency 10 channel scanner SALE	\$129.95
UC102-DA Regency VHF 2 chan. 1 Watt transceiver	\$124.95
RH250B-DA Regency 10 ch. 25 Watt VHF transceiver	\$329.95
RH600B-DA Regency 10 ch. 60 Watt VHF transceiver	\$454.95
RU150B-DA Regency 10 channel UHF transceiver	\$449.95
RPH410-DA 10 ch. handheld no-crystal transceiver	\$399.95
P1405-DA Regency 5 amp regulated power supply	\$69.95
P1412-DA Regency 12 amp regulated power supply	\$119.95
BC10-DA Battery charger for Regency RPH410	\$79.95
MA256-DA Drop-in charger for HX1000 & HX1200	\$68.95
MA257-DA Cigarette lighter cord for HX1200	\$19.95
MA917-DA Ni-Cad battery pack for HX1200	\$34.95
EC10-DA Programming tool for Regency RPH410	\$24.95
SMRH250-DA Service man. for Regency RH250	\$24.95
SMRU150-CA Service man. for Regency RU150	\$24.95
SMRPH410-DA Service man. for Regency RPH410	\$24.95
SMMX7000-DA Svc. man. for MX7000 & MX5000	\$19.95
SMMX3000-DA Service man. for Regency MX3000	\$19.95
B-4-DA 1.2 V AAA Ni-Cad batteries (set of four)	\$9.00
A-135C-DA Crystal certificate	\$3.00
FB-E-DA Frequency Directory for Eastern U.S.A.	\$12.95
FB-W-DA Frequency Directory for Western U.S.A.	\$12.95
TSG-DA "Top Secret" Registry of U.S. Govt. Freq.	\$14.95
TIC-DA Techniques for Intercepting Comm.	\$14.95
RRF-DA Railroad frequency directory	\$10.95
CIE-DA Covert Intelligence. Elect. Eavesdropping	\$14.95
A60-DA Magnet mount mobile scanner antenna	\$35.00
A70-DA Base station scanner antenna	\$35.00
USAMM-DA Mag mount VHF/UHF ant. w/ 12' cable	\$39.95
USAK-DA 3/4" hole mount VHF/UHF ant. w/ 17' cable	\$35.00
USATLM-DA Trunk lip mount VHF/UHF antenna	\$35.00

Add \$3.00 shipping for all accessories ordered at the same time.
Add \$12.00 shipping per shortwave receiver.
Add \$7.00 shipping per scanner and \$3.00 per antenna.

BUY WITH CONFIDENCE

To get the fastest delivery from CE of any scanner, send or phone your order directly to our Scanner Distribution Center. Michigan residents please add 4% sales tax or supply your tax I.D. number. Written purchase orders are accepted from approved government agencies and most well rated firms at a 10% surcharge for net 10 billing. All sales are subject to availability, acceptance and verification. All sales on accessories are final. Prices, terms and specifications are subject to change without notice. All prices are in U.S. dollars. Out of stock items will be placed on backorder automatically unless CE is instructed differently. A \$5.00 additional handling fee will be charged for all orders with a merchandise total under \$50.00. Shipments are F.O.B. Ann Arbor, Michigan. No COD's. Most products that we sell have a manufacturer's warranty. Free copies of warranties on these products are available prior to purchase by writing to CE. Non-certified checks require bank clearance.

Mail orders to: Communications Electronics, Box 1045, Ann Arbor, Michigan 48106 U.S.A. Add \$7.00 per scanner for U.P.S. ground shipping and handling in the continental U.S.A. For Canada, Puerto Rico, Hawaii, Alaska, or APO/FPO delivery, shipping charges are three times continental U.S. rates. If you have a Visa or Master Card, you may call and place a credit card order. Order toll-free in the U.S. Dial 800-USA-SCAN. In Canada, order toll-free by calling 800-221-3475. Telex CE anytime, dial 810-223-2422. If you are outside the U.S. or in Michigan dial 313-973-8888. Order today.

Scanner Distribution Center[™] and CE logos are trademarks of Communications Electronics Inc.

* Bearcat is a registered trademark of Uniden Corporation.
† Regency is a registered trademark of Regency Electronics Inc.
AD #021586-DA

Copyright © 1986 Communications Electronics Inc.

For credit card orders call
1-800-USA-SCAN

**COMMUNICATIONS
ELECTRONICS INC.**

Consumer Products Division
P.O. Box 1045 □ Ann Arbor, Michigan 48106-1045 U.S.A.
Call 800-USA-SCAN or outside U.S.A. 313-973-8888

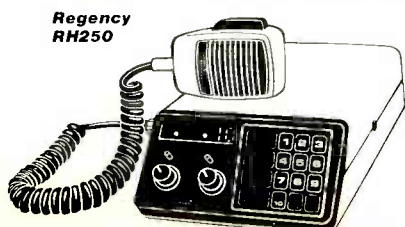

CIRCLE 79 ON FREE INFORMATION CARD

It's about JOBS It's about MONEY

The U.S. Labor Department, in their 1984 Occupational Projections and Training Data report, predicts that 589,000 positions will need to be filled by 1995.

Isn't it about TIME

To prepare for an interesting and rewarding career in
COMPUTER TECHNOLOGY
TELECOMMUNICATIONS
OR ROBOTICS?

Isn't it about time to invest in YOU?

We Offer:

- Training that keeps pace with each new advancement
- Facilities that are modern, attractive and comfortable
- Amenities and services to promote your success
- Financial assistance is available
- And once you graduate, placement assistance is also available

*Phoenix Institute
of Technology* 

2555 E. University Drive
Phoenix, Arizona 85034
(602) 244-8111

For more information about careers in Electronics Technology, address inquiries to Admissions Department

Name _____

Address _____

City _____

State _____ Zip _____

Phone () _____

EDITORIAL

Where is the "robotics revolution?"

The robotics revolution that has been promised for decades has been a long time coming. We'll be the first to admit that you shouldn't expect to see it any time soon. Why, then, are we dedicating two feature articles to personal robots?

The answer is simple; it's the same reason we started publishing microprocessor and computer articles when most computers were seen only in science-fiction movies and books. We believe that the readers of **Radio-Electronics** deserve to be informed *first* about about new electronics technology.

Even though there are more than 15,000 industrial robots installed in the United States, personal robotics is still in its infancy. But the field has come a long way since we published our Unicorn-1 construction story back about five years ago. For example, the Robotics Industries Association, once dedicated to the industrial-robotics community, has started a National Personal Robot Association (NRPA). They see the potential for robots in education and entertainment, and even doing household chores.

There is still a lot of work to be done in such areas as machine vision, voice recognition, and tactile sensing. And without the proper standards for electrical interfaces, mechanical interlaces, human interfaces, and safety, the robotics revolution will never get off the ground.

Unfortunately, the proper standards are not enough to carry personal robotics out of its infancy. But one revolutionary product could turn things around. The field of robotics incorporates so many areas of specialties, that almost everyone can find one that interests him. And I'm writing this editorial in the hopes that it will convince someone to turn his attention to robotics. Who knows? *You* may be the one to develop that one revolutionary product that will turn things around.



Brian C. Fenton
Managing Editor



ELECTRONICS, INC.

New and Used Electronic Test Equipment
Sales • Service • Rental • Leasing

HITACHI 3.5 Digit DMM *Free* With Scope Purchase



FEATURES:

- AC DC voltage
- AC DC current
- Resistance
- Diode test
- Audible Continuity check
- Temperature (Type K, 3510 & 3525)
- Data hold
- Manual or autoranging
- Overload protection
- LCD display
- Built-in stand
- Battery included
- Test leads included

Special!

MODEL	BASIC DC VOLTAGE ACCURACY	QTY 1 PRICE	QTY 3+ PRICE	One With Any Scope Purchased From RAG
3550	±.5% ±2 digits	\$49.00	\$42.00	FREE
3525	±.25% ±2 digits	\$64.00	\$54.00	\$19.95
3510	±.1% ±2 digits	\$79.00	\$67.00	\$29.95

2 year warranty plus carrying case included!

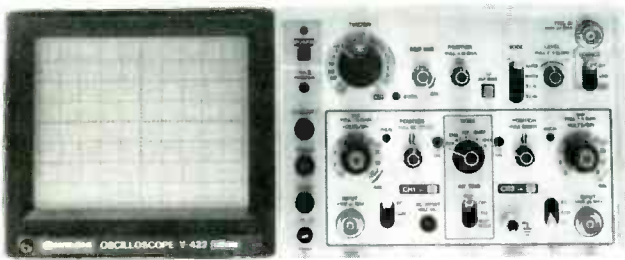

Model V-422 shown

MODEL V-222 **\$536.00**
DC to 20 MHz, 1 mV/div, Dual Trace, D.C. offset for DMM Output, Verticle Mode Trigger, 6" CRT (w/two X1/X10 probes).

MODEL V-422 **\$694.00**
DC to 40 MHz, other features same as V-222 (w/two X1/X10 probe).

MODEL V-1050F **\$1,276.00**
DC to 100 MHz, 5 mV/div, Quad Trace, Delayed Sweep, Full T.V. Triggering, alternate time base (w/two X1/X10 probes).

MODEL V-212 **\$461.00**
DC to 20 MHz, 1 mV/div, Dual Trace, Features 6" Rectangular CRT (w/two X10 probes).

MODEL V-650 **\$956.00**
DC to 60 MHz, 1 mV/div, Triple Trace, Delayed Sweep, Full T.V. Triggering, variable trigger hold-off (w/two X1/X10 probes).

NEW! 3 year warranty parts and labor on above scopes!
RAG Electronics is a factory authorized Hitachi repair center.

CIRCLE 126 ON FREE INFORMATION CARD

CALL US TOLL FREE
1-800-732-3457
IN CALIFORNIA TOLL FREE
1-800-272-4225

<ul style="list-style-type: none"> ■ Master Charge ■ VISA ■ COD ■ Money Order ■ Check 		<p>ADD FOR SHIPPING AND INSURANCE</p> <table style="width: 100%; border-collapse: collapse;"> <tr> <td>\$0 to \$250.00</td> <td style="text-align: right;">\$4.50</td> </tr> <tr> <td>\$251.00 to \$600.00</td> <td style="text-align: right;">\$6.50</td> </tr> <tr> <td>\$501.00 to \$750.00</td> <td style="text-align: right;">\$8.50</td> </tr> <tr> <td>\$751.00 to \$1000.</td> <td style="text-align: right;">\$12.50</td> </tr> <tr> <td>over \$1000.00</td> <td style="text-align: right;">\$15.00</td> </tr> </table>	\$0 to \$250.00	\$4.50	\$251.00 to \$600.00	\$6.50	\$501.00 to \$750.00	\$8.50	\$751.00 to \$1000.	\$12.50	over \$1000.00	\$15.00
\$0 to \$250.00	\$4.50											
\$251.00 to \$600.00	\$6.50											
\$501.00 to \$750.00	\$8.50											
\$751.00 to \$1000.	\$12.50											
over \$1000.00	\$15.00											

Prices subject to change without notice.

RAG ELECTRONICS, INC. / 21418 Parthenia Street / Canoga Park, CA91304 / 1-818-998-6500

WHAT'S NEWS

Talking computers seen for American banks

"Five years ago, few banks were using voice systems. In another decade—and certainly by the end of the century—the reverse will be true." That statement was made to a regional meeting of the National Association of Bank Women by Alan E. Zohott, a regional sales manager for Votrax of Troy, MI.

Among the reasons he cited were advances in microcomputer and data-communications technology, the increasing number of services offered by banks, and the hotly competitive atmosphere in banking.

Increasing postal rates will also cause greater numbers of customers to pick up their phones to pay bills, transfer money, and to check on the status of their accounts, he stated. Voice systems will be there to answer them.

But voice systems will not replace people at banks, said Zohott. "Banking is a service industry, and person-to-person dealings will always be important. But voice technology enhances the capabilities of bank personnel by working around the clock if necessary, never calling in sick, or having a car break down."

Central control unit operates everything

People definitely have a fondness for controlled devices. But with separate control units for each of the entertainment devices in a household, managing the controllers themselves can become a nuisance. A new control—which General Electric calls Control Central—is an attempt to simplify matters. The new programmable control can handle up to four in-



GE CONTROL CENTRAL programmable remote system

frared-controlled products, including TV's, video players, compact discs, cable converters, or stereo amplifiers, regardless of brand or model.

Most audio/video devices are controlled by a series of infrared pulses, combined in patterns similar to those of Morse code. When placed "head to head" with a component's original remote control, the new Control Central's computer learns the infrared codes that control that component's functions.

Control Central also has a memory bank and a liquid-crystal display that shows the functions that have been programmed into the computer's memory.

The new control unit is expected to list at \$149.95.

Record solar cells made with amorphous material

Energy Conversion Devices, Inc. (ECD), of Troy, MI, reports an unprecedented efficiency of 12.2 percent in solar cells made with proprietary amorphous (non-crystalline) materials. Stanford Ovshinsky, ECD's president, reports that ECD, in a joint venture with Standard Oil Co. of Ohio (Sohio) is already manufacturing 1-foot-wide, 1,000-foot-long continuous-strip solar cells with efficiencies in the 8 percent range.

The 8-percent efficiency cells now being made are two-layer or tandem cells. The new higher efficiency was achieved in a solar cell consisting of three extremely thin, vertically stacked sub-cells made of amorphous alloys of silicon, hydrogen, and fluorine. Each sub-cell is sensitive to a different portion of the color spectrum. The three-layer cells are said to be not only more efficient than the two-layer type, but to have a much longer operating life.

The new cells are being produced by Sovonics Solar Systems, a partnership of ECD and Sohio.

First 20,000-gate array marketed by Honeywell

A 20,000-gate CMOS (Complementary Metal-Oxide Semiconductor) gate array will shortly be put on the market as a result of a licensing agreement between Honeywell and ETA Systems, Inc. of St. Paul, MN. The array, the HC20,000, was developed by ETA Systems for its ETA-10 supercomputer planned for delivery in 1986.

The HC20,000 integrates 18,000 gates. The remaining 2,000 gates are part of a unique feature, the Built-in Evaluation and Self-Test (B.E.S.T.). B.E.S.T. allows the IC to generate its own test patterns and test itself at full-system clock rates, to sample the state of all I/O pins, force output pins to a known state, and shift test data on or off the HC20,000.

"With 400-picosecond internal NAND delays, the HC20,000 is the fastest high-density gate array in the world," says a Honeywell spokesman. "The internal gate delays are specified to be under 1.2 ns at 25°C, with a fanout of 3, and 5 mm of wiring attached." **R-E**

Superior performance now runs in the family.



Introducing the 8842A digital multimeter.

Choices. Choices.

Should you choose the powerful Fluke 8840A? Or the new, advanced 8842A?

Depending on the level of performance you need, consider this:

Enhanced capabilities for new applications.

The new 8842A is so technologically superior, it can outperform DMMs costing twice as much. Its capabilities include 0.003% 1-year basic accuracy and 100 nV resolution for dc voltage measurements. And it incorporates exclusive new thin film resistors* for a two-year calibration cycle.

The widely-accepted 8840A on the other hand, offers value unmatched by any other

DMM in its class. Like the 8842A, it's simple to operate. It gives you long-term reliability. And it delivers high productivity with a low overall cost of ownership.

Choose either model for under \$1,000.

The 8840A starts at \$760, the 8842A at \$995. With inexpensive IEEE-488 and true RMS AC options available for both models.

Which one is right for you? The choice may not be easy.

But at least now, it's a family decision.



**Call toll-free 1-800-44-FLUKE
(1-800-443-5853) Ask for extension 119.**

Talk to our sales engineers about the

8840A and the new 8842A. Take advantage of our **no-risk 15-day trial period.**

FROM THE WORLD LEADER IN DIGITAL MULTIMETERS.

FLUKE 8840A	FLUKE 8842A
0.005% basic dc accuracy (1 Yr.)	0.003% basic dc accuracy (1 Yr.)
0.16% basic ac accuracy (1 Yr.)	0.08% basic ac accuracy (1 Yr.)
0.013% basic ohms accuracy (1 Yr.)	0.008% basic ohms accuracy (1 Yr.)
Resolution to 1µV dc, 10µA dc, 1mΩ	Resolution to 100nV dc, 1µA dc, 100µΩ
One-year specifications and warranty	Two-year specifications and warranty
8840A \$760	8842A \$995
8840A-05 IEEE-488 Interface \$150	8842A-05 IEEE-488 Interface \$150
8840A-09 TRMS AC option \$185	8842A-09 TRMS AC option \$250



* Patent pending
IN THE U.S. AND NON-EUROPEAN COUNTRIES: John Fluke Mfg. Co., Inc., P.O. Box 50990, M/S 250C, Everett, WA 98206, Sales: (206) 356-5400, Other: (206) 347-6100.
EUROPEAN HEADQUARTERS: Fluke (Holland) B.V., P.O. Box 2289, 5800 CG Eindhoven, The Netherlands, (040) 458045, TLX 51846.
© Copyright 1985 John Fluke Mfg. Co., Inc. All rights reserved. Ad No. 2801-8842

CIRCLE 265 ON FREE INFORMATION CARD

ASK R-E

WRITE TO:

ASK R-E
Radio-Electronics
500-B Bi-County Blvd.
Farmingdale, NY 11735

MAGNETIC PHONO PREAMP

I installed a new turntable in my stereo system. My old turntable had a ceramic cartridge, but the new one has a magnetic cartridge. Can you supply me with a schematic of a suitable preamp for the magnetic cartridge?—B. F., St. Louis, MO

You can use a National LM387, as shown in Fig. 1. That IC is inexpensive (about \$2.00) and readily available. The pin numbers in parentheses are for one channel, and the pin numbers not in parentheses are for the other channel.

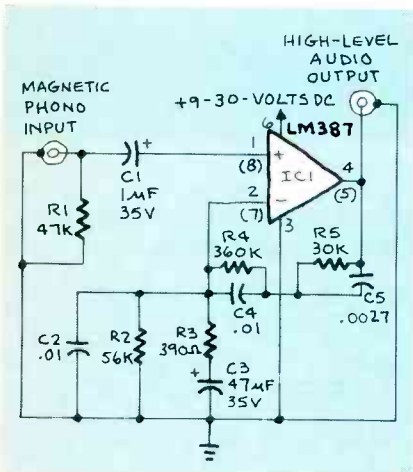

FIG. 1

The supply voltage can be anything from +9- to +30-volts DC at about 10 mA. You may be able to tap a suitable voltage from a well-filtered source in your amplifier or receiver. The output voltage swing is about $V_{CC} - 2$ volts p-p. The preamp should be able to deliver at least five volts to the AUXILIARY input of your amplifier.

R-J SPEAKER ENCLOSURE

My dad and some of his cronies claim that a speaker built into an

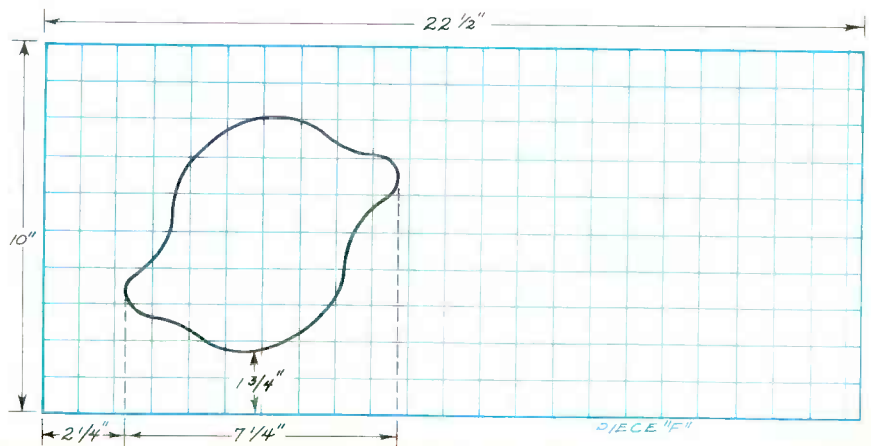
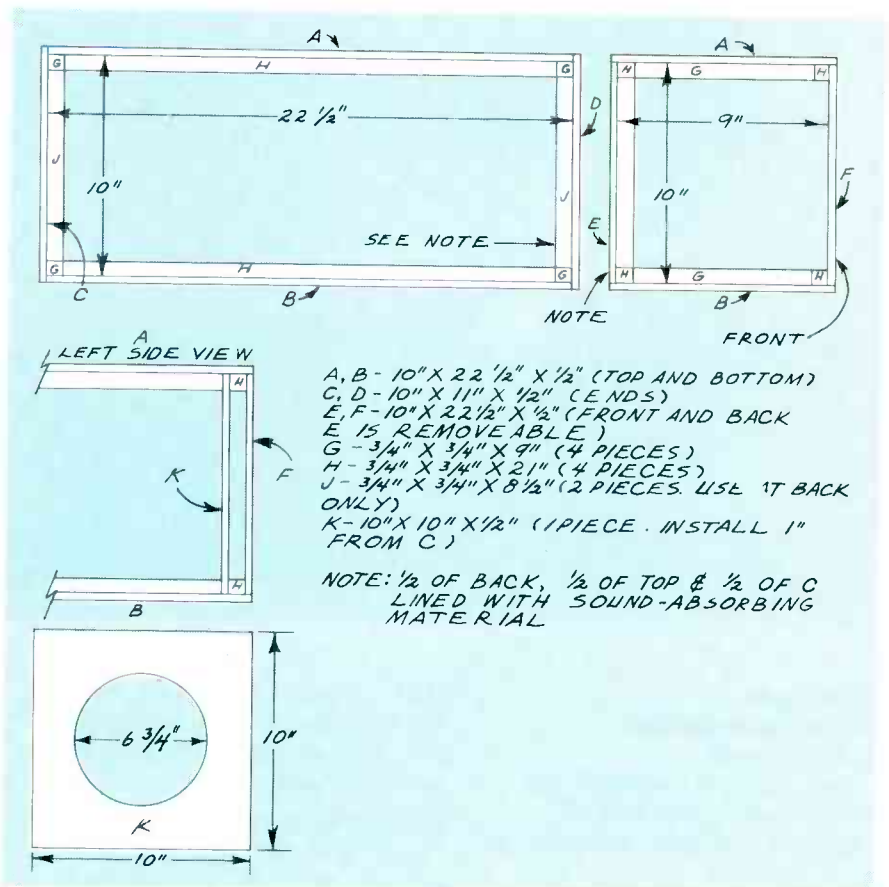

FIG. 3



SCOPE 3 1/2 DIGIT LCD MINI-METER WITH THE MAXI-SPECS

Small enough to fit in your shirt pocket

\$29.95
ONLY Model DVM-630

- 0.5% DC accuracy
- 6 Functions, 19 Ranges
 - DC Voltage, 0.1 mV to 1000 V • DC Current, 0.1 uA to 2A • Resistance, 0.1 ohm to 2 M ohm • Diode Test • Battery Test
- Measures approx. 5 x 2 3/4 x 7/8 in.
- 300 hour battery life
- Automatic zero adjust
- Low battery indication
- Test leads included

Model CC-30 Deluxe
Zippered Carrying Case \$4.50



SCOPE HAND-HELD DIGITAL CAPACITANCE and MULTIMETERS

- 0.5% DC Accuracy
- Highest Quality
- Highest Performance
- Lowest Prices



Model DCM-602
\$69.95

3 1/2 Digit Capacitance Meter
8 ranges with full scale values to 2000 uF
FEATURES • Broad test range - 1 pF to 2000 uF • LSI circuit provides high reliability and durability • Lower power consumption • Crystal time base • Protected from charged capacitors • Frequency range - 800 Hz to 8 Hz

Model DVM-634
\$48.75
7 functions, 32 ranges.
Transistor measurement included.

3 1/2 Digital Multimeters
FEATURES • DC Voltage 100 uV - 1000 V • AC Voltage 100 uV - 750 V • AC/DC Current 200 uA - 10 Amps • Resistance 20 Megohms • Capacitance (DVM 636/638) 1 pF - 20 uF • Overload Protection • Auto-decimal LCD readout • Polarity indication • 300 hour battery life with 9V transistor battery • Low battery indication

Model DVM-638
\$79.95
11 functions, 38 ranges.
Includes logic level detector, audible visual continuity, capacitance and conductance measurement.

Model DVM-636
\$62.75
8 functions, 37 ranges.
Capacitance measurement included.

ASK FOR FREE CATALOG.
Money orders, checks accepted. C.O.D.'s require 25% deposit.

Fordham

260 Motor Parkway, Hauppauge, NY 11788



Toll Free
800-645-9518
In NY State 800-832-1446

Service & Shipping Charge Schedule Continental U.S.A.		
FOR ORDERS		ADD
\$25-\$100		\$4.50
\$101-\$250		\$6.00
\$251-500		\$8.00
\$501-750		\$10.50
\$751-1000		\$12.50
\$1,001-1500		\$16.50
\$1,501-2000		\$20.00
\$2,001 and Up		\$25.00

enclosure called the *R-J* is one of the best bookshelf speakers they ever heard. Was the *R-J* really as good as they claim, or have their ears been dulled by *Father Time*? If it is as good as they say, I'd like to build a couple for the stereo in the Senior Citizen's Club.—H. O. M., Philadelphia, PA

The mere mention of the *R-J* speaker system brings back fond memories of hi-fi in the early 1950's. It was a popular system designed by Frank Robbins and William Josephs (hence the *R-J*). The *R-J* speaker system compared favorably with much larger bass-reflex enclosures, but it lacked the "boominess" of the latter. It held its own until it was gradually replaced by the *AR* and similar acoustic-suspension systems. The *R-J* design is unique because sound that emanates from the rear of the speaker emerges through a port formed by a space between the speaker mounting board and the front panel.

Plans for an eight-inch speaker enclosure are presented in Fig. 2 and Fig. 3. The front-panel open-

ing resembles a mis-shaped lemon. The major axis is about 60 degrees from the vertical, and the minor axis is about 65 degrees from the horizontal. You can build a replica of that panel by scaling the drawing up on paper with 1/2-inch squares.

Use a dense-grade of plywood or particle board for all pieces, and use glue and screws on all mating surfaces except the back (E) and the speaker board (K). Those parts are removable so that you can experiment with different speakers. Pieces of acoustically-absorbent material measuring 5 x 10 inches are centered on the back and the top, and a 5-inch square is centered on one end—either C or D.

**GOT A QUESTION?
ASK R-E!**

We welcome your questions in any area of electronics. Send them to *Ask R-E*, **Radio-Electronics**, 500-B Bi-County Boulevard, Farmingdale, NY 11735. We regret that we cannot answer your questions individually, but those of widest interest to our readers will be published.

You can use Ozite, Kimsul, Celotex, or any similar polystyrene or fiberglass insulating material.

For best results, use an 8-inch speaker with a free-air resonance of 63 Hz or lower. For high compliance, its suspension should be "soft."

ELECTRIC LOCKS

I enjoyed the item on electronic locks in "State of Solid State" in the January, 1985 issue of *Radio-Electronics*. I want to install electronic locks on some of the doors in my home. Where can I purchase the necessary hardware?—D. J. M., Salt Lake City, UT

Electric locks are used when entry is to be controlled from a remote point. You'll find them used to control entry to apartment buildings and public rest-rooms. The strike plate, mortised into the door jamb, is made so that the lock's latch-bolt is released when a low-voltage solenoid is energized. Most locksmiths can supply electric locks or tell you where to order them. **R-E**

PICK YOUR WICK.

Chemtronics manufactures desoldering wicks in two wire constructions: **Chem-Wik** for general purpose desoldering with maximum solder holding capacity and **Chem-Wik Lite**, faster acting for critical heat sensitive components. As electronic equipment becomes smaller, more complex, more demanding, Chemtronics family of pure copper desoldering wicks will meet your needs with a choice of performance characteristics for virtually every desoldering application.

Send for free literature today.

 **Chemtronics**
681 Old Willets Path
Hauppauge, NY 11788
800-645-5244
In NY 516-582-3322
Telex 968567



CIRCLE 54 ON FREE INFORMATION CARD

Call us **FREE 1-800-626-6343**
or write for **FREE** Flyer.

COPPER ELECTRONICS

4200 PRODUCE ROAD - LOUISVILLE, KENTUCKY 40218



Model 30700 wireless home video transmission system that accepts all low audio-video signal inputs from your VCR, video camera or satellite receiver and converts them to the VIF television band channel 2-6 for wireless relay to the other televisions in your home.

Retail \$119.95 **59.95**

MIDLAND
Model 76-300
AM - BASE STATION CB.



Retail \$149.95 **\$79.95**

AV-261
Permanent Mount
• 1/2" hole mount

26.95

AV-261M
Magnet Mount

29.95

AV-261T No-Hole
Trunk Mount

26.95



BEARCAT 20/20



Retail \$299.95
\$199.95

Aircraft, marine and public service—all within pushbutton reach.



uniden

Bearcat

3070

269.95

Retail \$399.95 **269.95**

Limited Quantities

THE LOWEST PRICES IN THE COUNTRY

We have a national factory warranty service on many brands, and we service All CB, Amateur, and Commercial Equipment.

CIRCLE 283 ON FREE INFORMATION CARD

**United States
Instrument Rentals, Inc.**



A U.S. Leasing Company

2988 Campus Drive
San Mateo, CA 94403

Call for Special Prices and
Free Catalog
800-824-2873



Hitachi Denshi America, Ltd.

Beckman Industrial™



SCOPES

Iwatsu

- All 14 models in stock
- 2-3 year warranties
- 20-250 MHz

Model 5702—\$ 535
5705—\$ 899
5710—\$1245
5711—\$1695
7506—\$ 749

Hitachi

- All 20 models in stock
- 2-3 year warranties
- 20-100 MHz

Model 1050—\$1299
509—\$1199
VC 6041—\$5499
422—\$ 690
1100—\$1999
650—\$ 930
V209—\$ 725
1070—\$1595
1100A—\$2490



Hitachi V-222

SALE \$535
List \$715

Hitachi V-222

Portable Dual Trace Scope

- DC-20 MHz
- 3-Way Power Supply
- Lightweight
- High Sensitivity and Fast Sweep Timer

DIGITAL MULTIMETERS

Beckman

- All 300, HD, and circuitmate series
- All accessories in stock

HD100—\$169 320—\$179
HD110—\$189 330—\$219
HD130—\$239 350—\$229
HD140—\$259 360—\$289
300—\$120 4410—\$239
310—\$145

Fluke

- Autorange • Analog display
- Touchhold function
- 0.3% accuracy • Heavy duty

Model 73—\$ 79 8010A—\$279
75—\$ 99 8012A—\$359
21—\$ 99 8020B—\$199
23—\$145 8022B—\$154
25—\$229 8024B—\$249
27—\$259 8050A—\$389

SALE \$114
List \$139

Fluke 77

Analog/Digital Multimeter



POWER SOURCES

POWER DESIGNS

- Low and high voltage power sources
- 1-5 year warranties

2020B—\$750	TW5005W—\$595
2K20—\$695	TW6050A—\$880
4050—\$660	TW347—\$695
6150—\$725	TP340—\$750
	TP343A—\$795

**Used Test Equipment, too!—Over 3,000 Models Available at
Huge Discounts with Warranties!**

- Quantity Discounts Available
- Dealers Welcome
- Freight and Tax extra
- Immediate Availability of Equipment

Call

800-824-2873

Include work address and phone #
for Free Catalog.

VIDEO NEWS



DAVID LACHENBRUCH
CONTRIBUTING EDITOR

● **Electronic Snapshots.** Eastman Kodak this year will test several electronic still-imaging products on the home market. A "video floppy" disc recorder-player will be placed in selected homes. That system uses a standardized 2-inch magnetic disk to record 50 TV fields from any television set or other video source. A wireless remote control is used to trigger the recording. A



companion product is a video-image printer that can make prints from any video field, using instant color film. It will be priced at \$700. Three Kodak processing labs will test film-to-disc transfer service, to put images from 35mm color negative film onto video floppies for playback on the TV screen through the recorder-player. The video floppy is a standardized electronic still-photo format, adopted by an industry-wide committee in Japan. A similar film-to-disc transfer service is already being offered by Fuji Photo in Japan. No consumer-priced electronic still camera is in sight, and Kodak officials forecast that it's about 10 years off.

● **Look Mom, No Tube!** Toshiba has demonstrated the largest color LCD screen yet—a 10-inch model that Toshiba says it will use for an eight-color graphics terminal in about two years, and in a TV set in three. The screen, which is backlit by three fluorescent tubes, is about five inches thick. Toshiba said it consumes one-fifth the power of a picture tube, has one-tenth the thickness, but costs four times as much. Resolution of the current display is 640 by 480, for a total of 307,200 pixels. The LCD is of the active matrix type with an amorphous thin-film transistor at each pixel, each functioning as a

switch to control and enhance the picture. The LCD is formed on a large glass substrate by photolithography and etching techniques. The display, as demonstrated in Japan, had brightness of more than 300 candelas—nearly that of a home color set—with a contrast ratio of 10 to one. Toshiba said that the practical size limitation for a display of this type is about 12 inches diagonally.

● **Changing of the Guard.** Two long-time consumer electronics lines are undergoing major changes. General Electric, one of the first manufacturers of television receivers in the United States—and the world—and a long-time leader in television technology, is departing from TV-set manufacture. Beset by tough competition and diminishing profits, GE has decided to have its color TV sets made by Matsushita Electric Industrial Company, manufacturer of Panasonic and Quasar sets, starting next August. The GE brand name will continue to appear on those sets.

Meanwhile, H. H. Scott Company, one of the American pioneers of high fidelity, has been acquired by Emerson Radio Corporation, and the brand name will be used for a high-end line of stereo components.

Scott filed under bankruptcy proceedings in 1972 and was acquired by its Belgian licensee. Incidentally, Emerson Radio has no corporate relationship to the old Emerson Radio, which was a pioneer in both radio and television; the name was acquired several years ago from National Union Electric, which took over the original Emerson Radio.

● **Video Vignettes.** Some 58 percent of all color-TV sets sold in the United States in 1984 had built-in cable-channel tuning, according to the Electronic Industries Association.

● The 27-inch picture tubes are here—three different types, in fact. RCA's deluxe tube is called the SP (for "square planar"), and it has a flat face. Zenith's tube has square corners, but normal spherical curvature of the faceplate. Sony's is a *Trinitron* with square corners and a somewhat flattened cylindrical faceplate.

R-E

CALL TOLL FREE

CALIFORNIA 800-772-1519
OTHER STATES 800-854-1519

IN SAN DIEGO CALL
619-560-9676

FREE CATALOG!



PROBE MASTER

YOUR SINGLE SOURCE FOR PROBES AND ACCESSORIES

**HIGH PERFORMANCE MINIATURE SCOPE PROBES
60 MHz TO 250 MHz**

\$30 TO \$55

ACTUAL SIZE

REPLACEMENT PROBES & TEST LEADS FOR FLUKE, TEKTRONIX, H.P. & OTHERS

OTHER PRODUCTS

- TEST LEADS
- TERMINATIONS
- ATTENUATORS
- BNC CABLES
- BNC ADAPTERS
- RUGGED AND RELIABLE
- REPLACEABLE TIP & GROUND LEAD
- ADJUSTABLE LF & HF RESPONSE
- COMPENSATION FOR MOST SCOPES

READOUT ACTUATOR (RA) OPTION



SWITCHES READOUT ON TEKTRONIX 465, 475, 485 & 7000 SERIES SCOPES. (FOR 10x probes only.)



STANDARD BNC

REPLACEABLE TIP

CHARACTERISTICS

MODEL	ATTENUATION	CABLE TERMINATION	BANDWIDTH (MHz)	RISE TIME (NS)	LOADING CAP. (PF)	*RES. (M-OHM)	DC MAX	PRICE
-------	-------------	-------------------	-----------------	----------------	-------------------	---------------	--------	-------

FIXED ATTENUATION

2903	1X	STD	25	11	40	1	600V	\$25.00
2960	10X	STD	60	5.8	16	10	500V	\$30.00
2960 RA	10X	RA	60	5.8	16	10	500V	\$40.00
2904	10X	STD	100	3.5	17	10	600V	\$35.00
2904 RA	10X	RA	100	3.5	17	10	600V	\$45.00
2905	10X	STD	250	1.5	17	10	600V	\$45.00
2905 RA	10X	RA	250	1.5	17	10	600V	\$55.00
2906	100X	STD	70	5.0	6	100	1.2KV	\$55.00

SWITCHED

2901	10X, 1X, GND	STD	10X/1X 100/5	3.5/70	17/100	10/1	600V	\$39.00
2902	10X, 1X, GND	STD	250/5	1.5/70	17/100	10/1	600V	\$49.00
1064	Engineers Accessory Kit							\$12.00

The Probe Master 2900 series oscilloscope probes combine the characteristics of high performance, a rd fast rise time pulse response, with a slender design to meet the needs of today's micro electronics. The miniature tip is ideal for accessing high density boards and hard to reach test points. By locating the high and low frequency compensation circuits in the BNC end of the cable, the design of the probe has become light weight and slender for easy handling.

Other features of the 2900 series probes include a replaceable probe tip, replaceable ground lead and a Readout Actuator option (RA).

The Readout Actuator option (permanently attached) is available on the 10x fixed attenuation probes only. This option provides the necessary resistor circuit to change the range factor on the model 465, 475, 485 and 7000 series Tektronix scopes.

The Standard Accessories included with each probe are the sprung hook, trimmer tool, BNC adapter, tip insulator, IC tip cover, spare probe tip, 6" ground lead, and a handy storage pouch. The Engineers Accessory Kit (\$12.00 option) includes a wire wrap adapter tip, wire wrap adapter ground lead, alligator tip, micro sprung hook, and a 12" ground lead.

**IMMEDIATE DELIVERY
CALL FOR NEAREST DISTRIBUTOR**



4898 RONSON CT.
SAN DIEGO, CA 92111

LETTERS



LETTERS
 RADIO-ELECTRONICS
 500-B BI-COUNTY BOULEVARD
 FARMINGDALE, NY 11735

WIRELESS VIDEO-CAMERA LINKS AND FCC REGULATIONS

This letter is in regard to the use and marketing of illegal wireless video transmitters. The article in your February issue, "Build This Wireless Video-Camera Link" falls into that category.

While those transmitters have several advertised uses, the two most common are transmission of video programming throughout the home without the need for coaxial cable, and wireless transmission of video from a camera to a VCR. The sale, marketing, or use

of those low-power video transmitters is illegal under Federal Laws and Regulations, despite claims to the contrary by some distributors and manufacturers. None of the devices are "FCC Approved" or "Comply with FCC Regulations" as is sometimes stated.

Use of those illegal devices constitutes unlicensed operation and subjects the user to severe penalties. Accepting advertising for those devices, or publishing articles on how to construct them, fosters use and perhaps entices

your readers to unknowingly violate the law. We are currently initiating legal action against all known manufacturers and distributors of wireless video transmitters; however, we hope that in the future you will refrain from accepting advertising or publishing articles that aid and abet violation of Federal laws.

DENNIS P. CARLTON
 Engineer-in-Charge
 Federal Communications
 Commission
 Field Operations Bureau
 Denver, CO

continued on page 20

CABLE TV SPECIAL!

General Instrument/Jerrold Cordless Cable TV Converter MODEL DRZ-450 (66 CHANNELS)



NEW SPECIAL!

• With Automatic Fine Tuning

\$69.95

ANY QUANTITY

TEKNIKA WIRELESS REMOTE CONTROL TV TUNER CABLE CONVERTER



SPECIAL!
 WITH VOLUME CONTROL
 140 CHANNEL
\$139.95

RG-59/U 75 OHM Co-Axial Cable
 Copper Braided Shield
 Bare copper conductor
 Braided wire copper shield
 White or Black
\$44.99/1000 ft.

CONNECTORS

F-59
 separated ferrule



6c/1000 LOT
11c/100 LOT

F-59ALM
 with attached 1/2" grip ring



7c/1000 LOT
12c/100 LOT

F 56 AVAILABLE UPON REQUEST

MATCHING TRANSFORMER



21c/100 Lot

2 WAY-75OHM U/V SPLITTER



49c/100 LOT
89c/50 LOT
99c/EA

OMNITRON

ELECTRONICS
 770 Amsterdam Ave., New York, NY 10025

Write for FREE 136 page Catalog

SHIPPING CHARGES

For Orders	ADD
\$25 - 100	\$6.50
\$100 - \$500	\$8.50
\$500 - \$750	\$10.50
\$750 - and up	\$15.00

MASTER CARD • VISA

Send Purchase Order, Check, Money Order or C.O.D.

or Call Toll Free

800-223-0826

in N.Y. State (212) 865-5580

Heathkit®



Robotics technology comes to life in building HERO® 1 and teaching it movement, speech and object manipulation.



Hams! Get the latest in amateur radio technology including high-speed Packet Radio Communication.



Powerful new IBM-PC compatible Heathkit computers are yours to build easily and save with, or to buy assembled.



Build from our full line of precision test instruments and see how they can increase your troubleshooting effectiveness.



New Digital Rain Gauge records rainfall accurately and reads out inside your home in 100ths of an inch.

Your guide to everything that's new in electronics, computers and technical education. Over 400 items. Discover fascinating kits to build, enjoy and learn with, as well as assembled high tech products for home, business and hobby.

Get our famous High Tech Catalog

FREE

Heathkit®
Heath
Company

Heath Company
Dept. 020-394
Benton Harbor, Michigan 49022

MAIL COUPON TODAY and receive the latest issue of the Heathkit Catalog free of charge

Name _____

Address _____

City _____ State _____

CL-783BR2 Zip _____

NEW!

Satellite Communications Training from NRI!



Move into commercial satellite communications and home satellite TV with NRI's latest training breakthrough!

Explore Every Aspect of Satellite Transmission and Reception As You Assemble, Install, and Train With the Complete TVRO System Included in Your Course

Back in 1964, great excitement surrounded the launching of Syncom 2, the true forerunner of today's satellites. But not even the most hopeful of scientists believed that in less than 25 years, communications satellites would have such a tremendous impact on the professional and personal lives of millions of people around the globe.

Today, thanks to the rapid development of satellite technology, a call to Paris is as clear and as easy to make as a call to your next door neighbor . . . executives from multi-national corporations and even small businesses use video conferencing to "meet" without leaving their offices . . . simultaneously a billion people witness a single event (a soccer game, an inauguration, a benefit rock concert) . . . global weather maps transmitted from satellites allow meteorologists to forecast weather trends weeks

in advance . . . and scientists now explore and investigate the mysteries of outer space without leaving their labs.

And, not surprisingly, these amazing applications of satellite technology have opened up exciting new opportunities for the technician trained to install, maintain, troubleshoot and repair satellite communications equipment.

Home Satellite TV Is Just at the Start of Its Explosive Future

You've seen them in suburban backyards and alongside country farmhouses. Home satellite TV systems are springing up all across the country.

Already there are over a million TVRO (Television Receive-Only) systems in place in the U.S. alone, and experts predict that by 1990, a remarkable 60% of U.S. homes will have a satellite dish. Contributing to the field's phenomenal growth are the support of the FCC and Congress, steady improvement in product quality, the development of smaller dishes, and a growing consumer enthusiasm for satellite TV.

New Jobs, New Careers for the Trained Technician

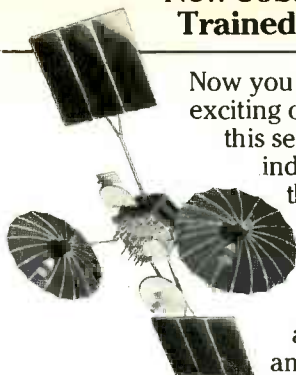

Now you can take advantage of the exciting opportunities opening up in this service- and support-intensive industry. NRI's new breakthrough training prepares you to fill the increasing need for technicians to install, adjust, and repair earth station equipment, such as dishes, antennas, receivers, and amplifiers.

As an NRI-trained technician, you can concentrate your efforts on consumer-oriented TVRO equipment. Or you can use your NRI training to build a career servicing larger commercial or military equipment used both to transmit and receive voice, data, and video signals. You'll also find opportunities in sales and system consulting, a role some expect to increase tenfold within the next five years on both the corporate and consumer levels.

NRI Brings Satellite Technology Down to Earth

Only NRI has the resources and the skills necessary to transform today's most sophisticated technology into understandable, step-by-step training.

NRI's new course in Satellite Communications gets you in on the ground floor of this booming technology. You are thoroughly trained in the necessary basic electronics, fundamental communications principles, and television transmission and operation.

Using the remarkable NRI Discovery Lab[®], you demonstrate first-hand many important points covered in your lessons. You perform critical tests and measurements with your digital multimeter. And, using your NRI Antenna Applications and Design Lab, you assemble and test various types of antennas and matching sections.

Then you concentrate on both commercial and consumer satellite earth station equipment, putting theory to practice as you assemble and install the 5' parabolic dish antenna system included in your course.

Your Home Satellite TV System Brings Theory to Life!

The Wilson TVRO system included in your course comes complete with 5' parabolic dish antenna system, low-noise amplifier (LNA), down converter, receiver, low-loss coaxial cable, and even a permanent polar mount.

By training with an actual TVRO system, you'll come to understand the function and operation of a satellite earth station—knowledge that you can apply to both consumer and commercial equipment. And once you have completed your TVRO system, you'll have access to the best television entertainment available—direct from the satellite to your home.

At-Home Training the Uniquely Successful NRI Way

It's hands-on training, at home . . . designed around the latest state-of-the-art electronic equipment you work with as part of your training. You start from scratch and "discover by doing" all the way up to the level of a fully qualified professional. You conduct key experiments . . . perform vital tests . . . install your own system . . . and you do it at the pace that suits you best.

But, most important to your success, you don't do it alone. Built into your NRI training is the enormous experience of our development specialists and instructors, whose long-proven training skills and personal guidance come to you on a one-to-one basis. They are always available for consultation and help.



Make Your Move Into the Future Today! Send for Your FREE NRI Catalog

Only NRI can train you at home for an exciting and rewarding career as a satellite communications technician. The knowledge and know-how you gain from your NRI training provide you with the soundest possible foundation for further growth with the industry. But now is the time to act. Return the post-paid card to us today. You will receive your 100-page catalog free. It's filled with all the details you'll want to know about our training methods and materials and our more than 70 years of successful

innovation in at-home, hands-on career training—the kind of experience that enables NRI to provide the most effective training possible to prepare you for today's, and tomorrow's, high-tech opportunities. (If the card is missing, write to us at the address below.)

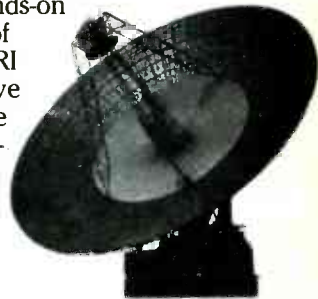

NRI SCHOOL OF ELECTRONICS

McGraw-Hill Continuing Education Center
3939 Wisconsin Avenue, NW
Washington, DC 20016

We'll give you tomorrow.



LETTERS

continued from page 14

Our readers should be aware that the manufacturers of such devices are not the only ones that are subject to penalty. Consumers using such equipment are also subject to a \$10,000 fine, a jail term, and seizure of their equipment. Although the Commission has received petitions and requests to legalize low-powered video trans-

mitters, it has denied them because of concern about possible interference to licensed TV broadcast stations. If, despite that warning, you continue to use the transmitter, you should reduce its output power to lessen the chance of unintentional interference.—
Editor

PULSE GENERATOR ERRORS

I am building the pulse generator described in "Versatile Pulse Generator," *Radio-Electronics*,

November 1985. I have found the following errors in Fig. 2, on page 59:

- J4 is not shown.
- R16 is across J7 in the figure, but the text says J6.
- IC4 (4050) is shown as 14 pin; it is 16 pin.
- D3 should be labeled D1.

Except for the second item, correction is obvious. What worries me: are there more errors? I shall be waiting impatiently for comment in an upcoming issue.

SIGMUND S. KAHN
Brooklyn, NY

The schematic is correct, so R16 should go across J7. By the way, we too are impatient sometimes—that's what causes some errors. Thanks for your eagle-eyed corrections.—*Editor*

THE BRAZILIAN CONNECTION

I read your article about the remote controller (*Radio-Electronics*, October, 1985) and I would like to know how can I get data sheets on those IC's, as well as other kinds of information, including typical applications, etc. And how can I get sample IC's to experiment with?

The problem is that I'm from Brazil, and it's very difficult to find those parts and that kind of information in our electronics marketplace.

Thanks for the help—and congratulations for the high quality of your magazine.

PAULO ROBERTO M.M. OLIVEIRA
Avenida Angelica, 1399 apto 112
Cep 01227, Sao Paulo, Brazil

You should be able to obtain those IC's from the supplier mentioned in the article by remitting U.S. funds. For data sheets, you should contact Motorola Semiconductor Products Inc. 3501 Ed Bluestein Blvd., Austin, TX 78721.—*Editor*

OWNER'S MANUAL NEEDED

I purchased a tuner-video analyzer, model 10WX from Mercury Tuner (103 East 165 Street, Bronx, NY). I lost the manual, and the company has since gone out of business. I will pay \$5.00 for a copy.

WILFREDO RAMIREZ
305 W 72 Street
New York, NY 10023

R-E

ELENCO PRODUCTS AT DISCOUNT PRICES!

DIGITAL LCR METER

Measures Inductance, Capacitance and Resistance

At Last! An LCR meter that everyone can afford. Now you can measure coils, transformers, chokes from 1 μ H to 200 H, capacitors from .1 pfd to 200 mfd and resistors from .01 ohms to 20 megohms. All in one handheld instrument.

SPECIFICATIONS

Capacitors	
Range	• 200 pF, 2 nF, 20 nF, 200 nF, 2 μ F, 20 μ F, 200 μ F
Resolution	• 0.1 pF, 1 pF, 10 pF, 100 pF, 1 nF, 10 nF, 100 nF
Accuracy	• < 0.5 μ F \pm (2% + 1 dgt) > 0.5 μ F \pm (3% + 1 dgt)
Inductance	
Range	• 2 mH, 20 mH, 200 mH, 2 H, 20 H, 200 H
Resolution	• 1 μ H, 10 μ H, 100 μ H, 1 mH, 10 mH, 100 mH
Accuracy	• \leq 0.5 H \pm (3% + 1 dgt) > 0.5 H \pm (5% + 1 dgt)
Resistance	
Range	• 20, 200, 2 k, 20 k, 200 k, 2 M, 20 M Ω
Resolution	• 0.1, .1, 1, 10, 100, 1 k, 10 k Ω
Accuracy	• < 1 M Ω \pm 1% + 1 dgt

NEW
MODEL
LC-1800
\$148



GF-8016 Function Generator with Freq. Counter

\$229

- Sine, Square, Triangle, Pulse, Ramp, .2 to 2 MHz
- Frequency .1 thru 10 MHz



GF 8015 without Freq. Meter \$169

35 MHz Dual Trace Oscilloscope

\$550 Model MO-1252

- Delayed Trigger
- 2 Year Guarantee
- 2 Probes Included



MO-1251 20 MHz Dual Trace \$385⁰⁰

AC Current Meter

\$98 Model ST-1000

- Reads 20, 200, 1000 A
- DC & AC Volts, Resistance
- 3 1/2 LCD Digits
- Deluxe Carry Case



True RMS 4 1/2 Digital Multimeter

\$135 Model M-7000

- .05% DC Accuracy
- .1% on Resistance
- 5% True RMS AC
- 5% Freq. Counter 1-200 kHz
- Deluxe Case Included



AC Current Meter

\$48 Model ST-310

- Reads 300 Amps (5 ranges)
- DC & AC Volts, Resistance
- Case & Leads Included



3 1/2 Digital Multimeter

\$25 Model M-1600

- 1% DC Accuracy
- 1% on Resistance
- 1.5% AC Accuracy
- Reads 10 DC Amps



C&S SALES, 8744 W. North Ter.
Niles, IL 60648 • (312) 459-9040



15 DAY MONEY BACK GUARANTEE

2 Year Limited Guarantee! Add 5% for Postage (*10 Max.), Ill. Res., 7% Tax

TO ORDER TOLL FREE 1-800-292-7711

CIRCLE 282 ON FREE INFORMATION CARD



ELECTRONICS BOOK CLUB

Keep In Step With the Future . . . Become a Part of the Fascinating World of Technology!

- High-Tech How-To
- Space Age Projects
- Digital Electronics
- Artificial Intelligence
- Robotics
- Computers
- Telecommunications
- And much more!

Select 5 Books for Only \$2⁹⁵

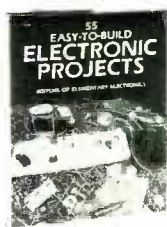

1999 List \$21.95



1693 List \$21.95



800P List \$19.95 (paper)

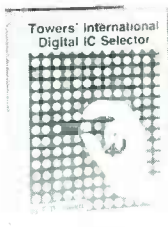

1616 List \$19.95

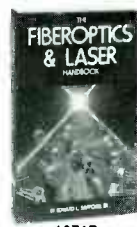

1671P List \$16.95 (paper)



1984 List \$14.95



1665P List \$15.95 (paper)



1875P List \$14.95 (paper)



1160 List \$14.95



1183 List \$16.95

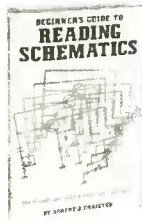

1536 List \$14.95



1245P List \$16.95 (paper)

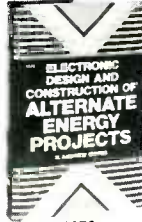

1672 List \$18.95



1625 List \$21.95



1108 List \$16.95



1594 List \$18.95

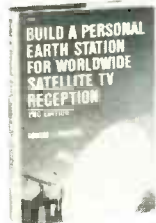

1909 List \$21.95



1553 List \$15.95



1604P List \$15.95 (paper)



1793 List \$14.95



1465 List \$16.95

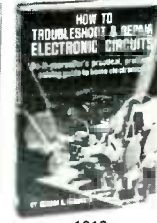

1218 List \$18.95



1899 List \$24.95



1199 List \$21.95



1663 List \$24.95



1211P List \$12.95 (paper)



1013 List \$12.95



1277 List \$21.95

FREE Handy, Pocket-Sized Resistor and Inductor Color Code Calculator

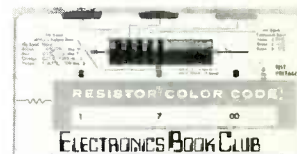

FREE When You Join Now

7 very good reasons to join the Electronics Book Club

- **Big Savings.** Save 20% to 75% on books sure to increase your electronics know-how
- **No-Risk Guarantee.** All books returnable within 10 days without obligation
- **Club News Bulletins.** All about current selections—mains, alternates, extras—plus bonus offers. Comes 13 times a year with hundreds of up-to-the-minute titles to pick from
- **Automatic Order.** Do nothing, and the Main selection will be shipped automatically! But . . . if you want an Alternate selection—or no books at all—we'll follow the instructions you give on the reply form provided with every News Bulletin
- **Bonus Books.** Immediately get Dividend Certificates with every book purchased and qualify for big discounts of 60% to 80%
- **Extra Bonuses.** Take advantage of added-value promotions, plus special discounts
- **Exceptional Quality.** All books are first-rate publisher's editions selected by our Editorial Board and filled with useful up-to-the-minute information

ELECTRONICS BOOK CLUB

P.O. Box 10,
Blue Ridge Summit, PA 17214

Please accept my membership in The Electronics Book Club and send the 5 volumes circled below, plus my FREE Resistor and Inductor Color Code Calculator, billing me only \$2.95 plus shipping and handling charges. If not satisfied, I may return the books within ten days without obligation and have my membership canceled. I agree to purchase 4 or more books at regular Club Price (plus shipping/handling) during the next 12 months, and may resign any time thereafter.

800P 1013 1108 1160 1183 1199 1211P 1218 1245P
1277 1465 1536 1553 1594 1604P 1616 1625 1663 1665P
1671P 1672 1693 1793 1875P 1899 1909 1984 1999

Name _____
Address _____
City _____
State _____ Zip _____ Phone _____

Valid for new members only. Foreign applicants will receive ordering instructions. Canada must remit in U.S. currency. This order subject to acceptance by the Electronics Book Club.

RE-386

EQUIPMENT REPORTS

G-E's Control Central Programmable Remote Control

Replace all of your infrared handheld remotes with a single transmitter!



CIRCLE 5 ON FREE INFORMATION CARD

REMOTE-CONTROL CAPABILITY WAS once thought to be the ultimate in convenience. But having too much of it can be a problem: It's

almost impossible to pick the correct handheld remote unit on the first try! But now there's a solution to remote-control clutter: *Control*

Central from G-E (General Electric Company Consumer Electronics Business Operations, Electronics Park, Syracuse, NY 13221).

Control Central is a programmable remote system that can take the place of four infrared handheld remotes. The actual programming is very easy: You simply place the *Control Central* head-to-head with an infrared transmitter and press the matching keys on each unit. Although we left out a few steps, it's really that easy. But before we fill in the programming details, let's take a look at some other features of this innovative product.

Control Central uses a Mitsubishi 50747 microprocessor (which is upward compatible with the 6502), 4K of battery-backed-up CMOS RAM, and 8K of ROM. It is designed to operate with most infrared remote-control systems. *Control Central* looks the part of a remote transmitter, except that it's slightly larger than most (about 1 x 3 x 8 inches) and it has an LCD readout. It weighs in at just over one-half pound.

The remote control has four source inputs, called TV, VCR, CABLE, and AUX, and its keypad is labelled to correspond to most common functions from those devices. For example, the keypad's primary keys include POWER, CHANNEL UP/DOWN, VOLUME UP/DOWN, and MUTE keys. The VCR section of the keypad includes such keys as RECORD, VCR/TV, PLAY, STOP, PAUSE, FAST-FORWARD, REWIND, and forward and backward SCAN. The secondary-key section is used for additional commands, and for direct channel entry or other numerical entries.

Along with the functions we mentioned, there are a host of other less-common key functions



"In Just A Few Days, I'll Show You How To Do

REAL MATH

$$\int_a^b f \quad \sum_{n=1}^x a_n \quad \frac{df}{dx}$$

On Your Calculator!"

lim $\frac{df}{dx}$ $\frac{df}{dx}$ •Quick. •Guaranteed. •Easy. •Fun, Too!

INTRIGUED BY CALCULATORS? Then you can step up your math skills fast! Use my new method in guidebook form. It's called *CALCULATOR CALCULUS*. This space-travel spinoff is sure-fire, so it has a simple guarantee — just return it for an immediate refund if you are not astounded at the problems you're solving with it!

But the point is — you won't want to send it back. For this is the easiest, fastest shortcut ever! The day you receive your copy in the mail you'll want to put it to work. It's that exciting and helpful.

My name is Dr. George McCarty. I teach math at the University of California. I wrote this guidebook to cut through the confusion. I guide you with examples you follow step-by-step on your calculator — you do simple exercises — then you solve practical problems with real precision!

POWER METHODS. Need to evaluate functions, areas, volumes — solve equations — use curves, trig, polar coordinates — find limits for sequences and series? It's all here!

If you're in the biological, social or physical sciences, you'll be doing Bessel functions, carbon dating, Gompertz growth curves, half-life, future value, marginal costs, motion, cooling, probability, pressure — and plenty more (even differential equations).

Important numerical techniques? Those algorithms are here, too: rational and Padé approximation, bracketing, continued fractions, Euler's method, Heun's method, iteration functions, Newton's method, predictor-corrector, successive substitutions, Simpson's method and synthetic division.

LOOK AT WHAT USERS SAY: Samuel C. McCluney, Jr., of Philadelphia writes:

"*CALCULATOR CALCULUS IS GREAT!* For ten years I have been trying to get the theory of calculus through my head, using home study courses. It was not until I had your book that it became clear what the calculus was all about. With your book and a calculator the whole idea becomes clear in a moment, and is a MOST REFRESHING EXPERIENCE. I program some of the iterative problems you suggest and it always

GIVES ME A THRILL to see it start out with a wild guess and then approach the limit and stop.

Professor John A. Ball of Harvard College (author of the book *Algorithms for RPN Calculators*) writes: "I wish I had had as good a calculus course."

Professor H. I. Freedman of the U. of Alberta, writing in *Soc. Ind. Appl. Math. Review*, states:

"There can be no question as to the usefulness of this book... lots of exercises... very clearly written and makes for easy reading."

Tektronix Engineer Bill Templeton says "*CALCULATOR CALCULUS* is the best most clearly written book I have seen for improving your math skills."

I WANT YOU TO DO THIS. Get my complete kit, with a TI-35 calculator, plus its 200 p. Student Math Book, AND the guidebook, ALL for \$44.95 (for shipping to USA add \$2, or \$5 by AIR; Foreign \$5, or \$10 AIR; \$2.70 tax in CA). Order Stock No. 7-11

If you already have a scientific calculator, you can invest in *CALCULATOR CALCULUS* for only U.S. \$19.95 (to USA or foreign; add \$1 for shipping, or \$4 by AIR; \$1.20 tax in CA). Order Stock No. 6-11

As pennywise Ben Franklin said, "An investment in knowledge pays the best dividends." GET STARTED NOW — Tax deductible for professionals.

MONEY-BACK GUARANTEE! Send for it today. Be sure to give me your complete mailing address with your check or money order. If you want to charge it (Visa or MC), tell me your card no. and exp. date. Prompt shipment guaranteed.

Thank you!

George McCarty

EduCALC Publications
27951 Cabot Road, Laguna Niguel, CA 92677
For fast service, phone MC or VISA orders
TOLL FREE to (800) 633-2252, Ext. 340.

**FORDHAM WILL BEAT
ANY ADVERTISED**

**B&K
LEADER
HITACHI
AW SPERRY
NON-LINEAR
BBC**

**OSCILLOSCOPE PRICE
by \$25⁰⁰**

No ifs, ands or buts.

Copyright © Fordham 1985

Must be a currently advertised price.
This offer may be withdrawn at any time without prior notice.

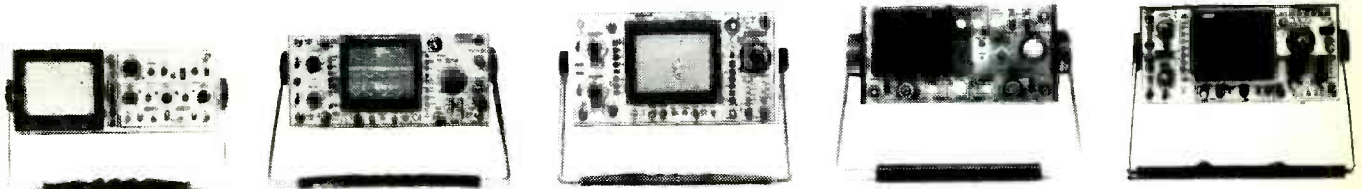

ASK FOR FREE CATALOG.
Money orders, checks accepted. C.O.D.'s require 25% deposit.



Fordham Toll Free **800-645-9518**

260 Motor Parkway, Hauppauge, NY 11788

In NY State 800-832-1446

**Service & Shipping Charge Schedule
Continental U.S.A.**

FOR ORDERS	ADD
\$25-\$100	\$4.50
\$101-\$250	\$6.00
\$251-500	\$8.00
\$501-750	\$10.50
\$751-1,000	\$12.50
\$1,001-1,500	\$16.50
\$1,501-2,000	\$20.00
\$2,001 and Up	\$25.00

WHAT'S NEW?

Blimey, mates! You'll be amazed at the great new products & values we have for you!



You Can Get Stereo Satellite TV At An UNHEARD-OF Price! **ONLY \$199**

State of the art circuitry and advanced technical standards give you stereo satellite reception with maximum performance. This 70 MHz single conversion receiver features SAW IF Filter, Auto TV Thru-Mode on Standby/Power Off, and Base-Band Output for Descramblers. Cat D-6332

ROCKDALE STEREO SATELLITE RECEIVER

Move Your Dish Without Leaving the House!



\$249 Cat D-6335

SATELLITE POSITIONER & ACTUATOR

Raining? don't get soaked just because you need to move your satellite dish. With this Actuator (a motor-controlled arm that attaches to dish & mount) and Positioner (the remote control unit that sits under your receiver or TV), you can position your dish in total comfort. This unit is designed to suit most dishes. Install it yourself and save!

COMPLETE SATELLITE TV SYSTEMS FROM DICK SMITH!
BUY THE SYSTEM AND SAVE

We carry a complete line of components to assemble custom satellite TV systems, or you can take advantage of the special values available with our system packages!

ROCKDALE STEREO SYSTEM

Includes Stereo Receiver, 6" Dish, Low Noise Amplifier, Down Converter, Feed Horn, Cable - Everything you need!

Save \$186
\$799.00

AUSTRALIS 1 SYSTEM

Includes Receiver Kit, 6" Dish, Low Noise Amplifier, Down Converter, Feed Horn, Cable - Everything you need!

Save \$186
\$699.00

Cat K-6316

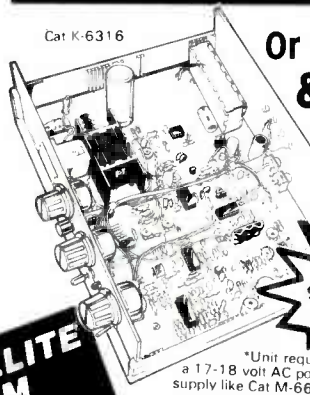

Or Build Your Own Receiver & SAVE A FORTUNE!

"The performance rivals commercial receivers costing hundreds of dollars more. The ease of assembly &... field proven circuitry is fantastic, the quality... better than expensive commercial units."

Richard Maddox, author of *Troubleshooting & Repairing Satellite TV Systems*

You can put this kit together in just hours! Why wait any longer to enjoy the world of satellite television?

ONLY *
\$99.95
PLUS \$4 SHIPPING

*Unit requires a 17-18 volt AC power supply like Cat M-6672.

AUSTRALIS 1 SATELLITE RECEIVER KIT

AS FEATURED IN DEC & JAN RADIO ELECTRONICS



\$18.95

This is a comprehensive guide for both home TVRO owners & professional service technicians. It covers installation, testing, servicing, alignment, & information not available in other handbooks.

Cat B-1845

VHF/UHF MASTHEAD AMP

This high gain amp (VHF 25 dB, UHF 20dB) boosts TV & signals even in fringe areas. Its high input capability resists overload on strong signals, while a built-in FM trap cuts interference. Includes UL-listed AC adaptor.

Cat L-4200

IN-LINE VHF AMP

This 10dB video amp has a bandwidth of 50-450 MHz & output capability of 30 dBmV. Noise figure is 4 dB & impedance is 75 ohms.



Cat L-4201

DIP METER

Frequency Range: 1.5-250 MHz in 6 plug-in coils
Modulation: Approximately 2 KHz sine wave
Crystal Oscillator: 1-15 MHz
Power Supply: 9V DC
Semiconductors: 2 transistors & 1 diode

Cat Q-1335

\$59.95

A Whole New Range of **"OK"** BRAND WIRE WRAP TOOLS Call for Special Catalog!

Hand-Held Convenience!

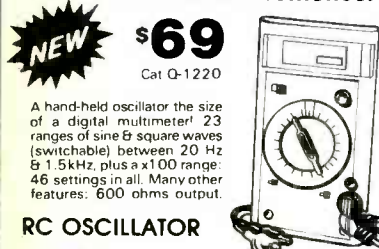

\$69 Cat Q-1220

A hand-held oscillator the size of a digital multimeter! 23 ranges of sine & square waves (switchable) between 20 Hz & 1.5kHz, plus a x100 range; 46 settings in all. Many other features: 600 ohms output.

RC OSCILLATOR

Your Board Missing a Track? No Worries!

Get CIRCUIT-FIX KIT

Make circuit repairs & changes fast & simple! Kit includes spring-loaded clamp & guide, collet knife & blade, 154 asst. copper donuts, 32 sq. in. of foil & instructions.

Copper Foil Donut Refill Cat H-5902 \$4.00
1 oz. Adhesive Copper Foil Cat H-5903 \$4.00

Make Your Own PCB'S Directly from Magazine Art!

\$34.95 All necessary materials are in this kit! 5" x 6" steel print frame, film & processing pack, yellow filter, 4 oz. etch resist, 16 oz. developer, blank copper boards, dry concentrated etch and 1:1 resist patterns & tapes, instructions.

PHOTO-ETCH PRINTED CIRCUIT KIT

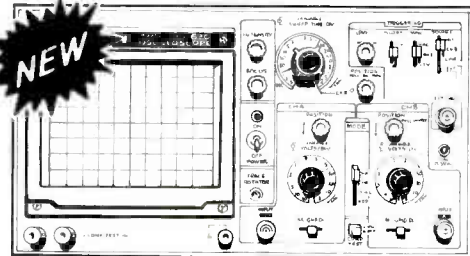

As always, Dick Smith brings you more for less! Our new model dual-trace 20 MHz oscilloscope is packed with features. The high brightness CRT assures easy readability, and a specially designed circuit for component testing allows you to determine component status in or out the circuit board! Other features include: wide bandwidth & high sensitivity, very low power consumption, high sensitivity X-Y mode, 2 axis (intensity modulation) panel electrical trace rotator, & regulated power supply circuit for accuracy. And the best feature of all: our new low price!

20 MHz DUAL-TRACE OSCILLOSCOPE

\$399 Cat O-1240

DUO-TEMP SOLDERING IRON

It's two tools in one! Its normal tip idling temperature of 680°F is ideal for delicate printed circuits. Press a button and the power is doubled! The push-button also allows faster heating or "pulsing" to match heat output to the heat absorption of the task at hand!

\$22.95 Cat T-1830

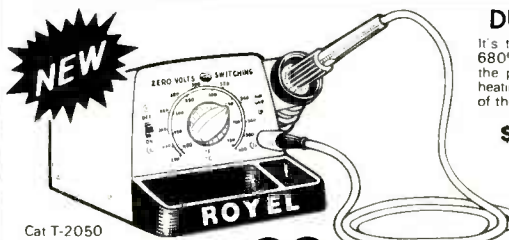

Cat T-2050

\$99

The ideal professional iron! It's ultra-light weight, so you can use it comfortably for long periods. Superior design ensures that the temperature at the tip will be precisely the one selected. This is a lasting iron for the production line or workshop.

PROFESSIONAL SOLDERING STATION

CIRCLE 95 ON FREE INFORMATION CARD



Educational & Safe **ONLY \$6.95**



DICK SMITH'S FUNWAY 3 INTO ELECTRONICS
Volume 3
INTEGRATED CIRCUITS

\$6.95

Cat B-2610

Learn About Integrated Circuits with Dick Smith's

FUNWAY 3 INTO ELECTRONICS

Volume 3

Dick Smith's FUNWAY INTO ELECTRONICS series is packed with projects designed to teach electronics while entertaining inquiring minds & busy hands. Volume 3 is for those who have worked their way through volumes 1 & 2 for the advanced hobbyist. It contains 10 fascinating projects based on integrated circuits. We also offer matching kits like the two below to make building these projects even easier!

Learn Components in Funway V.1 Cat B-2600 \$4.95
Learn Soldering in Funway V.2 Cat B-2605 \$6.95

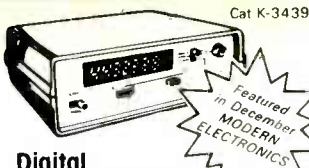

Cat K-3439

Featured in December MODERN ELECTRONICS

Digital FREQUENCY COUNTER KIT \$89.95

Superb design uses latest IC technology. Low component count makes it very reliable and easy to build. Measures frequency to 500 MHz (with optional prescaler) and period both with a 7 digit resolution. Supplied with the exclusive Dick Smith simplified step-by-step instructions and a quality pre-punched and silk screened front panel and case.



Cat K-6312

Compare with Ready-made Units!

\$44.95

As seen in QST Oct '85

UHF SWR POWER METER KIT

Directivity >20db
Insertion Loss >0.3db
Freq Response (narrow band) 400-520 MHz
Max Power 100 watts

MOSFET AMP KIT PROFESSIONAL SERIES

Cat K-3516

POWER OUTPUT One Channel 184 W RMS
Both Channels 104 W RMS 95 W RMS

HARMONIC DISTORTION Less than 0.2% for all powers up to 100 W into 8 ohm loads
Less than 0.3% for all powers up to 180 W into 4 ohm loads

Complete kit includes Case & Front Panel **\$299**

MINI AMP KIT * \$14.95

Cat K-2667

Want an amplifier for your walkie stereo or radio? Don't be tied to phones: use this project and listen in comfort! Or you can build this into a mini PA Amplifier.

★ Requires FUNWAY hook Volume 3 (Cat B-2610) for complete construction details

MINI SYNTH KIT * \$19.95

Cat K-2669

It's a real beauty, this one: a real 'live' musical synthesiser - and it's live because it uses YOU as the note generator! you get an amazing range of control over the sound.

★ Requires FUNWAY hook Volume 3 (Cat B-2610) for complete construction details

PRESCALER KIT Cat K-3432

Increase the range of your K-3439 Frequency Counter to a more professional range of operation: 10-500MHz

\$22.50

KITS

Cat K-3252

Protect your 2nd most valuable investment with the Dick Smith Deluxe Car Alarm

Door & ignition alarms are no longer enough to save your car from professional thieves! Get the features of costly commercial alarms in this easy-to-build, inexpensive kit!

- 2 delayed & 6 instant outputs
- 10 sec. delayed entry & exit times
- Aux. battery provision • Siren output
- Flashing dash lamp internal key-operated on/off, etc.

\$59.95

DESIGNER BOARDS

Now designing is so simple! No soldering, no mess - and each board comes with a pad of layout paper!

- Cat P-4614 3" x 2.4" x 3" \$4.95
- Cat P-4615 7" x 2.7" x 3" \$9.95
- Cat P-4616 8" x 6" x 8" \$19.95
- Cat P-4617 8" x 9.75" x 8" \$29.95

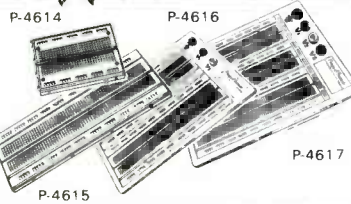

RE-CHARGEABLE BATTERIES

Now Available! 2 New Sizes of "No-Leak" GEL CELLS

- 6V @ 1-2 Ah **\$6.95** Cat S-3310
- 12V @ 9 Ah **\$34.95** Cat S-3325
- 12V 1.2 Ah **\$7.95** Cat S-3315
- 12V 3 Ah **\$13.95** Cat S-3320

Ask about our GELL CELL CHARGERS!

Please state charger required when ordering.

LISA KEYBOARD CLOSEOUT- You Reap the Benefit!

Cat J-0055

Apple's loss is your gain: OVERTY keyboard with numeric keypad & more! There's no warranty, but at this price you can afford 3 or 4 spares!

were \$19.95 **\$9.95**

POWER SUPPLIES

3-6-9-12 VDC @ 1 amp

\$14.95

Invaluable around the home or workshop. It will give a maximum of 1 amp at 3.6, 9 and 12 volts DC. Simply plugs into 117 VAC power socket-DC connections. Ideal for use with alarm systems, intercoms, etc.

HEAVY-DUTY SOLID-STATE 13.8V/5A Peak

\$19.95

Regulated DC Power Supply. 13.8 VDC, 3/4 Amp. For home, lab, service bench, CB stereo and auto radios, this is an extremely versatile unit! You'll wonder how you managed without it! Input is 117 VAC 60Hz 100W, and the output is fully regulated low ripple up to 5 amps surge. The unit is fuse and double-short circuit protected with on/off switch and pilot light.

CONNECT WITH SAVINGS

'D'TYPE COMPUTER CONNECTORS

PLUGS (SOLDER TAIL)

- 9 Pin were \$1.25 Cat P-2684 10 up 75c **79c**
- 15 Pin were \$1.60 Cat P-2687 10 up 85c **89c**
- 25 Pin were \$1.95 Cat P-2690 10 up \$1.05 **\$1.15**

SOCKETS (SOLDER TAIL)

- 9 Pin were \$1.75 Cat P-2685 10 up 85c **89c**
- 15 Pin were \$2.20 Cat P-2688 10 up 99c **\$1.09**
- 25 Pin were \$2.60 Cat P-2691 10 up \$1.35 **\$1.45**

BACKSHELLS

- For P-2684, P-2685 were 90c Cat P-2686 10 up 57c **63c**
- For P-2687, P-2688 were \$1.00 Cat P-2689 10 up 59c **65c**
- For P-2690, P-2691 were \$1.25 Cat P-2692 10 up 60c **65c**

NOW OPEN IN L.A.

CALL WRITE, OR VISIT OUR RETAIL CENTERS!

STORES AT:
BERKELEY: 2474 Shattuck Ave. (415)486-0755
REDWOOD CITY: 390 Conventon Way (415)368-8844
SAN JOSE: 4980 Stevens Creek Blvd (408)241-2266
WESTWOOD: 1830 Westwood Blvd. (213)474-0626
HEAD OFFICE: 390 Conventon Way, Redwood City, CA 94063

ORDERS ONLY: CALL TOLL FREE 1-800-332-5373 (Mon-Fri, 6am-6pm PACIFIC TIME)
IN CALIFORNIA: 1-415-368-1066

WHERE THE ELECTRONIC ENTHUSIAST IS # 1!

DICK SMITH ELECTRONICS

INCORPORATED IN THE STATE OF CALIFORNIA

MAIL ORDERS
P.O. Box 8021 Redwood City CA 94063
14 DAY MONEY-BACK GUARANTEE
SHIPPING & HANDLING:

We ship UPS Ground unless otherwise requested. Add 5% of order total (\$1.50 minimum) for shipping (20% outside the U.S.A. - \$4.00 minimum). There is an additional \$1.00 handling fee for California residents please add sales tax.



FREE CATALOG

132 pages of products & data! Includes Bonus Coupons worth \$2 redeemable with your first order. Send only \$1 for postage & handling.

NAME ADDRESS CITY STATE ZIP

CIRCLE 95 ON FREE INFORMATION CARD

Power to the Product!

Low cost B&K-PRECISION DC power supplies with high cost features

NEW



Model 1630 (3 amp) \$225
Model 1610 (1 amp) \$150

Now you can have the power you need, wherever you need it, at a surprisingly low cost.

These new B&K-PRECISION power sources each give you control up to 30 volts DC with fully adjustable current limiting. Other features include:

- Excellent regulation and low-ripple characteristics
- Dual meters monitor voltage and current simultaneously
- Two current ranges
- Fine and coarse voltage controls
- Isolated output
- Protected against reverse polarity external voltages
- Two identical supplies can be connected in series or parallel
- Can be used as a constant voltage or constant current source

Compare prices, features and performance, and you'll agree that the 1610 and 1630 power supplies are revolutionary.

Available for immediate delivery at your local B&K-PRECISION distributor. For additional information or the name of your local distributor contact B&K-PRECISION.

BK PRECISION
DYNASCAN
CORPORATION

6460 West Cortland Street
Chicago, Illinois 60635 • 312/889-9087

International Sales, 6460 W. Cortland St., Chicago, IL 60635
Canadian Sales: Atlas Electronics, Ontario
South and Central American Sales,
Empire Exporters, Plainville, NY 11803

included. But it's important to remember that a key function (or a source function) is not limited to its label. For example, if you want the CHANNEL UP key to actually turn up the volume, then you're free to program the *Control Central* to do it. By the same token, if a function that your device requires is not available on the keypad, you're free to designate any key to it. It all depends on how you program the unit.

Programming Control Central

Teaching *Control Central* the infrared commands that your equipment needs could hardly be easier. But we should note that it might not even be necessary because the unit comes pre-programmed with codes to operate G-E equipment, and those codes work with several other brands as well. So before you start teaching *Control Central*, you should try its pre-programmed commands.

If you do have to program *Control Central*, the first step is to use a ball-point pen (or similar object) to slide the USE/LEARN switch to the LEARN position. The words "LEARN MODE" flash in the display window three times, followed by "1 SELECT SOURCE 2 PRESS ENTER." Following the displayed instructions, you press the SOURCE key to display the component name (TV VCR CABLE or AUX) that you want *Control Central* to learn, and then press the ENTER key. The display then flashes "READY PRESS MATCHING KEYS," which tells you that you should place *Control Central* head-to-head with the existing remote transmitter, and press the appropriate keys on each. When *Control Central* thinks it has learned the function, its displays prompts you to "RELEASE" the keys. But to make sure it has things right, it will ask you to "DO AGAIN", at which time you again press the matching keys. If everything works as planned, you will be greeted by the words "FUNCTION LEARNED."

There are a host of "display window functions" that are accessed by pressing the FUNCTION key after a source has been selected. Although they're too numerous to list in full here, they include functions such as TINT, BRIGHT CONTRAST, SHARP, BALANCE, TREBLE, BASE

G-E		Control Central												
OVERALL PRICE														
EASE OF USE														
INSTRUCTION MANUAL														
PRICE/VALUE														
		1	2	3	4	5	6	7	8	9	10			
		Poor		Fair			Good			Excellent				

and stereo-TV controls for the TV source; SLOW, SCAN, SELECT, CUE, TIMER, AND EJECT for the VCR source; and PROGRAM, RNDM ACC, SEEK INDEX, DISC, AND MEMORY for the AUX source.

It is possible to teach the *Control Central* the commands from more than one transmitter in a single source. For example, the AUX source could be programmed to learn some commands from your CD player, and some commands from your stereo receiver. You could also, perhaps, program both your VCR commands and your TV commands in a single source, so that you wouldn't have to switch sources to control both. Unfortunately, there are a few problems with doing that. First, mixing codes in one source memory uses memory inefficiently, so you run the risk of a memory overload if you mix codes. It's also important to realize that not all infrared links use the same frequency, so not all transmitters can be mixed on a single source.

If you have more than four devices to control, then the ability to mix codes on a single source is very important, because it can expand the number of devices that *Control Central* can operate. If that feature is important to you, we suggest that you try to mix the appropriate codes before you buy *Control Central*.

Control Central has a suggested price of \$149. Whether it's worth it depends on how often you've had to search through several remotes for the correct one. We expect that many readers of this magazine would benefit from the convenience that *Control Central* offers.

R-E

continued on page 28

NEW!!
1986
ITEMS!*

- Quality Components
- Over 700 Items Available From Our 500 Authorized JIM-PAK Distributors
- Competitive Prices
- For information call (415) 595-5936 Telex #176043
- Distributors Welcome

COMPUTER ACCESSORIES



JE860

- Part No. JE232CM**
RS232 Interface (For Commodore VIC-20 & C-64)
- Part No. JE860**
16K RAM Card (For Apple II & II+)
- Part No. JE864**
80-Column/64K RAM (For Apple IIe)
- Part No. JE875**
Disk Drive Controller (For Apple II, II+ & IIe)
- Part No. M1008K**
RAM Expansion (For TRS-80 Model 100)
- Part No. KHP4007**
Switching Power Supply (For Apple II, II+, IIe)

DATA BOOKS

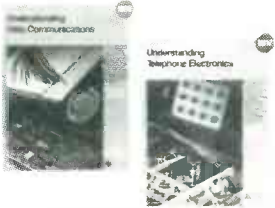

30024/30025

- Part No. 30013**
Zilog Microprocessor Data Book
- Part No. 30021**
National CMOS Data Book
- Part No. 30024**
TI Understanding Data Communications
- Part No. 30025**
TI Understanding Telephone Communications
- Part No. 30029**
Motorola MC6800 Data Book
- Part No. 205775**
Intel MCS 80/85 Family User's Manual

INTEGRATED CIRCUITS

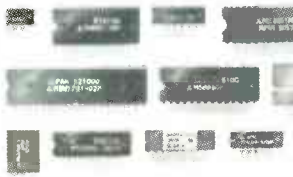

MICROPROCESSORS

- Part No. 2816A**
16K (E)EPROM (350ns)
- Part No. 6802**
MPU — 8-Bit with Clock and RAM
- Part No. 8279-5**
Prog. Keyboard/Display Interface
- Part No. 8748**
MPU — HMOS EPROM
- Part No. 27256**
256K EPROM (250ns)
- Part No. 41256-15**
256K Dynamic RAM (150ns)

TOOLS



PLIER-5

- Part No. Cutter-5**
Diagonal/Side Cutter (4 3/4 inch)
- Part No. Hemo-1**
Hemostat (5 inch Straight Tip)
- Part No. Plier-5**
Five Piece Plier Set (5 inch)
- Part No. Probe-40**
4 Piece Probe Set (5 1/2 to 6 1/2 inch)
- Part No. Tweezer-2**
Tweezer (Dumont 4 1/2 inch Curved)

*PARTIAL LISTING

JIM-PAK AUTHORIZED DISTRIBUTORS

<p>ALABAMA Birmingham, Huntsville, Montgomery, Opelika, American Electronic Supply, J.L.S. Electronics, W&W Electronics, Handy's Elect. Center, Southern Electronic Corp.</p> <p>ALASKA Anchorage, Homer, Electric Supply Center, A-COM of Alaska</p> <p>ARIZONA Scottsdale, Sierra Vista, Tucson, Yuma, Electronic Parts Outlet, B&S Electronics, Electronic City, Yuma Electronics</p> <p>CALIFORNIA Anaheim, Altamadero, Berkeley, Carpinteria, Chico, Chula Vista, Concord, Costa Mesa, Cowana, Cucamonga, Dublin, Eureka, Fontana, Fresno, Fresno, Glennville, Goleta, Half Moon Bay, Harbor City, Hawaiian Gardens, Hollywood, Inglewood, Lancaster, Lompoc, Modesto, Monterey, Morro Bay, National City, North Edwards, Oakland, Oceanside, Orange, Palo Alto, Redding, Sacramento, Sacramento, San Carlos, San Diego, San Francisco, San Jose, San Luis Obispo, San Luis Obispo, San Rafael, Santa Cruz, Santa Cruz, Santa Maria, Santa Rosa, Santa Rosa, Sunnyvale, Torrance, Torrance, Vallejo, Ventura, Westminster, Whittier, Willow, Al Lasher's Electronics, Electronic Resources, Payless Wholesale, The Electronics Warehouse, Lion Electronics, Pacific/Valley Electronics, Mar-Vac Electronics, G&H/AMCO Elect. Supply, Abletronics, Pacific/Valley Electronics, Redwood Electronics, Fontana Electronics, Sparky Electronics, Whincamm Electronics, Eagle Electronics, Bill's Stereo, Strawflower Elec. Radio Shack, Bull's Electronics, Carlson Electronics, Pacific Radio Exchange, Radioland/Inglewood Elect. Consumer Electronics, L&H Electronic Emporium, Inland Electronics, Coast Electronics, Zackit, Willy's Electronics, Econotronics, Pacific/Valley Electronics, Electronic Center, California Electronics, Zack Electronics, Radio Mart, MarVac's Calif. Radio Electronics, Zack/Sacramento, J&H Outlet, Radio Shack/Mira Mesa, Zack Electronics, Schall Electronics, United Radio and TV, Coast Electronics, Mid State Electronics, Electronics Plus, Santa Cruz Electronics, Electronic Parts Supermart, Ardo Electronics, Pacific/Valley Electronics, Sunnyvale Electronics, Signal Electronics, Torrance Electronics, Zackit, JANVAC Electronics, JK Electronics, Whittier Electronics, COBGO Electronics</p> <p>COLORADO Boulder, Colorado Springs, Colorado Springs, Denver, Lakewood, Hapco, Calco Digital Equipment, Centennial Electronics, Fiestell's Microelectronics, O.H. Crump Co.</p>	<p>CONNECTICUT Trom Trown USA, Lake Charles, Melaine, Shreveport, Shreveport, Computer Products, Micro Products, Wholesale Electronics</p> <p>FLORIDA Daytona Beach, Fort Walton Beach, Gainesville, Hialeah, Oakland Park, Orlando, Pensacola, Plantation, C&S Electronics, Palm Electronics, Skopier Electronics, Heathkit Electronic Center, Dharamdas Sons, Lafayette Radio, C&S Electronics, Pensacola Electronics, Heathkit Electronic Center</p> <p>GEORGIA Atlanta, Atlanta, Dalton, Stone Mountain, A.C.M. Computer Mart, Heathkit Electronic Center, A.C.M. Computer Mart, Coleman's Electronics</p> <p>HAWAII Honolulu, Kaliua, Kona, Pearl City, A.I.'s Electronics, Industrial Electronics, Integrated Circuit Supply, Mar Ma Electronics, Heathkit Electronic Center</p> <p>IDAHO Kimbali Electronics, R.J.M. Electronics, Kimbali Electronics</p> <p>ILLINOIS Berwyn, Carbondale, Downers Grove, Groveland, Mount Prospect, Niles, Peoria, Quincy, South Holland, B.B.&W. Electronics, Pick's Electronics, Suburban Electronics, Merit Electronics, Tri-State Elect., Joseph Electronic, Warren Radio Co., Show Me, Union Electronic Dist.</p> <p>INDIANA Lakeland Electronics, Stansler Radio, Chesterton Electronics, Hutch & Son, Calumet Electronics, Electronic Dept., Warren Radio Co., P.E.I./Genesis, Industrial Electronics, Von's Electronics</p> <p>IOWA Ames, Clinton, Davenport, Des Moines, Iowa City, Electronic Supply, Inc., Union Supply Co., Radio Trade Supply, Union Supply Co.</p> <p>KANSAS Overland Park, Salina, Wichita, Wichita, Lexington, Louisville, Louisville, Paducah, Bursten & Assoc. Electronics, Inc., Amateur Radio Equipment, Lloyd's Radio & Elec., R.S.C. Electronics</p> <p>KENTUCKY Lexington, Louisville, Louisville, Paducah, Radio Electronic Equip. Co., Heathkit Electronic Center, Peerless Electronic Equip. Co., Warren Radio Co.</p> <p>LOUISIANA Baton Rouge, Baton Rouge, Broussard, Houma, Industrial Elect. Supply, Menard Electronics, Menard Electronics, Pelican Electronics, Pelican Electronics</p>	<p>LOUISIANA (Continued) Wheatsale Radio & Equip., Pelican Electronic Supply, Industrial Electronic Supply, Southern Electronics</p> <p>MARYLAND Havco Electronics, Healthkit Electronic Center, Mark Electronics, Electronics Plus, Revaco of Maryland, The Comm Center, J&M Electronics, Revaco Electronics, Suburban Wholesalers, Baynesville Electronics</p> <p>MASSACHUSETTS Peabody, Pittsfield, Springfield, Heathkit Electronic Center, Pittsfield Radio Equipment, Sydlite Electronic Supply</p> <p>MICHIGAN Ann Arbor, Bay City, Detroit, Detroit, East Detroit, East Detroit, Fenlon, Grand Rapids, Grand Rapids, Grand Rapids, Jackson, Lansing, Lansing, Livonia, Madison Heights, Muskegon, Saginaw, Saginaw, Saint Clair Shores, Taylor, Traverse City, Westland, Wademyer Electronics, Wademyer Elect. Supply, Kinde Distributing, Electronic Parts Co., S&S Electronics, Electronic Parts Co., Heathkit Electronic Center, Tri County Electronics, Shand Electronics, Radio Parts Inc., T&W Electronics, Warren Radio, Fulton Radio Supply, Wademyer Elect. Supply, Northwest Electronics, Warren Radio, H&R Electronics, Niles Radio Supply, Ryder Distributing, Shand Electronics, Bell Electronics Co., Tel Van Electronic Supply, Traverse City Elect. Supply, The Electronic Connection</p> <p>MINNESOTA Duluth, Hopkins, Minneapolis, Moorhead, Northwest Radio of Duluth, Heathkit Electronic Center, Acme Electronics, Northwest Radio</p> <p>MISSISSIPPI Biloxi, Jackson, Pascagoula, Hooper Electronic Supply, Ellington Electronic Supply, Hooper Electronic Supply</p> <p>MISSOURI Cape Girardeau, Columbia, Kansas City, Rolla, Sedalia, Springfield, Show Me Electronics, Show Me Electronics, Show Me Electronics, Show Me Electronics, Show Me Electronics</p> <p>MONTANA Bozeman, Great Falls, Hooper Electronic Supply, Ellington Electronic Supply, Hooper Electronic Supply</p> <p>NEBRASKA Lincoln, Scott Electronic Supply, Scott Electronics</p> <p>NEVADA Las Vegas, Sparks, Century 23, Computer House</p> <p>NEW JERSEY Ocean, Trenton, Vineland, Healthkit Electronic Center, Laroza Radio, Laroza/Vineland</p>	<p>NEW JERSEY (Continued) Alamagordo, Basin Electronics</p> <p>NEW YORK Amherst, Amherst, Bathpage, Buffalo, Commack, Jamestown, Jencho, Johnson City, Kingston, Middletown, Newburgh, New York, N. White Plains, Poughkeepsie, Rensselaer, Rochester, Troy, Utica, Audio Center, Heathkit Electronic Center, Electronic No. 24 Inc., Radio Equipment Corp., Spartan Electronics, Warren Radio, Heathkit Electronic Center, Unicorn Electronics, Greylock Electronics, Greylock Electronics, Actron Audio Inc., T&H Electronics, Heathkit Electronic Center, Greylock Electronics, Electronic Stockroom, Heathkit Electronic Center, Trojan Electronic Supply, Central Electronics</p> <p>NORTH CAROLINA Greensboro, Winston-Salem, Heathkit Electronic Center, Trayer, Inc.</p> <p>NORTH DAKOTA Fargo, Fargo, Mandan, Radio & TV Equipment, S/S Electronics, John Iverson Company</p> <p>OHIO Akron, Bryan, Canton, Cleveland, Lancaster, Parma, Parma, Toledo, Toledo, Wickliffe, Youngstown, Warren Radio, Bernie's Radio, Electronic Center, Inc., Heathkit Electronic Center, Electronic Supply Co., Superior Electronics, Heathkit Electronic Center, Warren Radio, Amateur Electronic Supply, Ross Radio Co.</p> <p>OKLAHOMA Bartlesville, Lawton, Oklahoma City, Tulsa, All-State Electronics, Trice Electronics, Trice Electronics, Trice Electronics</p> <p>OREGON Beaverton, Corvallis, Portland, Norvac Electronics, Zero Dee Electronics, Portland Radio Supply</p> <p>PENNSYLVANIA Chambersburg, Drexel Hill, Erie, Frazer, McKeesport, Philadelphia, Philadelphia, Proxessville, Pittsburgh, York, Sunrise Electronic Dist., Kass Electronic Dist., Warren Radio, Heathkit Electronic Center, Barno Radio, Heathkit Electronic Center, Spectrum Electronics, Stevens Radio Shack, South Hills Electronics, Computer Center of York</p> <p>RHODE ISLAND Cranston, Pawtucket, Jabbour Electronics, Jabbour Electronics</p> <p>TENNESSEE Bristol, Chattanooga, Greenville, Knoxville, Memphis, Shield's Electronic Supply, Shield's Electronic Supply, F&L Electronics, Shield's Electronic Supply, Bluff City Electronics</p>	<p>TENNESSEE (Continued) Memphis, Nashville, Nashville, Smyrna, Warren Radio, Eddie Warners Inc., Electra Dist. Co., Deiker Electronics</p> <p>TEXAS Brownsville, Dallas, Fort Worth, Harlingen, Lubbock, McAllen, McAllen, Odessa, Richardson, Richardson, George's Electronic Mart, Heathkit Electronic Center, George's Electronic Mart, Trice Electronics, George's Electronic Mart, Valley Wide Electronics, Whitlock Instrument, Martin Wholesale Electronics, Trice Electronics</p> <p>UTAH Midvale, Ogden, Provo, Salt Lake City, Heathkit Electronic Center, Carter Supply Co., Alpine Electronic Supply, Knaball Electronics</p> <p>VERMONT Burlington, Greylock Electronics</p> <p>VIRGINIA Annandale, Arlington, Blacksburg, Bristol, Charlottesville, Hampton, Harrisburg, Lynchburg, Norfolk, Norfolk, Norfolk, Richmond, Roanoke, Vienna, Woodbridge, Arcade Electronics, Arlington Electronics, Wholesalers, Scotty's Radio & TV, Shield's Electronic Supply, Graves Electronics, Cain Electronics, Electrical Wholesalers, Electronic Service Co., Avc Electronics, Cain Electronics, Priest Electronics, Avc Electronics, Avc Electronics, Electronic Equipment Bank, Cain Electronics, E.G.E.</p> <p>WASHINGTON Bellevue, Bellingham, Cheney, Gig Harbor, Olympia, Pullman, Seattle, Seattle, Seattle, Spokane, Spokane, Tacoma, A.B.C. Communications, Cascade Electronics, Long's Electronics, Northwest Electronics, The Electronic Shop, H&B Electronics, A.B.C. Communications, Amateur Radio Supply, Electronic Supply Co., Bits, Bytes & Nibbles, Don's Stereo Center, C&G Electronics</p> <p>WEST VIRGINIA Fairmont, Morgantown, Wheeling, T.P.S. Electronics, Electro Dist. Co., industries</p> <p>WISCONSIN Kenosha, Chester Electronic Supply</p> <p>FOREIGN Canada: British Columbia/Victoria, Fort Micro Systems, Guam: Agaña, Marianas Electronics, Guatemala: Electrónica Pan Americana, Panama: Soniel S.A., Topico S.A., Puerto Rico: Hato Rey Microcomputer Store, Saudi Arabia: Jeddah, Hisham Nwailat Establishment</p>
--	--	--	--	---

Learn micro-processing with the new
MICRO-PROFESSOR 1P



Students, engineers or technicians—
upgrade your micro-processing skills
with the new Micro-Professor 1P.

The MPF-1P features:

- extensive software support
- more built-in memory
- improved keyboard
- larger display

Three tutorial guides help cover all
capabilities. The ideal training tool!
MPF-1P will deliver you into the growing
world of micro-processing. Invest now!

Plus—FREE GIFT Only **\$199.95**

□ Check this box for FREE
Z-80 Microprocessor
Programming and
Interfacing textbook when
you order within 7 days.
\$12.95 value. (Include
\$5.00 postage &
handling)

ETRONIX

Dept. RE0286
5326 9th Ave. N.E.
Seattle, WA 98105-3617

For immediate action call TOLL FREE:

1-800-426-1044

Full money back guarantee.

VISA

MasterCard

CIRCLE 111 ON FREE INFORMATION CARD

**SUPER
LONG PLAY
TAPE RECORDERS**

10 Hour Model — \$95.00*
14 Hour Model — \$159.00*

Modified Panasonic Slimline.
high quality. AC-DC
Recorders provide 5 or 7
continuous hours of quality
recording & playback on
each side of cassette for a
total of 10 or 14 hours
depending on model. Built-in
features include • Voice
level control. • Digital
counter. etc. TDK DC 180
Cassette Furnished



PHONE RECORDING ADAPTER

Records calls automatically. All Solid
state connects to your telephone
jack and tape recorder. Starts
recording when phone is lifted.
Stops when you hang up.

\$24.50*

FCC APPROVED

VOX VOICE ACTIVATED CONTROL SWITCH

Solid state. Self contained. Adjust-
able sensitivity. Voices or other
sounds automatically activate and
control recorder. Uses either re-
corder or remote mike. \$24.95*

*Add for ship & hdng. Phone Adapter & Vox \$1.50 ea.
Recorders \$4.00 ea. Cal. Res. add tax. Mail order. VISA,
MIC, COD's OK. Money Back Guarantee. Qty. disc.
avail. Dealer Inquiries invited. Free data.
AMC SALES INC. Dept. A 9335 Lubec
St., Box 928, Downey, CA
90421 (213) 869-8519

CIRCLE 108 ON FREE INFORMATION CARD

**Uniden-Bearcat 800XLT
Scanner Receiver**

*A top-of-the-line scanner
with expanded frequency
coverage.*



CIRCLE 6 ON FREE INFORMATION CARD

WITH THE GROWING USE OF THE 800-
MHz band, it was only a matter of
time before scanners capable of
covering that band made their ap-
pearance. One such scanner is the
Uniden-Bearcat 800XLT (6345 Cas-
tleway Court, Indianapolis, IN
46250). That microprocessor-con-
trolled, 40-channel unit covers
four ham bands; aircraft, military,
public safety, and federal govern-
ment frequencies, as well as the
aforementioned 800-MHz band.

Specifically, the unit covers the
following frequency bands: 30 to
50 MHz, 118 to 135.975 MHz, 136
to 144 MHz, 144 to 148 MHz, 148 to 174
MHz, 406 to 420 MHz, 420 to 450
MHz, 450 to 470 MHz, 470 to 512
MHz, and 806 to 912 MHz. The unit
offers Uniden's track-tuning fea-
ture. That feature causes the scan-
ner to tune a channel for peak
signal-strength, and then to track a
signal (in the event of drift, etc.) so
that the peak strength is main-
tained.

LED's to the front panel. Those are
used to indicate the status of a par-
ticular channel; that is whether
the unit's lockout, priority, or de-
lay functions have been selected.
On other Bearcat models, that in-
formation was presented as part of
the frequency/channel readout.
Because that caused the readout to
be cluttered, the information was
sometimes difficult to discern at a
glance. This system offers a much
clearer indication of the channel's
status. As to the channel/frequen-
cy readout, it uses a bright, easily
read, fluorescent tube display.

The keypad, like those on other
Uniden-Bearcat scanners, and un-
like those on units from many
other manufacturers, uses real
pushbuttons, rather than a plastic
membrane overlay. The keypad is
used for frequency entry, pro-
gramming the priority channel,
and selecting search, lockout, or
delay modes. It has a positive tac-
tile response. An interesting fea-
ture of the pad is the presence of a
wx key; pressing that key activates
an automatic weather-service
search mode. In that mode, the
unit scans all National Weather
Service frequencies in the area.

On the rear of the unit there is
the access hatch for the memory-
backup batteries, as well as con-
nectors for AC power, DC power
(13.8 volts), ground, and antennas.
Yes, we said antennas. On most
other scanners, including those
that offer 800-MHz coverage, a sin-
gle antenna input is all that is
provided. On the 800XLT, there is a
separate input for an 800-MHz an-
tenna. Incidentally, the unit is sup-
plied with both a stub antenna for
800-MHz, and a telescoping anten-
na for the other frequencies. Part-
ially due to an excellent receiving
location, a hilltop that is some 230
continued on page 102

Uniden-Bearcat	800XLT									
OVERALL PRICE	■	■	■	■	■	■	■	■	■	■
EASE OF USE	■	■	■	■	■	■	■	■	■	■
INSTRUCTION MANUAL	■	■	■	■	■	■	■	■	■	■
PRICE/VALUE	■	■	■	■	■	■	■	■	■	■
	1	2	3	4	5	6	7	8	9	10
	Poor		Fair		Good			Excellent		

The 800XLT

When we unpacked our unit,
one of the first things we noticed
was its strong resemblance to ear-
lier Bearcat units, such as the 220
or 350. But a closer examination
revealed some very important dif-
ferences.

One difference that is especially
significant is the addition of three

FLUKE 70

SERIES MULTIMETERS



- 77 • 0.3% Accuracy
- Manual or Autorange
 - 10A + mA Range
 - Beeper
 - "Touch-Hold" Function

Sale,
\$129⁹⁵
 75 89⁹⁵
 73 69⁹⁵

WE CARRY A FULL LINE OF FLUKE MULTI-METERS. IN STOCK NOW

SALE ENDS Mar. 31

BECKMAN'S CIRCUITMATE[®] ALL UNDER \$100

AVAILABLE NOW. . . .

\$64⁹⁵

Circuitmate DM-20—3½-digit, pocket-size multimeter; 0.8% Vdc accuracy, diode test, hFE test, conductance, 10 amps AC and DC ranges, auto-polarity auto-zero, auto-decimal

\$69⁹⁵

Circuitmate DM-40 — 3½-digit multimeter; 0.8% Vdc accuracy, diode test, auto-polarity, auto-zero, auto-decimal

\$79⁹⁵

Circuitmate DM-25—3½ digit, pocket-size multimeter; 0.5% Vac accuracy, diode test, capacitance, continuity beeper, conductance, 10 amps AC and DC ranges, auto-polarity, auto-zero, auto-decimal

\$89⁹⁵

Circuitmate DM-45 — 3½-digit multimeter; 0.5% Vdc accuracy, diode test, continuity beeper, 10 amps AC and DC ranges, auto-zero, auto-polarity, auto-decimal

BK PRECISION DYNASCAN CORPORATION

BREAKS THE PRICE BARRIER WITH THESE HIGH PERFORMANCE OSCILLOSCOPES

- 100 MHz Dual Trace/ Dual Time Base**
- 1 mV/div sensitivity
 - 23 calibrated sweeps
 - Rectangular CRT with internal graticule and scale illumination
 - Signal Delay Line

\$995

Does not include probes (\$60.00 a pair when purchased with scope)

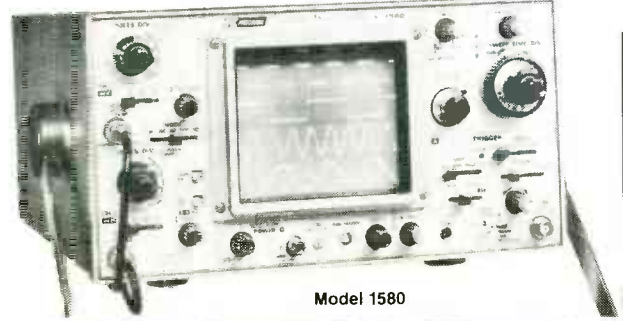

Model 1580

QUANTITIES ARE LIMITED

BK PRECISION INDUSTRIAL TRANSISTOR TESTER

\$219⁹⁵

MODEL 520B

- Now with HI/LO Drive
- Works in-circuit when others won't
- Identifies all three transistor leads
- Random lead connection
- Audibly and visually indicates GOOD transistor

BK PRECISION 100 MHz Dual Time Base SCOPE MODEL 1590

\$1395⁰⁰

PRICE DOES NOT INCLUDE PROBES

- 1mV/division sensitivity to 70 MHz
- 500 μV/division cascade sensitivity
- Four-input operation provides trigger view on 4 separate inputs
- Alternate time base operation
- Switching power supply delivers best efficiency and regulation at lowest weight

TOLL FREE HOT LINE
800-223-0474
 212-730-7030

ADVANCE ELECTRONICS

26 WEST 46th STREET, NEW YORK, N.Y. 10036

Full-featured frequency counter.

The DM850 offers more than any digital multimeter in its price class:

4½ digits. DCV accuracy is .05% + 3 digits

True RMS

Frequency counter to 200KHz

Data Hold display capability

DCV-5 ranges (.2V to 1kV)

ACV-5 ranges (.2V to 750V)

DCA/ACA-6 ranges (.2mA to 10A)

Ohms-6 ranges (200 Ohms to 20 Megohms)

Continuity beeper

Diode check

Built-in bail

Anti-skid pads

Prices: DM850 (True RMS) . . . \$219⁹⁵*

DM800 (Average RMS) . . . \$169⁹⁵*

See one now at your local Beckman Industrial distributor.

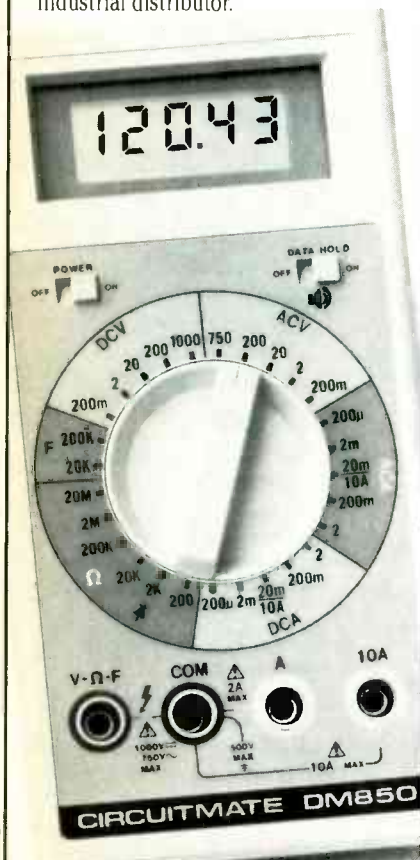

*Suggested list price (\$US) with battery, test leads and manual.

Beckman Industrial™

Beckman Industrial Corporation
A Subsidiary of Emerson Electric Company
630 Puento Street, Brea, CA 92621
(714) 671-4800

© Copyright 1985 Beckman Industrial Corporation

CIRCLE 98 ON FREE INFORMATION CARD

NEW PRODUCTS

ANTENNA DRIVE, the programmable Satscan, model 6254, features solid-state operation, without mechanical relays. It allows users to access satellites directly via pre-programmed location. For example: to move the antenna to Satcom III-R, simply press the Satcom key and the number-3 key. The antenna then moves to that position automatically.

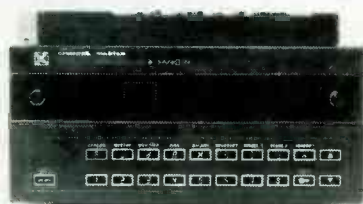

CIRCLE 21 ON FREE INFORMATION CARD

The unit's microprocessor memory also allows coded parental control. Using the lock function, access to specific satellites may be restricted, or the antenna may be locked onto a particular satellite. Outdoor components of the Satscan drive system include a heavy-duty actuator drive with low 35-volt DC operation; the unit is protected by a weatherproof, expandable jack sleeve and motor boot. Automatic shutoff prevents motor wear by restricting movement to the range of the satellite arc.

The model 6254 is priced at \$649.95.—**Channel Master**, PO Box 1416, Industrial Park Drive, Smithfield, NC 27577.

DEMODULATOR, the Quest Video Interface, is a stand-alone Channel 3 (NTSC standard) demodulator, designed specifically for the video enthusiast.

A high level of selectivity at the



CIRCLE 22 ON FREE INFORMATION CARD

input is accomplished by means of a SAW (Surface Acoustic Wave) filter. The filter is specifically designed for direct signal input at the Channel 3 frequency. It circumvents the signal deterioration that results from mixing down the input signal to an intermediate frequency for processing.

The output of the SAW filter is configured for quasi-parallel signal processing. With that system, the audio and video are separated from one another and sent to individual processing circuits. That enables the device to demodulate the audio and video signals separately, rather than deriving the audio from the negative output of the video demodulation circuit, ensuring good resolution and stability.

The principal application of the Video Interface for video enthusiasts is the conversion of pay-cable programming. The device will convert the Channel 3 output of a cable converter, or similar device, to composite video and discrete audio. Those signals can then be routed to any other device having provisions for video and audio inputs, such as VCR, video monitor, audio amplifier, or a video processor.

The Quest Video Interface sells for \$139.95.—**Quest Custom Video**, 22931 Edmonds Way, Edmonds, WA 98020.

R-E

Build Circuits Faster and Easier With Our \$20 Solderless Breadboard

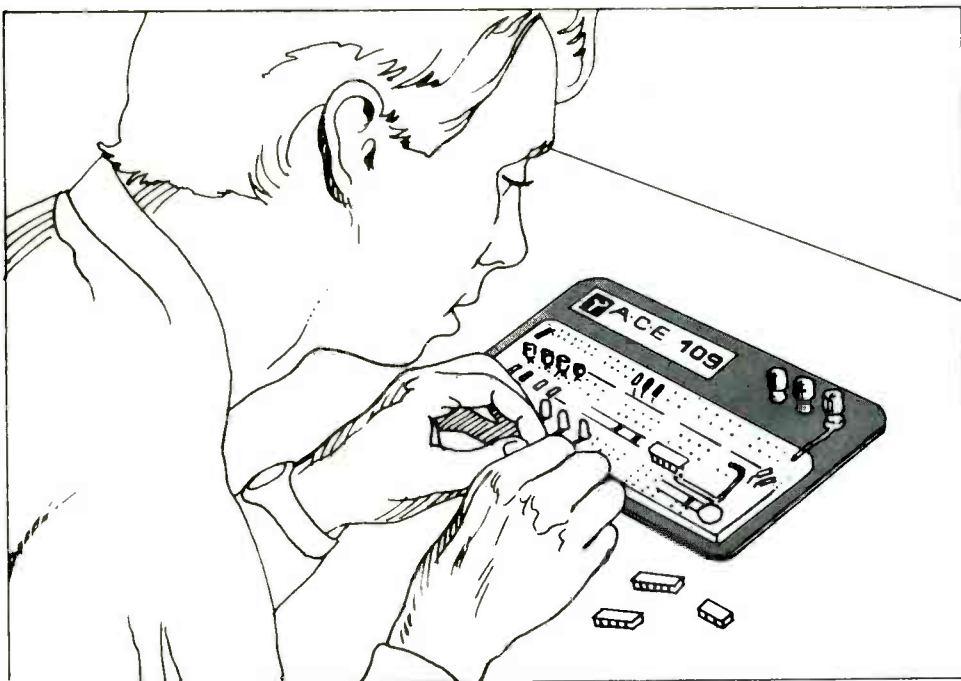

...and do even
more with our
\$40 breadboard

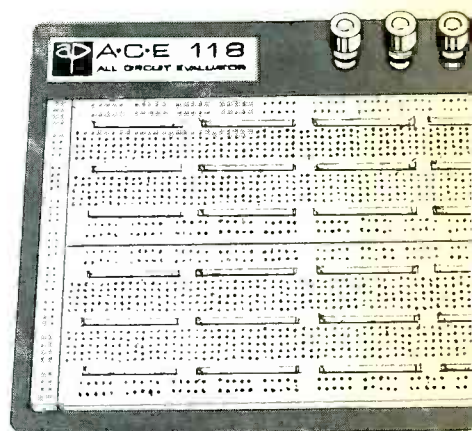

Introducing the plug-in world of AP Product's versatile, low cost breadboards.

Now you can design, build and test prototype circuits just like the professionals...and make changes in seconds. No messy soldering or desoldering. No more twisted leads or damaged devices.

With our ACE 109 and 118 blue breadboards, you simply plug in components and interconnect them with ordinary hook-up wire. All sizes of DIPs and other discrete components up to 22 gauge lead diameters snap right into the 0.1" x 0.1" matrix of the solderless tie points...anywhere on the layout. You don't need expensive sockets or special tools. Buses of spring clip terminals form a distribution network for power, ground and clock lines.

AP Products 100 series breadboards give you all the functions and flexibility of more expensive circuit evaluators. The spring terminals have mechanically independent contact fingers to

accommodate most DIPs and discrete components.

The ACE 109 has two terminals for separate voltages plus a ground connection. The larger ACE 118 offers the same three terminals, plus an additional terminal which can be used for clocking or another voltage. The backplates are heavy steel to keep the boards stationary.

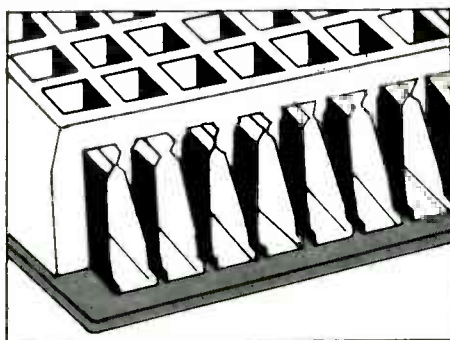

Don't wait. These low prices won't last forever. See your local AP Products dealer today, or send for a list of dealers in your area.

CIRCLE 76 ON FREE INFORMATION CARD



A P PRODUCTS
INCORPORATED

9325 Progress Parkway
P.O. Box 540
Mentor, Ohio 44060
800-321-9668
(Ohio, 216/354-2101)

Yes! I'm ready for breadboarding! Send:
 Names of dealers More information
Name: _____
Address: _____
City: _____ State: _____
Zip: _____

NEW IDEAS

Robot eyes

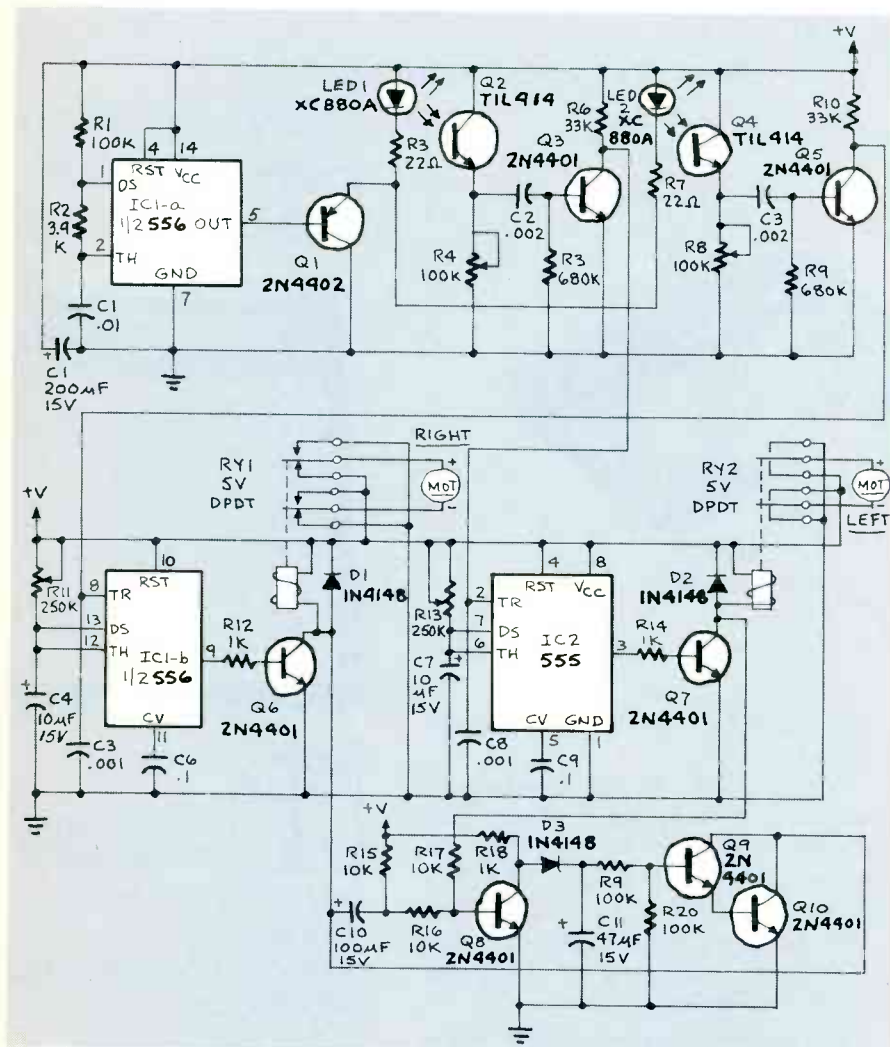

FIG. 1

I HAVE A TOY ROBOT THAT USES TWO small DC motors to move around. The robot was designed to move according to how its joystick was manipulated, but I wanted to make my robot intelligent enough to be able to move about on its own and avoid whatever obstacles happened to appear. I knew that I would find it difficult to move around if I had no eyes, so I figured that a pair of "eyes" would help my robot, too. The circuit shown in Fig. 1 represents the fruit of my labor.

shown in Fig. 1 represents the fruit of my labor.

Circuit operation

My robot has one motor mounted under both its left and right sides. The direction the robot moves depends on the direction each motor rotates. For example, the robot can go forward and backward by running both motors in the same direction. And the robot can turn by running one motor for-

NEW IDEAS

This column is devoted to new ideas, circuits, device applications, construction techniques, helpful hints, etc.

All published entries, upon publication, will earn \$25. In addition, for U.S. residents only, Panavise will donate their model 333—The Rapid Assembly Circuit Board Holder, having a retail price of \$39.95. It features an eight-position rotating adjustment, indexing at 45-degree increments, and six positive lock positions in the vertical plane, giving you a full ten-inch height adjustment for comfortable working.

I agree to the above terms, and grant **Radio-Electronics Magazine** the right to publish my idea and to subsequently republish my idea in collections or compilations of reprints of similar articles. I declare that the attached idea is my own original material and that its publication does not violate any other copyright. I also declare that this material has not been previously published.

Title of Idea

Signature

Print Name

Date

Street

City

State

Zip

Mail your idea along with this coupon to: **New Ideas Radio Electronics**
500-B Bi-County Boulevard
Farmingdale, NY 11735

ward and the other backward. For example, when the left motor rotates forward, and the right motor moves backward, the robot turns to the right.

It's easy enough to use DPDT relays to control the direction of the motors, but we still need some "smarts." I used an infrared LED and a phototransistor for each eye. The rest of the circuit processes the information provided by those eyes to control the relays.

Half of a 555 timer IC (IC1-a) functions as an astable multi-

Super DiskTM Diskettes

Now...Diskettes you can swear by, not swear at.

Lucky for you, the diskette buyer, there are many diskette brands to choose from. Some brands are good, some not as good, and some you wouldn't think of trusting with even one byte of your valuable data. Sadly, some manufacturers have put their profit motive ahead of creating quality products. This has resulted in an abundance of low quality but rather expensive diskettes in the marketplace.

A NEW COMPANY WAS NEEDED AND STARTED

Fortunately, other people in the diskette industry recognized that making ultra-high quality diskettes required the best and newest manufacturing equipment as well as the best people to operate this equipment. Since most manufacturers seemed satisfied to give you only the everyday quality now available, an assemblage of quality conscious individuals decided to start a new company to give you a new and better diskette. They called this product the *Super Disk* diskette, and you're going to love them. Now you have a product you can swear by, not swear at.

HOW THEY MADE THE BEST DISKETTES EVEN BETTER

The management of *Super Disk* diskettes then hired all the top brains in the diskette industry to make the *Super Disk* product. Then these top bananas (sometimes called floppy freaks) created a new standard of diskette quality and reliability. To learn the "manufacturing secrets" of the top diskette makers, they've also hired the remaining "magnetic media moguls" from competitors around the world. Then all these world class, top-dollar engineers, physicists, research scientists and production experts (if they've missed you, send in your resume to *Super Disk*) were given one directive...to pool all their manufacturing know-how and create a new, better diskette.

HOW SUPER DISK DISKETTES ARE MANUFACTURED

The *Super Disk* crew then assembled the newest, totally quality monitored, automated production line in the industry. Since the manufacturing equipment at *Super Disk* is new, it's easy for *Super Disk* to consistently make better diskettes. You can always be assured of ultra-tight tolerances and superb dependability when you use *Super Disk* diskettes. If all this manufacturing mumbo-jumbo doesn't impress you, we're sure that at least one of these other benefits from using *Super Disk* diskettes will:

- TOTAL SURFACE TESTING** - For maximum reliability, and to lessen the likelihood of disk errors, all diskettes must be totally surface tested. At *Super Disk*, each diskette is 100% surface tested. *Super Disk* is so picky in their testing, they even test the tracks that are in between the regular tracks.
- COMPLETE LINE OF PRODUCTS** - For a diskette to be useful to you and your computer, it must be compatible physically. *Super Disk* has an entire line of 5 1/4-inch and 3 1/2-inch diskettes for your computer.
- SPECIALLY LUBRICATED DISK** - *Super Disk* uses a special oxide lubricant which is added to the base media in the production of their diskettes. This gives you a better disk drive head to media contact and longer head and disk life.
- HIGH TEMPERATURE/LOW-MARRING JACKET** - A unique high temperature and low-marring vinyl jacket allows use of their product where other diskettes won't work. This special jacket is more rigid than other diskettes and helps eliminate dust on the jacket.
- REINFORCED HUB RINGS** - Standard on all 48 TPI *Super Disk* mini-disks, to strengthen the center hub hole. This increases the life of the disk to save you money and increase overall diskette reliability.
- DISK DURABILITY** - *Super Disk* diskettes will beat all industry standards for reliability since they will give you more than 75% of the original signal amplitude remaining even after an average (Weibull B-50) of 30 million passes. They are compatible with all industry specifications as established by ANSI, ECMA, ISO, IBM and JIS.
- CUSTOMER ORIENTED PACKAGING** - All *Super Disk* disks are packaged 10 disks to a carton and 10 cartons to a case. The economy bulk pack is packaged 100 disks to a case without envelopes or labels.
- LIFETIME WARRANTY** - If all else fails, remember, all disks made by *Super Disk* Inc., have a lifetime warranty. If any *Super Disk* diskette fails to meet factory specifications, *Super Disk* Inc. will replace them under the terms of the *Super Disk* warranty.
- SUPERB VALUE** - With *Super Disk*'s automated production line, high-quality, error-free disks are yours without the high cost.

Order toll free 800-USA-DISK

NOW...NAME BRAND QUALITY AT SUPER CE PRICES

Now, you can buy *Super Disk* brand diskettes directly from Communications Electronics at prices less than "unbranded" generic diskettes. Your data is valuable, so why take chances using a diskette that could be so unreliable that the manufacturer refuses to put their name on it. To save you even more, we also offer *Super Disk* bulk product where 100 diskettes are packed in the same box without envelopes or labels. Since we save packaging costs, these savings are passed on to you. Diskette envelopes are also available from us. These super strong and tear resistant envelopes are only \$10.00 per pack of 100. Use order # CV-5 for a 100 pack of 5 1/4" diskette envelopes.

39¢ per disk Quantity One

Our diskettes are packed 10 disks to a carton and 10 cartons to a case. The economy bulk pack is packaged 100 disks to a case without envelopes or labels. For best value, you should order in increments of 100 diskettes. Almost all diskettes are immediately available from *Super Disk*. With our efficient warehouse facilities, your order is normally shipped in less than a day.

SAVE ON SUPER DISK™ DISKETTES

Product Description	Part #	Super Disk price per disc (\$)
5 1/4" SSSD Soft Sector w/Hub Ring	6431-CA	0.54
5 1/4" Same as above, but bulk pack w/o envelope	6437-CA	0.39
5 1/4" SSDD Soft Sector w/Hub Ring	6481-CA	0.58
5 1/4" Same as above, but bulk pack w/o envelope	6487-CA	0.43
5 1/4" DSDD Soft Sector w/Hub Ring	6491-CA	0.64
5 1/4" Same as above, but bulk pack w/o envelope	6497-CA	0.49
5 1/4" DSQD Soft Sector (96 TPI)	6501-CA	0.99
5 1/4" Same as above, but bulk pack w/o envelope	6507-CA	0.84
5 1/4" DSHD for IBM PC/AT - bulk pack	6667-CA	2.07
3 1/2" SSDD (135 TPI) - bulk pack	6317-CA	1.67
3 1/2" DSDD (135 TPI) - bulk pack	6327-CA	1.99

SSSD = Single Sided Single Density; SSDD = Single Sided Double Density; DSDD = Double Sided Double Density; DSQD = Double Sided Quad Density. DSHD = Double Sided High Density; TPI = Tracks per inch.

BUY YOUR DISKETTES FROM CE WITH CONFIDENCE

To get the fastest delivery of your diskettes, phone your order directly to our order desk and charge it to your credit card. Written purchase orders are accepted from approved government agencies and most well rated firms at a 10% surcharge for net 10 billing. For maximum savings, your order should be prepaid. All sales are subject to availability, acceptance and verification. All sales are final. All prices are in U.S. dollars. Prices, terms and specifications are subject to change without notice. Out of stock items may be placed on backorder or substituted for equivalent product unless we are instructed differently. A \$5.00 additional handling fee will be charged for all orders with a merchandise total under \$50.00. All shipments are F.O.B. CE warehouse in Ann Arbor, Michigan. COD terms are available, in U.S. UPS areas for \$5.00 extra, and are payable with cash or certified check. Michigan residents add 4% sales tax.

For shipping charges add \$6.00 per 100 diskettes and/or any fraction of 100 5 1/4-inch or 3 1/2-inch diskettes for U.P.S. ground shipping and handling in the continental U.S. For 1,000 or more disks shipped to the continental U.S., shipping charges are \$4.00 per hundred diskettes. UPS 2nd day air rates are three times continental U.S. rates. For Canada, Puerto Rico, Hawaii, Alaska, or APO/FPO delivery, shipping is three times the continental U.S. rate.

Mail orders to: Communications Electronics Inc., Box 1045, Ann Arbor, Michigan 48106-1045 U.S.A. If you have a Visa or Master Card, you may call and place a credit card order. Order toll-free in the U.S. Dial 800-USA-DISK. In Canada, order toll-free by calling 800-CA1-DISK. If you are outside the U.S. or in Michigan dial 313-973-8888. Telex anytime 810-223-2422. Order your *Super Disk* diskettes now.

Copyright © 1986 Communications Electronics Inc.

Ad #030186-CA



**Now
39¢
a disk**

MARCH 1986

IF YOU WANT TO GET YOU HAVE TO GET INTO

Learn PC Servicing By Building Your Own NTS/HEATH HS-151 Desk-Top Computer, Circuit-By-Circuit

NTS Intrinsic Home Training Takes You Below The Surface

NTS gets you right down into the heart of computer circuitry. You learn how microprocessors function, how they are designed, how they operate and are used to solve problems. Your program includes a wide variety of tests and projects, as you assemble your PC. You experience the excitement of seeing your own skills grow, the security of knowing you really understand what makes a computer tick.

A Career in PC Servicing

The world of computers is constantly expanding. Applications have spread from business to manufacturing, from industry to medical and scientific fields. Computer-aided design, engineering, and production have revolutionized drafting, graphics, and prototyping. Computer sales figures point to a continuing need for service technicians as well as installation and maintenance specialists. The type of training you receive will largely determine your ability to take advantage of these opportunities and nothing beats the practical, down-to-earth training you get from NTS.

The NTS/HEATH 16-Bit HS-151

This desk-top PC is the most powerful and versatile ever offered in any home training program. Check the advanced features listed below:

1. 128 KB RAM user memory on board, expandable to 640 KB
2. 16-bit 8088 Microprocessor accepts advanced software, speeds word processing; also allows selection from the huge library of IBM software.
3. 5.25-inch floppy disk drive, double density, IBM formatted, stores up to 360 KB. (Expandable to dual disk drive, and optional 10.5 MB hard-disk drive.)
4. MS-DOS operating system, IBM compatibility, make a wide choice of software programs available.
5. Four open IBM-compatible slots provide for future expansion, printer, modem, etc. Will accept most peripheral boards designed for IBM-PC.
6. Two video outputs for color or monochrome display monitor. Your NTS course includes a high resolution monitor displaying 80 characters by 25 lines, or graphics.
7. Editing capabilities help you insert or delete characters and lines, erase, jump or smooth scroll, etc.

Your NTS training course will teach you to program on this outstanding PC, using lessons, texts, and diagrams to make full use of its capabilities. Catalog contains complete details.

**IBM
Compatible**



Learning circuitry through the construction of this equipment offers practical training for which there is no substitute. Test equipment is included.

Field servicing is interesting and rewarding. Technicians may work for a service company, manufacturer, or major users.

The NTS/HEATH HS-151 PC completed, includes monitor and full-function keyboard with calculator style keypad, and typewriter format.



INTO PC SERVICING A MICROCOMPUTER

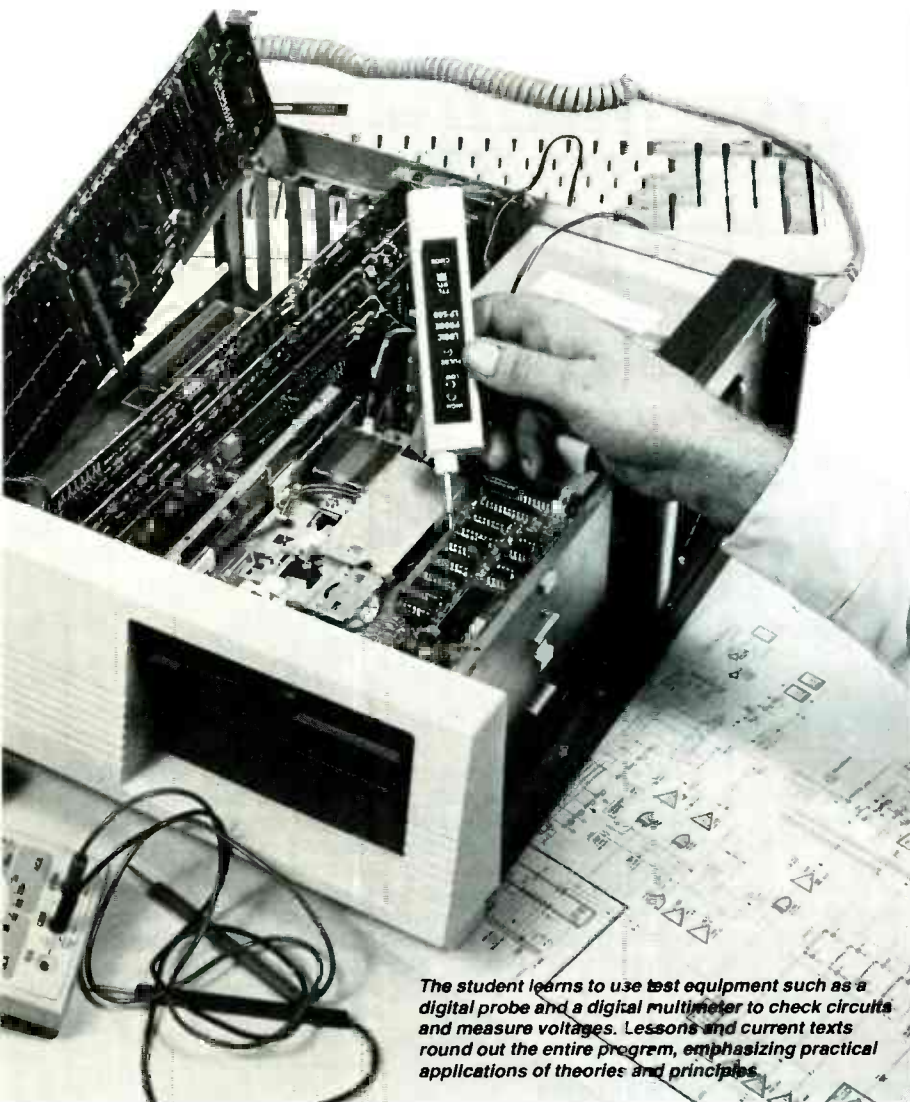

The student learns to use test equipment such as a digital probe and a digital multimeter to check circuits and measure voltages. Lessons and current texts round out the entire program, emphasizing practical applications of theories and principles.

Installing the disk-drive in the PC is one of the final stages in the assembly of the microcomputer. Learning the use of test equipment to check circuits is an integral part of the training which, with field experience, develops invaluable career skills.

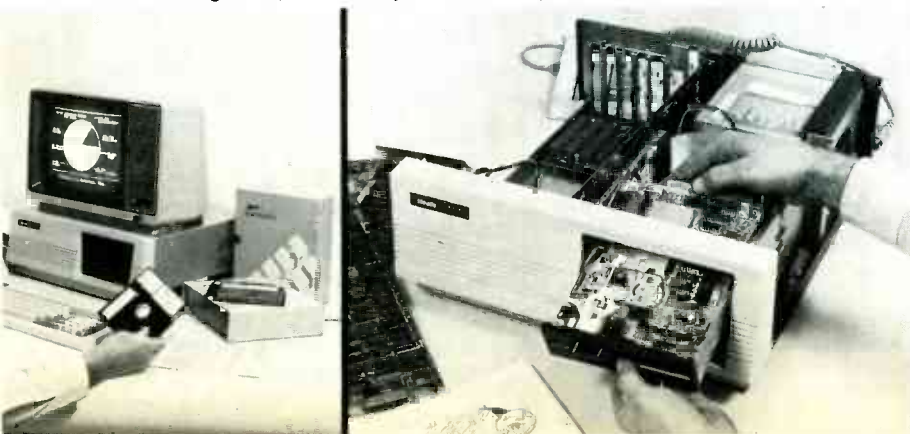

NTS COURSES COVER MANY AREAS OF SPECIALIZATION IN ELECTRONICS:

Robotics: Build the NTS/HEATH Hero 1 Robot as you learn robotic programming. Robot is complete with arm and gripper, voice synthesizer. Robotics is becoming increasingly important in industry as almost daily news features attest.

Video Technology: Build one of the most advanced Color TV sets in America as you learn circuit diagnostics, and the use of digital test instruments. Course covers color TV, video tape recorders, computer fundamentals, solid-state devices.

Industrial and Microprocessor Technology covers circuit analysis, microprocessors and automation applications, lasers, and basic industrial robotics.

TV & Radio Servicing is a specialized course offering an excellent foundation in the use and application of both analog and digital test equipment as applied to the TV servicing field. Learn circuits, adjustments, trouble-shooting, and servicing of Color and monochrome monitors.

Digital Electronics offers the student the opportunity to get involved with computer concepts, computer technology fundamentals, and digital equipment by training on the NTS Compu-Trainer.

Basic Electronics is a course designed for those wishing to have an over-view of electronics in many of its aspects including radio receivers, solid state devices, and electronic components.

NTS Intronic training programs include a variety of superb equipment, most of which is classified as field-type, making the training practical and career oriented. Texts and lessons have been tested in our Resident School in Los Angeles to assure home study students their courses of training are easy to understand. NTS, now in its 80th. year, continues to be at the leading edge in Electronics home training.

* IBM is a trademark of International Business Machines Corp.
* MS is a trademark of Microsoft Corp.

If card is missing, simply write to the address shown below stating the course you are interested in. A FREE color catalog with all details will be sent to you by return mail.

**NTS NATIONAL
TECHNICAL
SCHOOLS**

TECHNICAL TRADE TRAINING SINCE 1905
Resident and Home-Study Schools

4000 So. Figueroa St., Los Angeles, CA 90037

Radio-Electronics mini-ADS

vibrator oscillating at a frequency of about 1 KHz. That IC drives transistor Q1, which in turn drives the two infrared LED's, LED1 and LED2. The right eye is composed of LED1 and Q2; those components are mounted side by side—not facing each other—about ¼" apart. The left eye is composed of LED2 and Q4, which are mounted like the corresponding parts of the right eye, about four inches away.

If an obstacle appears in front of the right eye, pulses from LED1 are reflected by the obstacle and detected by Q2. The signal from Q2 is amplified by Q3, which triggers IC2, a 555. That IC operates in the monostable mode, and it provides a pulse output with a width of as much as 2.75 seconds, depending on the setting of R11. That pulse output energizes relay RY1, and that reverses the polarity of the voltage applied to the motor. Corresponding portions of the circuit of the left eye operate in the same fashion, using the unused half of the 556 (IC1-b). That action causes the robot to turn away from an obstacle.

When an obstacle appears in front of both eyes, both relays will be activated, so the robot will back up. The circuit composed of Q8-Q10 (and associated components) provides additional "on" time for the right motor. That helps the robot avoid getting trapped in a narrow passage.

Construction

Construction of the circuit is not critical, so feel free to use the technique you prefer. Just be careful with the orientation of polarized components and semiconductors. The circuit can operate from any voltage between 4.75 and 7.5 volts. Potentiometers R4 and R8 adjust the sensitivity of the phototransistors; you might adjust them to respond to an obstacle that is twelve inches away. Potentiometers R11 and R13 control the amount of time the motors will be reversed. That will depend partly on the surface your robot is traversing. Too little time on a rough surface might not affect direction at all, and too much time could cause constant overshooting. You'll have to experiment a little.—*John Ellis*



THE WIRELESS TELEPHONE TRANSMITTER model WTT-20 is only the size of a dime, yet transmits both sides of a telephone conversation with crystal clarity. Completely automatic. Uses power from the telephone line itself. Never needs a battery! Up to ¼ mile range. Use with any FM radio. Complete kit only **\$29.95**. Tax included. VISA and MasterCard accepted. **FREE SHIPPING. DECO INDUSTRIES, Box 607, Bedford Hills, NY 10507. (914) 241-2827.**

CIRCLE 127 ON FREE INFORMATION CARD



STEREO SOUND ON YOUR TV SET! Now you can receive true MTS stereo sound from your monaural TV set or VCR. Also compatible with "MTS stereo ready" TVs. Includes built-in true stereo simulator for stations not yet broadcasting in stereo. Only **\$159.95**. Quantity discounts. Also available: SSAVI descramblers & surplus cable TV equipment. Catalog **\$1** (first class). 90 day warranty. **AIS SATELLITE, P.O. Box 1226, Dublin, PA, 18917. (215) 249-9411.**

CIRCLE 271 ON FREE INFORMATION CARD



FREE CATALOG OF HARD-TO-FIND TOOLS is packed with more than 2000 quality items. Your single source for precision tools used by electronic technicians, engineers, instrument mechanics, schools, laboratories and government agencies. Also contains Jensen's line of more than 40 tool kits. Send for your free copy today! **JENSEN TOOLS INC., 7815 46th St., Phoenix, AZ 85044. (602) 968-6231.**

CIRCLE 115 ON FREE INFORMATION CARD

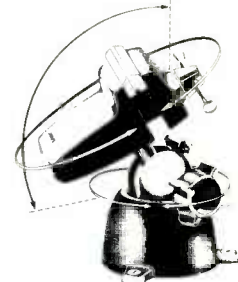

HOLD IT! ANYWHERE YOU WANT IT! MODEL 301 STANDARD PANAVISE. This all-purpose Standard PanaVise tilts, turns and rotates. Consisting of a Standard Base, Model 300 and a 303 Head, the 301 has nylon jaws with a satin finish for a firm grip. Just one convenient control knob locks work firmly in any position. **\$32.95. PANAVISE PRODUCTS, INC., 2850 East 29th Street, Long Beach, CA 90806-2399. Telephone (213) 595-7621. Telex 18-2135.**

CIRCLE 258 ON FREE INFORMATION CARD

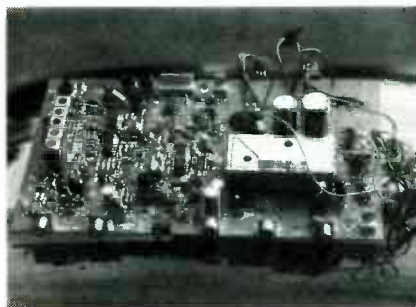

TVRO RECEIVER ON A BOARD fully tested and assembled. Super reception 7db threshold!! Includes weather sealed downconverter **\$125.00**. In cabinet **\$165.00**. Quantity discounts. Schematics only **\$10.00**. C band feeds. Yushica positively the best we've ever seen. Whatever you have, replace it. **\$65.00**. Private labels welcomed (50 units). **800-448-TVRO, SAUCER CITY. Office B7-B, 931 S. Ridgewood Ave., Edgewater, FL 32032.**

CIRCLE 279 ON FREE INFORMATION CARD



SUBSCRIPTION TELEVISION DESCRAMBLERS. These oak built, sinewave downconverter-descramblers are surplus pull outs and are worth many times this price in parts alone. Descramblers are untested and without A.C. cords. Send **\$19.95** in money order or cashiers check to **PAMER ELECTRIC SURPLUS, 12970 Brandford Street, Suite "M", Arleta, Cal. 91331. \$19.95** includes shipping and tax (where applicable).

Radio-Electronics mini-ADS

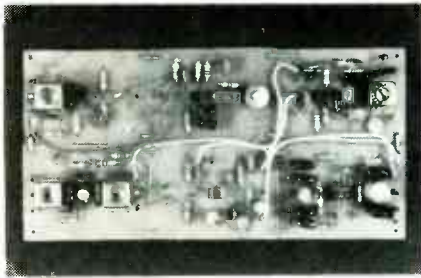

HOBBY KITS THE ERECTOR SET® of linear electronics. Modules from \$4.95 to \$49.95. Build basic circuits: 2 W audio amplifier (AFA-1, \$4.95), tone decoder (PLL-1, \$6.95), to more complex: VHF Converter (using 4 modules, \$27.80), QRP Transceiver (using 6 modules as shown, \$38.70), HF SSB Transceiver (using 14 modules, \$140.30). Add \$2.50 for S&H. SEND \$1.00 for diagrams, \$5.00 for full manual. **MORNING DISTRIBUTING CO.**, P.O. Box 717, Hialeah, FL 33011 (305) 884-8686.

CIRCLE 71 ON FREE INFORMATION CARD

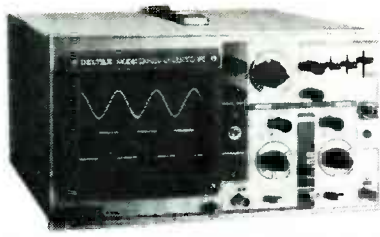

DELTA DUAL TRACE OSCILLOSCOPES WITH PROBES DX5020 20MHz \$379.95. Built in component tester 5MV to 20V/DIV 0.2 microsec. to 0.5s/DIV. Risetime less than 17ns one year limited warranty. Also available DX5035 35MHz \$527.00 DX5045 45MHz \$789.95 DX5015S 15MHz A/C D/C \$479.95. CA. residents add 6.5% tax. Shipping \$8.50. Money orders, checks accepted. **DELTA DYNAMIC INC.**, 20955 E. Lycoming St., Walnut, Calif. 91789. Tel. (714) 594-7131. Telex: 503749 DELTAX.

CIRCLE 264 ON FREE INFORMATION CARD



CORDLESS TV TRANSMITTER. This unit, a miniature video transmitter, conveniently transmits UHF signals to remote television locations within a 200' range. Signal inputs from VCR, Video Game, Satellite Receiver, Video Camera, or Micro Computer. When ordering select an open UHF channel for your area. CH 14, 19, 25, or 27. \$89.95 plus \$4.00 S&H. Visa/MasterCard call 1-800-522-2636 orders only, 617-871-5611 for information. **CAMEO ENTERPRISES, INC.**, P.O. BOX 63, Accord, MA 02018.

CIRCLE 276 ON FREE INFORMATION CARD



APPLIANCE REPAIR HANDBOOKS—13 volumes by service experts; easy-to-understand diagrams, illustrations. For major appliances (air conditioners, refrigerators, washers, dryers, microwaves, etc.), elec. housewares, personal-care appliances. Basics of solid state, setting up shop, test instruments. \$2.65 to \$5.90 each. Free brochure. **APPLIANCE SERVICE, PO Box 789, Lombard, IL 60148.** 1-(312) 932-9550.

CIRCLE 84 ON FREE INFORMATION CARD



TV STEREO-SAP-ADAPTER: only \$79.00 to modify your existing TV set as a Stereo-Second Audio Program-Function TV. It requires single line from TV and stereo amplifier. Detail instruction manual for modification is included. Allow 4-6 weeks delivery. **INTEK ELECTRONICS, P.O. BOX 76417, Los Angeles, CA 90076,** (213) 739-1664.

CIRCLE 287 ON FREE INFORMATION CARD



THE MOST EXCITING KIT YOU WILL EVER BUILD The model WAT-50 miniature FM transmitter uses a 4-stage circuit NOT to be confused with a simple wireless microphone. Up to 1 mile range. So sensitive, it will pick-up a whisper 50 feet away! Use with any FM radio. Complete kit only \$29.95 tax incl. VISA and MasterCard accepted. **FREE SHIPPING. DECO INDUSTRIES, Box 607, Bedford Hills, NY 10507.** (914) 241-2827.

CIRCLE 127 ON FREE INFORMATION CARD

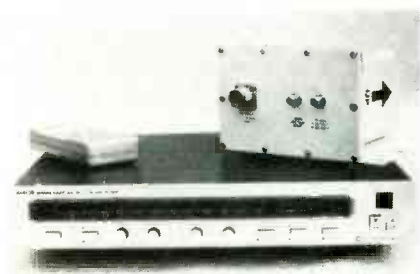

SATELLITE TELEVISION RECEIVER SEMIKIT with dual conversion downconverter. Features infrared remote control tuning, AFC, SAW filter, RF or video output, stereo output. Polorator controls, LED channel & tuning indicators. Install six factory assembled circuit boards to complete. **Semikit \$250.00.** Completed downconverter add \$75. Completed receiver and downconverter add \$100. **JAMES WALTER SATELLITE RECEIVER, 2697 Nickel, San Pablo, CA 94806.** Tel. 415-724-0587.

CIRCLE 124 ON FREE INFORMATION CARD



THE BEST TEST PROBES. NOW \$15.95. Huntron's patented μ Probes feature extendable tips that get into tight places. Stainless steel electrodes are insulated with a 2 kV coating to protect against shorting. Sharp points pierce epoxy and won't slip off contracts. μ Probes are excellent replacement leads for most test instruments. \$15.95 PLUS \$2.00 P&H. CHECK, VISA or MC. 1-800-426-9265 **HUNTRON INSTRUMENTS, INC.**, 15123 Hwy. 99 N., Lynnwood, WA 98037.

CIRCLE 281 ON FREE INFORMATION CARD



SUBSCRIPTION TV MANUAL. This information packed book details the methods used by subscription TV companies to scramble and descramble video signals. Covers the Sinewave, Gated Pulse, SSAVI system, and the methods used by most cable companies. Includes circuit schematics, theory, and trouble shooting hints. **Only \$12.95 plus \$2.00 first class P&H. ELEPHANT ELECTRONICS INC., (formerly Random Access) Box 41770-R, Phoenix, AZ 85080**

CIRCLE 120 ON FREE INFORMATION CARD

Now electronics technicians can get into VCR Servicing quickly and easily

Learn professional VCR servicing at home or in your shop with exclusive videotaped demonstrations

Today, there are more than 10 million VCRs in use, with people standing in line to have them serviced. You can bring this profitable business into your shop with NRI professional training in VCR servicing. This top-level training supports the industry's claim that the best technicians today are those who service VCRs.

Integrated Three-Way Self-Teaching Program

In one integrated program, NRI gives you a study guide, 9 instructional units, 2 hours of video training tapes accompanied by a 32-page workbook that pulls it all together. At home or in your shop, you'll cover all the basic concepts of video recording, mechanical and electronic systems analyses, and the latest troubleshooting techniques. Your workbook and instructional units also contain an abundance of diagrams, data, and supplementary material that makes them valuable additions to your servicing library.

The "How-To" Videotape

Your NRI Action Videocassette uses every modern communications technique to make learning fast and easy. You'll enjoy expert lectures and see animation and video graphics that make every point crystal-clear. You'll follow the camera eye into the heart of the VCR as step-by-step servicing techniques are shown. Both electronic and mechanical troubleshooting are covered . . . including everything from complete replacement and adjustment of the recording heads to diagnosing micro-processor control faults.

Plus Training On All The New Video Systems

Although your course concentrates on VCRs covering Beta, VHS, and 3/4" U-Matic commercial VCRs, NRI also brings you up to speed in other key areas. You'll get training in capacitance and optical video disc players, projection TV, and video cameras. All are included to make you the complete video technician. There's even an optional final examination for NRI's VCR Professional Certificate.

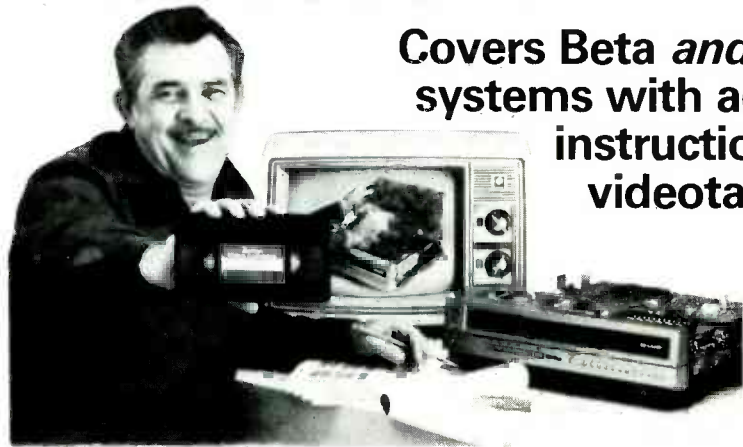

Covers Beta and VHS systems with actual instruction on videotape.

The Best Professional Training

This exclusive self-study course has been developed by the professionals at NRI. NRI has trained more television technicians than any other electronics school! In fact, NRI has consistently led the way in developing troubleshooting techniques for servicing virtually every piece of home entertainment equipment as it appears in the marketplace.

Satisfaction Guaranteed . . . 15-Day No-Risk Examination

Send today for the new NRI Self-Study Course in VCR Servicing for

Professionals. Examine it for 15 full days, look over the lessons, sample the videotape. If you're not fully satisfied that this is the kind of training you and your people need to get into the profitable VCR servicing business, return it for a prompt and full refund, including postage. Act now, and start adding new business to your business.

Special Introductory Offer

This complete VCR training course with two hour videotape is being offered for a limited time only, on orders received from this ad, at our low introductory price of \$179.95. Save \$20 by acting now!

NRI Training For Professionals
McGraw-Hill Continuing Education Center
3939 Wisconsin Avenue Washington, DC 20016

YES! Get me started in profitable VCR servicing. Rush me my NRI self-study course in VCR Servicing for Professionals. I understand I may return it for a full refund within 15 days if not completely satisfied.

PLEASE SPECIFY TAPE FORMAT DESIRED VHS BETA

Name (please print) _____

Company _____

Street _____

City/State/Zip _____

Enclosed is my check money order for \$179.95 (D.C. residents add 6% tax) Make check payable to NRI

Charge to VISA MasterCard _____

Interbank Number _____

Card Number _____ Expiration Date _____

Signature _____

(required for credit card sales)



NRI Training For Professionals
McGraw-Hill Continuing
Education Center
3939 Wisconsin Avenue
Washington, DC 20016

2600-036

BUYER'S GUIDE TO

Personal Robots

MARK J. ROBILLARD

ONCE FOUND ONLY IN INDUSTRY AND THE laboratory, over the past decade the computer has become a fixture in the vast majority of households. Now, the robot stands on the verge of making a similar transition; just as the "personal" computer is now commonplace, soon the "personal" robot will be found in many homes.

Personal robots hold the promise of creating even greater excitement than the computer. With their capabilities of movement and manipulation, personal robots have the potential to interact extensively with every member of the family. Blasphemous as it might seem, robots might even replace the family dog in some households.

So where are all of these robots? How close are we to that robot "explosion"? What are the capabilities of the robots that are currently available? Where can you obtain such a robot? Those are just some of the questions that we'll answer in this article.

What is a personal robot?

Most of you are probably familiar with the uses of robots in industry. Numerous television and film documentaries, most notably on PBS, have shown industrial robot-arms painting cars in Detroit or removing blistering-hot liquid from a furnace in Pennsylvania. Those examples depict the industrial use of robotics to improve production under somewhat hazardous factory conditions. But robot arms are not the entire realm of robotics. For that matter, robot arms, though most common, do not represent the only possible industrial application of robotics. Indeed, the possibilities are almost endless.

The same can be said for a "personal" robot. A personal robot can take almost any form, as long as it does not require an "industrial" environment in which to operate (not too many of us have pneumatic tubing, etc. running throughout our homes).

All of us can think of possible applications for mechanical slaves around the house. Some of the more obvious uses would be mowing the lawn, washing clothes and taking out the garbage. Others include vacuuming the carpets and walking the dog. Unfortunately, the scope of those applications is too ambitious—beyond the capability of most currently available robots; and that is severely limiting the market.

The robots are coming! The robots are coming! Find out when, and what form they'll take, in this informative survey of the personal-robot field.

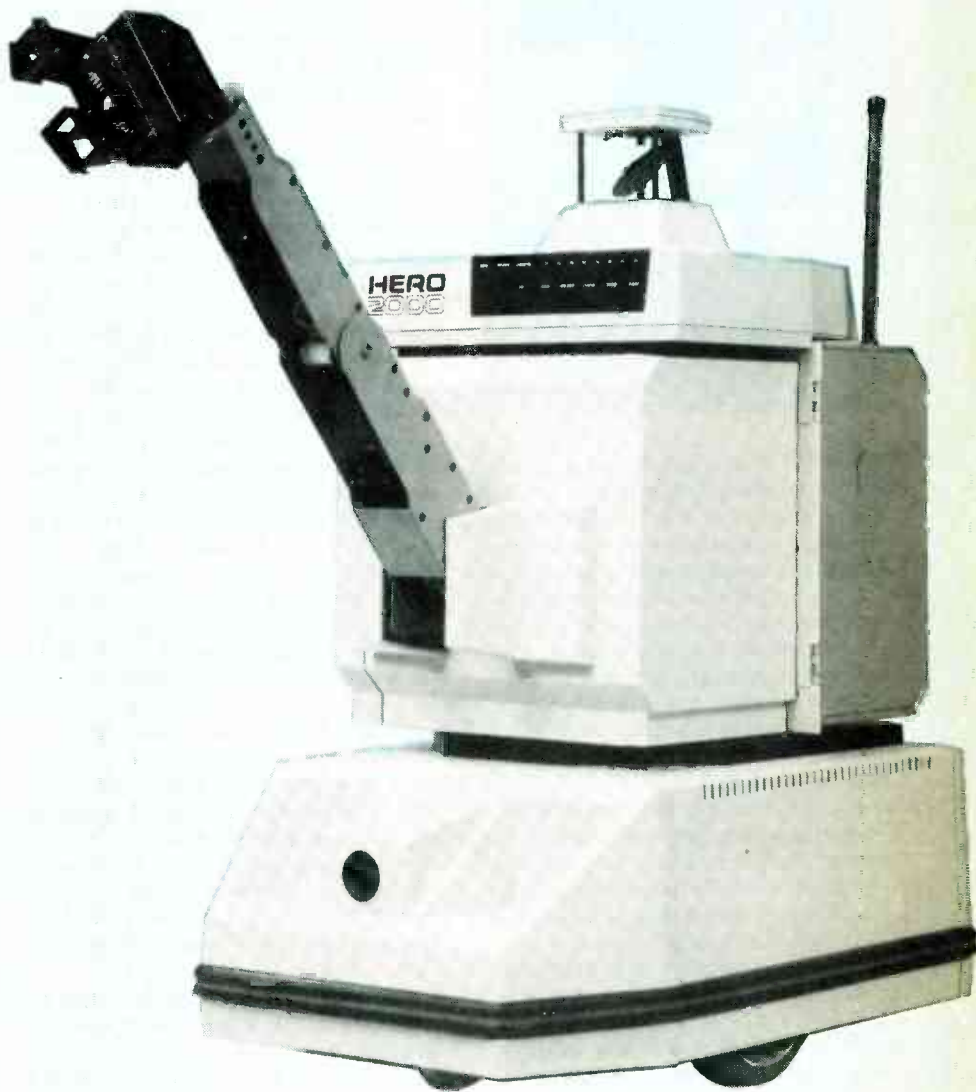

By the mid 1980's, hundreds of thousands of people owned personal computers. But many of those computers, particularly the less expensive ones, eventually wound up in the back of the closet. Once the novelty of the new machine wore off, the reality was that only a relatively

small number of people had a real need for a computer in the home; for everyone else, it was a device without an application. The situation with personal robots is very different. There, we have many applications, but no machine yet that is capable of performing more than a few of them.

In mid-1982, a company called RB Robot, operating in Golden, Colorado, introduced the first commercially available personal robot. The *RB-5X* looked to be little more than a trash can with wheels and a clear plastic top. A closer look revealed that that machine was equipped with collision sensors and a full-fledged microcomputer system that could be programmed in BASIC.

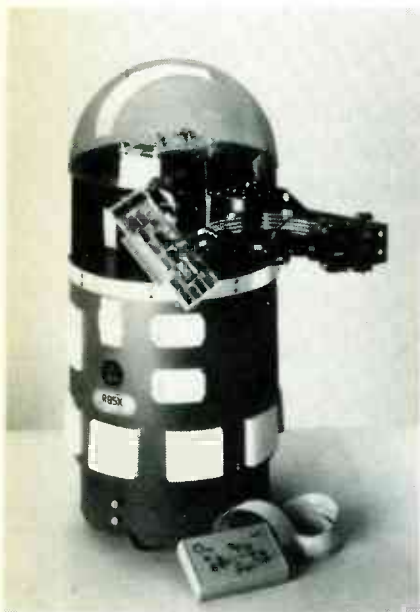

THE FIRST ROBOT, *RB5X* from RB Robot.

The *RB-5X* was basically a toy for the dedicated hardware experimenter. Its mechanical abilities were not much more refined than a radio-controlled car. The microcomputer could only be programmed by using an external dumb terminal—something that is not found in most households. But it did provide a starting point for would-be robot experimenters.

Shortly after the birth of the *RB-5X*, the Heath company announced the birth of what was to become the best-selling personal robot to date, the *Hero 1*. That robot, like the *RB-5X*, was equipped with a motorized base and microcomputer. However, included with the package were several sensors for measuring light, sound, motion, and distance. Those, and the addition of an arm and voice-synthesis module, placed the *Hero* more firmly into the category of what everyone thinks of when the word "robot" is mentioned. Much like early personal computers, the *Hero* could be programmed via a keypad.

If one were to plot a time-line of the history of personal robots versus that of the PC it would show that the *Hero* is the robotic equivalent of the *Altair* microcomputer.

Since those beginnings several things have happened. Many other firms have entered the market with robot kits and completely assembled units. A Texas-based marketing-research firm, Future

Computing, has forecast that the personal robotics market would be larger than that for the personal computer, and that that market was about to "take off." Many small firms entered the market with kits and assembled units.

In 1984, a magazine survey showed that there were 18 viable robotics products and manufacturers to choose from. Those products ranged from simple two-wheeled remotely operated devices called "turtles" to large-android-like, sophisticated robots. Many of the fledgling robotics firms were exceedingly small, some operating out of their owner's homes, or sharing space with other companies. Some sold only a few units; others, like *Androbot*, sold several hundred. In the latter case, *Androbot's* main product, called *Topo*, appeared to be an ideal robot system. It was large (the size of a six-year-old child) and, it had a unique drive-wheel system. The initial units ran via a special interface to an *Apple II* computer. They came with a disk of software routines that allowed the user to control the robot's motion via the computer's joystick.

One obvious limitation of the *Topo* was that it was incapable of undirected motion. *Androbot* promised to correct that problem in a proposed robot named *BOB*; that name was an anagram for *Brains On Board*. While full details were not released, indications were that the robot would be equipped with on-board microprocessors. Those microprocessors would analyze the data from "vision" sensors and use that data to control the robot's motion. Using that system, the robot reportedly would be able to seek out or follow its owner, even in a crowded room.

But, then what? The robot was not to be equipped with any manipulative capabilities (it had no "arm"), so what did it do when it approached the owner? Its only ability was to tell a joke, via a voice-synthesis circuit, from a stored library.

Obviously, such hardware is not sufficient to launch a new marketplace. The chief problem remains one of supplying the hardware that will perform an application that many people want. It is the opposite of the problems in the computer industry where the hardware exists, but finding an appropriate application is difficult.

Of the companies currently producing robots, Heath has done well because they designed their robots to be used as teaching tools, and they support them with a wealth of excellent study courses. Others have tried to produce either a general-purpose motorized toy that can only move and slightly entertain, or, on the other extreme, a high-priced replacement for a 95-cent joke book.

Today, despite optimism and high hopes, the personal robotics industry is unstable, to say the least. Of those companies that have already introduced robot

products, about half have faded from the scene altogether, or are not currently in a position to adequately service the consumer. There are, of course, new manufactures appearing (and unfortunately disappearing) on the scene all the time.

Even large companies are not immune to the vagaries of the current market. Several toy companies have introduced robot products. Those products are *not* toys; many compare favorably with the RB and Heath robots already mentioned. The forerunner among that group were Ideal and Tomy. The mechanics in their products were elegant; and because toy companies are so cost-conscious, all the mechanical parts were designed to have multiple functions.



IDEAL TOY'S *Maxx Steele*.

Tomy's *Omnibot* series of programmable robots is now the leader in the field with three entries. Ideal marketed a programmable version of the popular cartoon character *Maxx Steele*. That robot was designed specifically for upgradability. It had an Atari-like cartridge port for additions and a serial interface to its RF remote-controller. The documentation suggested that an expansion port and a sonar interface would be available in the future.

Now, that future seems to be a long way off. In November of 1985 the division of Ideal responsible for *Maxx Steele* was sold off, thereby burying the product.

Our survey

To find out the state of the market, we contacted over 20 personal-robotics manufacturers. Their products were investigated—we followed the same steps that you would in purchasing a personal robot. All products mentioned in this article were available for general sale at press time. The prices quoted were accurate at the end of 1985. In all but one case, the author has actually viewed and/or tested the product listed.

Obviously, all the features of each

product could not be listed in tabular form; however the most prominent features are listed in Table 1. Also, each product is described in more detail below. All of the robots have been listed in one of four general categories; arms, turtles, rovers, and miscellaneous. All the arm products are just that. They contain no provision for mounting a base or other rover-like features. Turtles are small rover-like machines that are slaved to a personal computer. They require a cable, power supply, and some software running in the host computers. Rovers are complete robot systems that contain an on-board microcomputer and the ability to maneuver about a room. Some, but not all, include arms as well as other advanced features such as voice I/O and vision-sensor systems. In "miscellaneous" we will look at some robot products that do not fit into our other categories.

Arms

The Rhino Robots (3204 N. Mattis Ave., Champaign, IL 61320) XR series arms are 5-axis machines and include grippers. Built using aircraft-grade aluminum, those robots are of fine quality. The motors that run the arm are servo type; they are DC motors that have integral optical encoders. Pulses from the encoders tell the microcomputer controller of the position of the arm. The motors drive the linkages through a series of chain drive belts. The robot has the heaviest lifting capabilities of any similarly priced product—almost three pounds.

The arms themselves are only a small part of the entire automation system that is supplied. Simple ASCII commands are used to operate all motors; a microprocessor-based control is located in the base of the arm. Interaction with the "outside world" is provided via an RS-232 interface.

Several other robot devices and services are offered by Rhino. For instance, they provide indexing tables and controllable conveyer belts. With those, it is possible to create a complete, working assembly-line operation.

One note on all of that: Rhino quality does not come cheap. Figure on spending about two thousand dollars for a very basic set of materials.

Microbot's (453 Ravendale Drive Mountain View, CA 94043) *Alpha* arm was the first to arrive in the personal robot field. It is similar to the XR Series from Rhino. However, all the motors are stepper types and the arm is moved via a cable system; that cable system is much like the ones used by the toy steam-shovels that you may have played with when you were young. The arm mechanics are enclosed in a rather attractive package. The arm can be computer-controlled via an RS-232 interface.

The *Alpha* arms, like those from Rhi-

no, are high-quality units. The most significant difference between the two is the use of stepper motors in the *Alpha*; that allows for a greater degree of repeatability. (That is important if repetitive tasks, such as those found on an assembly line, are to be performed). Despite their relatively high cost, there is no other product currently on the market that will do if you have a serious interest in arms or manipulators. Those arms are miniature versions of the ones found in industry.

Turtles

Frank Hogg Labs (Regency Tower, Suite 215, 770 James St., Syracuse, NY 13203) has been supplying software and accessories to users of 6800 family of microprocessors for many years. Recently they've introduced an excellent turtle for the TRS-80 *Color Computer*. Called *Nomad*, that turtle comes complete with a well-written manual and a wealth of demonstration programs. The *Nomad* itself is equipped with a two-stepper-motor drive and an on-board ultrasonic ranger. The software extends the BASIC already in the computer to allow for motion commands. Considering its \$250 price, the *Nomad* stacks up as quite a value.

The *Nomad* is by far the easiest turtle to control to date. It is much more sophisticated than the earlier devices that you might be familiar with. Typically, those were little more than DC motors and four micro switches connected to a computer. Although those devices sold well to schools investigating the benefits of the LOGO programming language, they were useful for little else.

Even more sophisticated is Rhino Robot's *Scorpion*. That unit is the most full-featured turtle on the market today. In fact we hesitate to classify it as a turtle because it has on-board "intelligence". But it still needs to be linked to a host computer for control, and it requires an external 12-volt, 5-amp power source.

The most prominent features of the *Scorpion* are its software command set, and its vision scanner. The latter has the ability of scanning an area in front of the robot and reporting the varying light levels encountered.

The on-board "intelligence" that we mentioned consists of a 6502-based controller and 2K of RAM. The RAM stores both the commands sent to it and the samples of ambient light taken by the controller. The on-board computer can be expanded, but the interface uses the old KIM standard.

Perhaps the most serious drawback of the unit is that it is only available in kit form. Normally that would not present a problem, especially to regular readers of **Radio-Electronics**; however, the assembly documentation is absolutely terrible. As such, its assembly can only be recom-

mended for someone with a great deal of project building experience.

Rovers

Artec Systems' (9104 Red Branch Rd., Columbia, MD 21045) *Gemini*, which is shown on the cover of the magazine, is one of the more advanced personal rovers available.



THE GEMINI robot from Artec systems.

The unit features an advanced on-board 65C02-based control system. Altogether there are three microprocessors. One is used as the main control computer; it is supplied with 64K of ROM and 56K of RAM. A second 65C02 is used to control the sound functions (voice I/O, sound generation, etc.); it has 25K of ROM and 16K of RAM. The third microprocessor is the motion-control computer; it is supplied with 2K of ROM and 24K of RAM. Its navigation system includes 9 ultrasonic collision-avoidance sensors. In addition, there is an LCD readout and detachable keyboard for programming in BASIC, and provisions for the addition of an on-board mass-storage device (either wafer tape or 3.5-inch floppy disk). *Gemini* will seek out its charging base when its batteries run low.

The machine performs well and its documentation is excellent. For those who want to build their own variation of the *Gemini*, the manufacturer will sell all the parts that go into it separately, including the shell! Unfortunately there is no arm yet available for the unit.

Heath (Benton Harbor, MI 49022) is the IBM of the personal-robot world. It's *Hero* family ranges from a preprogrammed pet-like robot, named *Hero Jr.*, to the most sophisticated robot commercially available today—*Hero 2000*. All Heath robots come in pre-assembled and kit form.

TABLE 1—

Manufacturer	Model	CPU Type	Memory	Drive System	Interface	Arm	Voice	Lift Capacity
ARCTEC SYSTEMS	GEMINI	65C02	56K	4 wheels DC servo	multiple	no	yes	none
FISHER AMERICA	ROBOT COMPUTING KIT	none	none	2 mini motors	multiple	see text	no	N/A
FRANK HOGG LABS	NOMAD	TRS80 Color	none	2 wheels DC stepper	TRS80 Color	no	no	none
HEATH COMPANY	HERO 2000	8088	24K up to 576K	DC servo	remote RF, RS232C	option	yes	1 lb
HEATH COMPANY	HERO 1	6808	4K up to 56K	DC and stepper	remote RF, RS232C	option	yes	1 lb
HEATH COMPANY	HERO Jr.	6808	2K	DC and stepper	remote RF, RS232C	no	yes	none
IDEAL div CBS TOYS	MAXX STEELE	65C02	4K	2 wheels DC servo	remote RF	yes	yes	1 lb
MICROBOT INC.	ALPHA	none	none	DC stepper motors	RS232C	yes	no	1 lb
NINTENDO	ROB	N/A	N/A	N/A	none	yes	no	N/A
RB ROBOT INC.	RB-5X	INS8073	8K, 16K	DC motors	RS232C	option	option	1 lb
RHINO ROBOTS INC.	XR	8748	none	DC Servo	RS232C	yes	no	2.2 lbs
RHINO ROBOTS INC.	SCORPION	6502	2K	2 wheels DC stepper	RS232C	no	no	none
ROBOT SHACK	X-1	none	none	DC motors	none	no	no	none
ROBOT SHACK	Z-2	none	none	large DC motors	none	no	no	none
ROBOT SHACK	Z-1	none	none	DC motors	none	no	no	none
ROBOT SHACK	DROID BUG	none	none	DC motor	none	no	buzzer	none
TOMY	OMNIBOT 2000	N/A	audio tape	DC motors	remote RF	yes	recorded	1 lb
TOMY	OMNIBOT	N/A	audio tape	DC motors	remote RF	manual	recorded	none
TOMY	VERBOT	N/A	N/A	2 wheels DC motor	voice input	yes	input	4 oz
TTC CORPORATION	HEAROID	N/A	N/A	DC motors	remote RF	manual	input	4 oz

The *Hero Jr.* sports a 6808 micro-processor and a ROM that has been programmed with a selection of songs and activities. With the addition of an optional ROM cartridge adapter, the robot can accept a BASIC language cartridge that allows the user to program its action much like its older brother, *Hero 1*. Other options include an RF remote console for putting the robot through its paces without need of a connecting cable, and a number of pre-programmed demonstration and utility cartridges.

As mentioned, the *Hero Jr.* is a scaled-down version of the *Hero 1*. In its basic form, the latter computer is supplied with just 4K of RAM, but that can be expanded to 56K through an optional internally-mounted board. That robot comes equipped with practically every sensor you could want, including sonic ranging. Options include a somewhat limited-use arm, a Votrax SC01-based voice synthesizer, and an RF remote-control console. That console mimics the one mounted on the robot itself (that is located in the "head" area). Via the remote console, a wireless link between a host computer or terminal and the robot can be established. Among the available options are a limited version of BASIC and complete training courses in industrial electronics and robot applications. The courses are particularly worthwhile; you might want to consider obtaining them separately if you build your own robot. As an example, the applications course provides a wealth of robotics experiments, ranging from simple vision projects to tactile sensing.

The newest addition to the family is the most powerful robot available. It has many times the capabilities of the *Hero 1*, and costs only slightly less than twice as

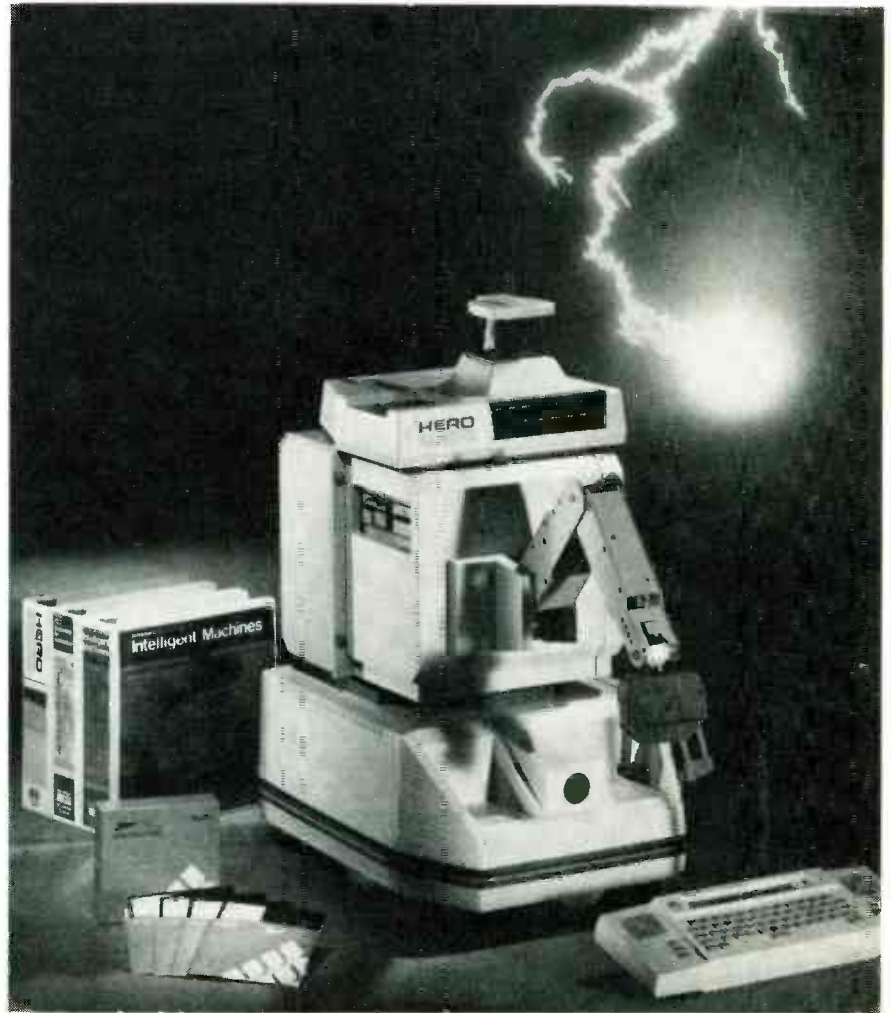

HERO 2000 from Heath.

much! That robot is the *Hero 2000*. Unlike Heath's other robots, that unit makes use of 80C88 microprocessors; it comes with 24K of RAM, expandable to 576K.

An internal expansion bus has slots for up to 12 expansion boards. Individual microprocessors are used to control a variety of functions, ranging from operating the ser-

PERSONAL ROBOT COMPARISON CHART

Expandability	Other Features	Price
Apple Bus Can be combined w/other Fisher kits	Sonic ranging, keyboard, disc drive 10 project kit	assemb. \$6995 kit \$3595 N/A
None	Sonic ranger, extension to Color Basic	assemb. \$250
S100-like Bus	Complete robot system, optional disc drive, MS DOS-like operating system	assemb. \$4500 w/arm kit \$3000 w/arm
Memory and serial boards etc.	Complete courses on hardware, BASIC Demo ROMS, RF remote option	assemb. \$1700 kit \$800
Cartridge port, external sensors	Built-in games, songs expandable with BASIC cartridge, RF remote option	kit \$400
Cartridge port	Serial interface to remote controller, built in games, programming language	assemb. \$399
None	Full feature arm with 6 degrees of freedom	N/A
N/A	Part of videogame system	N/A
44 pin Bus, many options	Sonic ranger, tactile sensors, robot programming languages, courses	assemb. \$2540 (base, voice) \$1395 w/arm
None	Full feature arm with 6 degrees of freedom	N/A
KIM Bus	Optical scanner, 8 tactile sensors	kit \$299
Can add complete computer	Robot base motors and structure plus controls for 25 lb robot	kit \$399
Can add complete computer	Robot base motors and electrical controls for 100 lb robot	kit \$250
Can add complete computer	Robot base motors and electrical controls only for 25 lb robot	kit \$150
None	Wired robot bounces off objects and changes direction	kit \$130
External sensors for light, etc.	Built-in tape recorder, One arm powered, head moves, optional computer interface	assemb. \$399
None	Built-in tape records program steps, Two arms are manually operated	assemb. \$199
None	Programs by training commands using remote microphone	assemb. \$60
External sensors for light etc.	Built-in tape records program steps, Voice recognition through wireless mic	assemb. \$299

vo-motor base-motion system to determining distance from an object via ultrasonics. The arm offered with the unit compares favorably with the ones offered by Rhino and Microbot. Rounding out the features are a self-recharging power supply and a sophisticated voice-synthesis system.

Heath's major difficulty with that robot may be in the area of marketing. The *Hero I's* limited mechanical abilities disappointed many, and it may be hard to convince would-be buyers that there truly is a difference. There is! See the robot in action and you're sure to want one, even if it does cost around \$3000.

Tomy Toys (901 E. 233 St., Carson, CA 90749) is the largest selling toy robot manufacturer. Several years ago, they introduced a mechanical arm that is now sold exclusively through Radio Shack stores. Their family of true robots ranges from an inexpensive voice-operated unit to a sophisticated double-armed remotely-operated one.

Verbot, the voice-activated unit, is a small (under 12-inches) robot with a pair of arms and a dome head. Inside is a microprocessor-based voice-recognition system. The user pushes one of the operation-function buttons on the front of the robot, then speaks the command word. Thereafter, speaking that word will activate that function. The functions that can be activated in that manner include motion in the four basic directions (left, right, front, and back) and a grasp and release command for picking up very light objects with the arm. *Verbot* is technically sophisticated, yet its cost is fairly low (around \$50).

Shortly after the introduction of *Verbot*, Tomy came out with the first member of the *Omnibot* series. That robot was taller than *Verbot* and sported an internal audio-

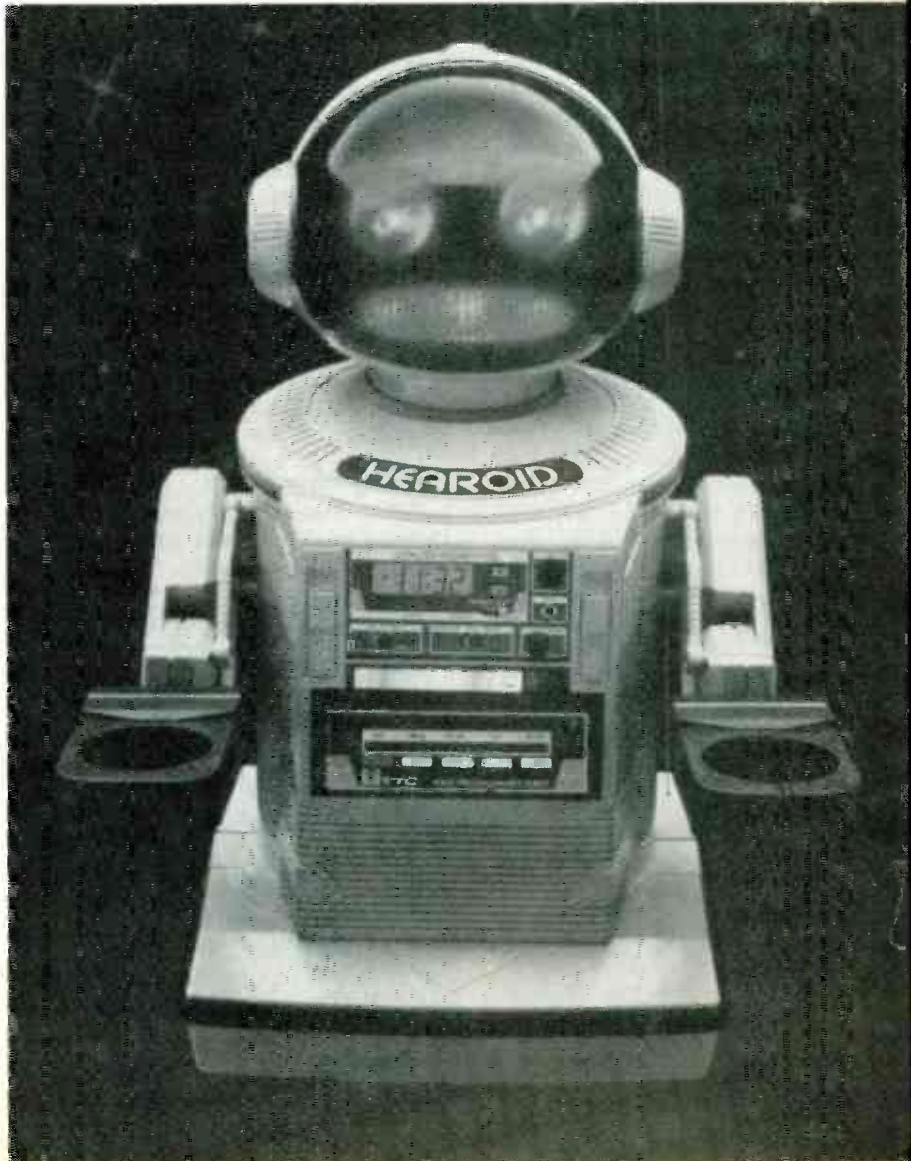

TTC's Heroid.

cassette recorder/player that could be used to store commands sent to the robot via its RF remote-command module (included). The unit has two manually-operated arms and the ability to receive your voice through a wireless microphone built into the RF remote.

That initial *Omnibot* still was limited by its small size. Recently, Tomy introduced a much larger version, called the *Omnibot 2000*. It has two arms with very functional three-fingered grippers. Unfortunately only one of the arms is powered. In addition, the robot comes with a unique tray for serving beverages. The robot can activate the tray, which has built-in cup holders; those holders move the cups under the robot arm automatically.

Although the expansion capabilities of the series do not match those of the *Hero* series, there should be plenty for the hobbyist to explore. Tomy plans on introducing both an infrared sensor and a sonic ranger.

The TTC Corporation (2009 East 233rd St., Carson, CA 90810), a spin-off from Tomy, is also offering a robot, called *Heavoid*, that has many of the features of the *Omnibot* and the *Verbot*. In addition, an optional videocamera is available; that opens up some interesting applications in the area of security.

RB Robot (14618 W Sixth Ave., Suite 115, Golden, CO 80401), is still producing the *RB-5X*, the first personal robot. That unit, of course, has gone through a number of changes and enhancements over the years. The current version is as expandable as the *Hero 1*. To go into detail, the *RB-5X* uses an INS8073 microprocessor. That National Semiconductor IC is set up to execute a version of Tiny BASIC. Programming is done via an external terminal or host computer. Communication is via an RS-232 interface. The robot comes with 8K of RAM; that can be upgraded to 28K. The on-board system can be expanded via add-on cards; a 44-pin card-edge connector has been provided for that. Sensors include a Polaroid ultrasonic rangefinder, and an infrared transceiver.

Lately, RB has been in reorganization following some rough business climates. Their main thrust now is aimed at the educational market, which has been perceived by the company as the only real avenue left in the field. To go along with that, an entire robot-learning course has been developed along the same lines as the industrial courses offered by Heath.

Robot Shack (PO Box 582, El Toro, CA 92630) provides plans and parts for a number of robot systems. Those systems would have to be considered low-end or experimental in nature, however. Further, though the company would appear to be a

The company offers four robots in all. Their *Droid Bug* is an electro-mechanical motorized unit with a bumper switch.

good source for robot parts, etc. at first glance, closer examination reveals that that might not be the case.

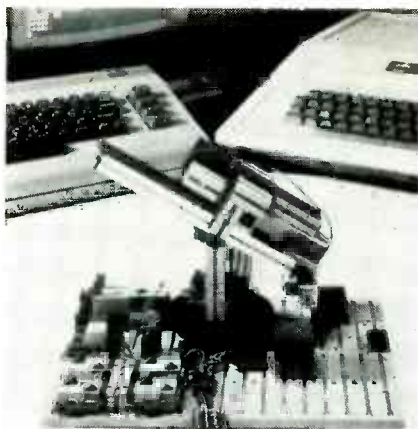

FISHER AMERICA'S *Robotic Computing Kit*.

When the bumper contacts an object, the motors reverse direction. That "robot" has no provision for adding any type of computer control.

The *Z-1* appears to consist of a motor from a Milton-Bradley *Big-Trak*, some wheels, and six switches. Those switches are all that comprise the robot's "control system." At \$149.00, you might find that you can do much better scrounging the parts on your own.

The *Z-2* is not much better. For \$249 you get two heavier duty motors (available on the surplus market for about \$24.00 apiece), the same switch package as the *Z-1*, and about \$10.00 worth of furniture castors and hook-up wire.

Finally, the *X-1* adds some lights, sound effects, and a device called a "function cycle timer." It costs \$399.00.

Miscellaneous robots

Fisher America's (Parsec Research, Drawer 1766, Fremont, CA 94538) *Fisheerchnik Robot Computing Kit* offers a



YOU CAN PLAY VIDEOGAMES with *ROB*, from Nintendo.

fascinating introduction to the world of robotics for someone who is completely new to the field. Resembling somewhat the *Lego* plastic construction blocks we all played with as children, that product includes the parts and plans to build 10 computer-controlled robotic projects including a sorting system, materials lift, computer plotter, and a "teachable" robot arm. An interface for connection to an IBM *PC*, a Commodore, or Apple computer is also provided, as is a disk of BASIC programs designed to help the novice computer programmer the most from his creations.

Finally, computers, for the most part, first entered our home in the form of entertainment devices (i.e. video games). Perhaps robots will follow the same path. Consider, for instance, the Nintendo (4820 150th Ave NE, PO Box 957, Redmond, WA 98052) *Entertainment System*. One of the hot gifts this past holiday season, that product is essentially a video game. However, several of the system's games made use of a limited robotic device. That device, called *ROB (Robotic Operating Buddy)* has a light-sensing system and limited gripping and lifting capability, but not much else. The robot is incapable of motion; it is mounted on a stationary base. Still for many it provides a first exposure to the world of robotics.

The state of the industry

For better or worse, that's the current state of the market. Of course, we may have missed one or two new or less-prominent manufacturers, but all of the main players have been represented here.

What can we look forward to next? Right now, things seem to be in a holding pattern. The philosophy of most of the manufacturers seems to be to pack as much hardware as they can in a box, and leave it to the public to put it to some type of use. As a result, most of the products announced or released in the past three years have not been widely accepted by the public.

For the most part, educational institutions have purchased the lion's share of the really sophisticated units, and consumers have bought the toy robots for their kids. Have any of those products advanced the state of personal robotics? The sad answer is no. None of the numerous applications we listed earlier are being addressed. University researchers will tell you that we are decades away from a robot that can clean house. With that attitude, it might take centuries to get a viable robot maid.

Then again, we are talking about a market that could be larger than the personal-computer market. That means that there are fortunes to be made here. Although things have been slow until now, it should take just one miracle to kick-start the robotics industry!

R-E

Building your own ROBOT

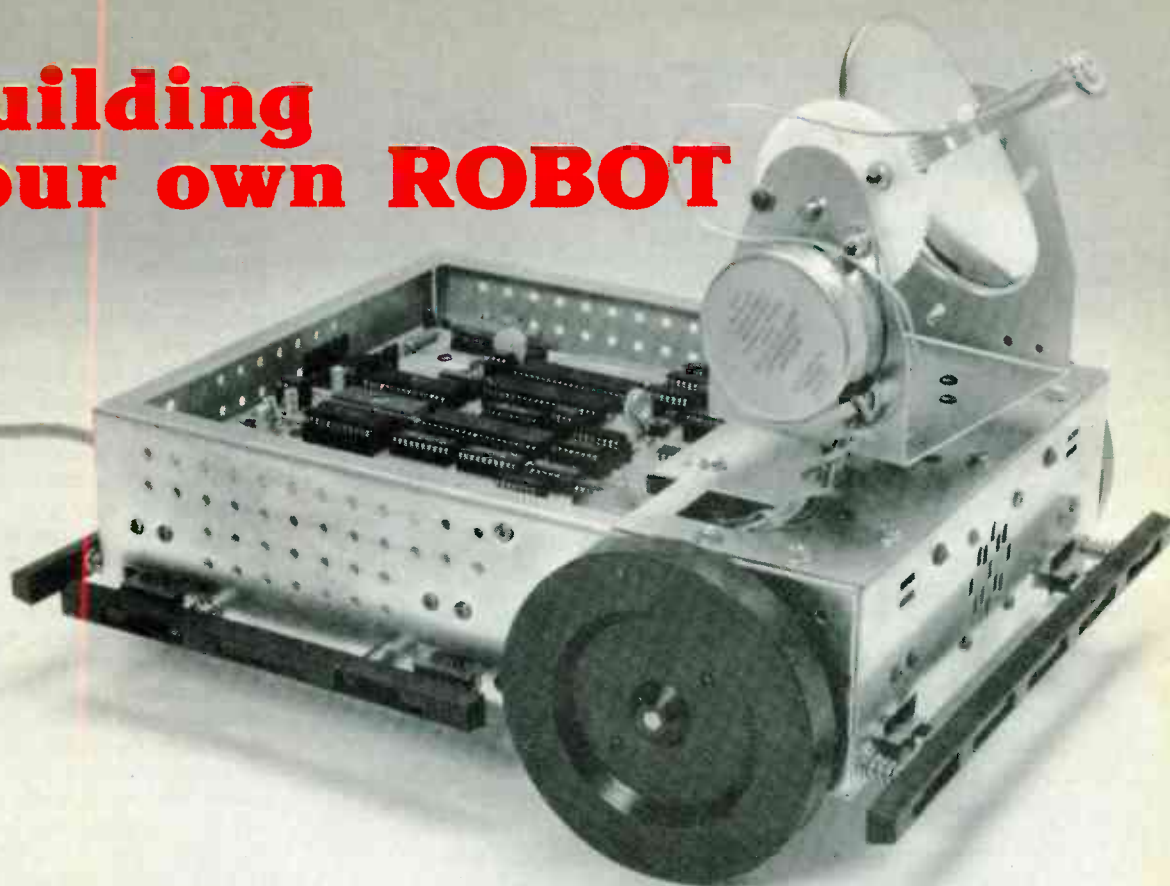

If you can't find the robot you are looking for, why not build it yourself?

Here are some pointers to help get you started.

MARK J. ROBILLARD

MUCH LIKE ARTISTS WHO TOIL WITH MESSY pastes to create their masterpieces, there are artisans who use the tools of technology to fashion their creations. In electronics, there is almost always a new art form to present a challenge to those creative minds. Three decades ago, two-way voice and code communications presented the challenge. Ten years ago it was the microcomputer that captured their fancy. Today, it's the robot.

Although experimenters were building robot-like machines decades ago, none could approach the sophistication of today's units. Several companies have begun offering both complete kits of parts for everything from robotic arms to complete computer-controlled robots. Because of the demand by hobbyists, many traditional electronics-parts suppliers are beginning to carry more robot-oriented supplies.

This article is for those of you who would like to try building your own robot. Here, we will attempt to tell you about the various components you might need, and, if possible, where they can be obtained.

Getting started

Whenever you are starting a new venture, it is useful to have some idea about what you are getting into. And, although you must have already had some exposure to the field for personal robots to interest you, there's always room for more knowledge. Thus, the best way to start is to get hold of as many good robotics books as you can.

There are a wealth of books available now. They range from the theoretical to the practical. Some of the better ones are listed in Table I.

One problem with such books is that the information they present can become out-of-date quickly. For more up-to-date information, you may want to consult one of the magazines that cover the field. At the present, there is only one periodical dedicated to the robot craftsman. *The Robot Experimenter* (174 Concord St., Suite 31, PO Box 458, Peterborough, NH 03458) was created to fill the void after *Robotics Age* (174 Concord St., Peterborough, NH 03458) began covering only industrial robotics. For those of you with

more than a passing knowledge of the field there are two professional journals that should be of interest. Those are the *International Journal of Robotic Research* (28 Carleton St., Cambridge, MA 02142) and the *Journal of Robotics Systems* (605 Third Ave., New York, NY 10157). Both report on the latest in robotics research throughout the world.

All about parts

If you are like most of us, about halfway through reading about robot construction, you'll develop an insatiable desire to begin tinkering. To keep yourself sane, you might want to have some basic robotic parts on hand for that moment.

When you think about robots, the first thing that should come to mind is motors. (You could also build a robot using pneumatics, but such a device would be out of place in the home.) Things are a lot easier now than they used to be. Just a few years ago, the overwhelming majority of the available hobby motors were simple three-volt types. On their own, those had negligible "pulling" power. To do any

TABLE 1—ROBOT BOOKS

How To Build A Computer-Controlled Robot

Tod Loofbourrow
Hayden Publishing
Rochelle Park, NJ 07662
\$7.95

Build Your Own Self-Programming Robot

David Heiserman
Tab Books
Blue Ridge Summit, PA 17214
\$10.25

Robotics Age: In The Beginning

Edited by Carl Helmers
Hayden Publishing
Rochelle Park, NJ 07662
\$19.95

The Complete Handbook of Robotics

Edward Safford
Tab Books
Blue Ridge Summit, PA 17214
\$11.50

Microprocessor-Based Robotics

Mark J. Robillard
Howard W. Sams Inc.
Indianapolis, IN 46268
\$16.95

Advanced Robot Systems

Mark J. Robillard
Howard W. Sams Inc.
Indianapolis, IN 46268
\$19.95

Basic Robotic Concepts

John Holland

Howard W. Sams Inc.
Indianapolis, IN 46268
\$19.95

How To Design And Build Your Own Custom Robot

David Heiserman
Tab Books
Blue Ridge Summit, PA 17214
\$13.50

Handbook Of Advanced Robotics

Edward Safford
Tab Books
Blue Ridge Summit, PA 17214
\$16.50

How to Build Your Own Robot Pet

Frank Dacosta
Tab Books
Blue Ridge Summit, PA 17214
\$8.95

Design And Application Of Small Standardized Components

Data Book 757, Volume 2
Stock Drive Products
Educational Products
PO Box 606
Mineola, NY 11501
\$7.95 (paperback)
\$12.95 (hardcover)

Apple II/Iie Robotic Arm Projects

John Blakenship
Prentice-Hall Inc.
Englewood Cliffs, NJ 07632
\$16.95

useful work, a complex gear-train assembly was needed. The cost was nearly a hundred times higher than that of the motor itself.

Fortunately, that has changed; it is now possible to purchase hobbyist motors that can actually do something. For those interested in experimenting with arms, the *Robotix 2000* building set from Milton Bradley (Springfield, MA 01101) is recommended. That kit contains four motors with integral gear trains, and a host of other structural pieces. Using the kit, it is possible to build a four-jointed arm, complete with gripper (supplied), in approximately five minutes. The motors are connected to manual control boxes via plug-in cables. It is also a simple matter to control those motors using a computer. To get some idea of how it can be done, see "Computer-Controlled Robot Arm," in the May 1985 issue of **Radio-Electronics**.

Another source for motors is H&R Corporation (401 E. Erie Ave., Philadelphia PA 19134). They have an impressive selection of some of the most powerful motors available to the hobbyist. Also impressive is the value you get for your money.

For some applications, you may find

that stepper motors are more useful than DC motors. Steppers provide you with a greater degree of control. There are two basic types of steppers that are appropriate for hobby experimentation—the four-phase unipolar stepper and the bipolar stepper; the former is more easily obtained.

Stepper motors carry supply-voltage and mechanical-power ratings. The power rating has to do with the amount of work the motor is capable of doing. A motor with a rating of 1-ounce-inch is capable of pulling a 1-ounce weight, located 1-inch away, about its shaft pivot. That is shown in Fig. 1.

The four-phase unipolar stepper motor

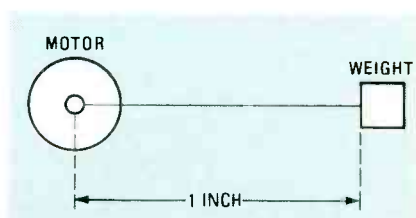

FIG. 1—THE AMOUNT OF WORK (torque) performed by a motor is equal to the weight to be lifted multiplied by the distance between that weight and the motor shaft.

is easy to control. Beside being able to interface them to microprocessor circuitry (through appropriate driver circuits), there are several sources of dedicated IC controllers for those motors. Basically, there are four separate windings and one or two common leads. The common is connected to a voltage source. To effect motion, one must supply a path for current to flow in each of the four windings by grounding their leads. The order in which the windings are energized determines the direction and the speed in which the motor turns.

Figure 2-a shows the basic hook-up scheme for a four-phase stepper. The transistors Q1-Q4 are the output stages of the driver circuitry. When a voltage is applied to the base of a transistor, it conducts, energizing the appropriate winding. Figure 2-b shows the timing sequence for those drivers for movement in either direction.

The bipolar stepper is connected in a different fashion. Its basic hook-up scheme is shown in Fig. 3-a. As you can see in that figure, there are only two windings. One side of each is connected to the power supply common. The other winding connections are used to direct the motor. Note that a bipolar power supply, ± 5 -volts in this case, is required for movement in both directions. Once again, the transistors are the output stage of the driver circuitry, and the timing sequence is shown in Fig. 3-b.

When would you use a bipolar motor over a unipolar type? For hobby robotics that decision really rests on the question of availability and price. If you have found a nice little stepper that has the torque required by your project, and it will run from the available supply voltages, then buy it. If you have questions about the hook-up required, most of the hobby suppliers will often send appropriate information along with the motor. Otherwise, many of the books listed in Table 1 provide information on how to hook up various motors.

Now that you've got the motors, you're going to need to mount them on something. Although it might sound archaic, one of the best building materials for robotics is wood. Wood is cheap, easily handled, and can be worked with using inexpensive tools. If you want your robot structure to look professional, simply paint it or finish it with plastic laminate.

Of course, wood comes in many grades, and some of those are not appropriate for this application. Regular lumber-yard-grade plywood is out. The voids in the middle of such woods make for a shabby appearance and drilling produces many splinters. For best results, stick with marine grade and special laminates.

Other items you will need include fasteners, support rods, and various mechan-

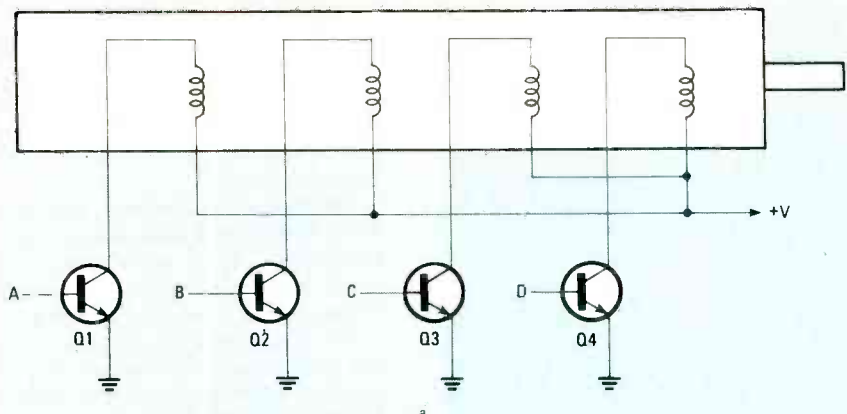

STEP	TRANSISTOR			
	Q1	Q2	Q3	Q4
1	ON	OFF	ON	OFF
2	ON	OFF	OFF	ON
3	OFF	ON	OFF	ON
4	OFF	ON	ON	OFF
5	ON	OFF	ON	OFF

FIG. 2—HOOKING UP a four-phase stepper motor. The table in *b* shows the order in which the transistors must be turned on to advance the motor in the clockwise direction.

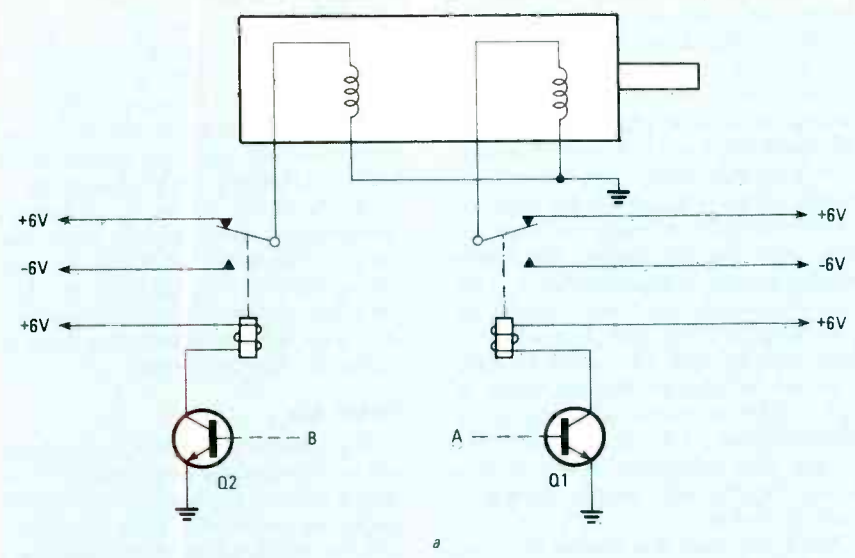

STEP	TRANSISTOR	
	Q2	Q1
1	OFF	OFF
2	ON	OFF
3	ON	ON
4	OFF	ON
5	OFF	OFF

FIG. 3—A BIPOLAR STEPPER is wired up in this manner. To advance the motor in the counterclockwise direction, reverse the turn-on sequence shown in *b*.

ical assemblies. The first place to look for those is a well-stocked hardware store. In fact any time you need wheels for robot carts, get the lawnmower type available in most stores. You can always get a replacement and they come in many sizes. The one standard feature of those wheels is that they all mount on half-inch diameter shafts.

To give you an idea of what can be accomplished with wood, take a look at Fig. 4. That "hand" has been built from wooden dowels and two pieces of thin aluminum. The motor that activates the gripping action is mounted in the middle palm region. The dowels are made of basswood and are available in almost all hobby shops. The aluminum was pur-

chased in the same shop. If you prefer to work in plastics, your local hobby shop is also a good source for styrene; that's the



FIG. 4—THIS ROBOT "HAND" was built almost entirely from wood.

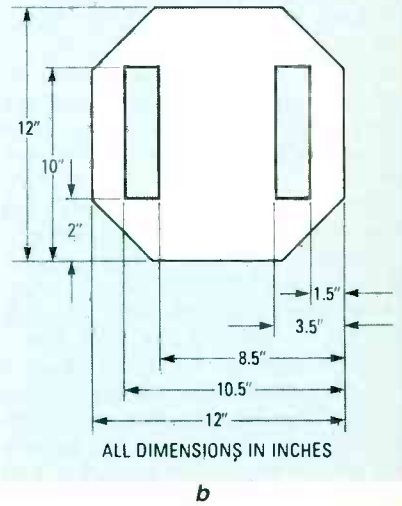
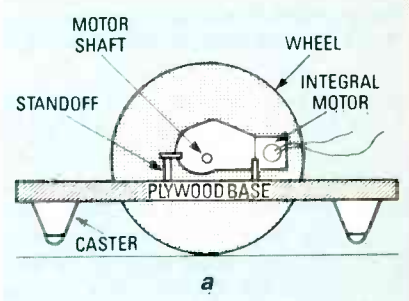

FIG. 5—A SIMPLE MOBILE BASE. A side view is shown in *a*; the top view in *b*.

material that's used to make airplane models.

Once you've got the motors and structural pieces on hand you can start tinkering. A two wheeled cart using two furniture casters for balance is a simple first project. The layout for a cart of that type is shown in Fig. 5.

Once you've built the cart itself, it's time to devise a control system. Your first effort should be to build a system to control the cart manually using a joystick. Hook up the switches in the joystick so that they control the motors to move the cart in the appropriate direction.

Once you get the basic operation of the cart down, it's time to add more functions. To do that, you'll need more parts. Gears

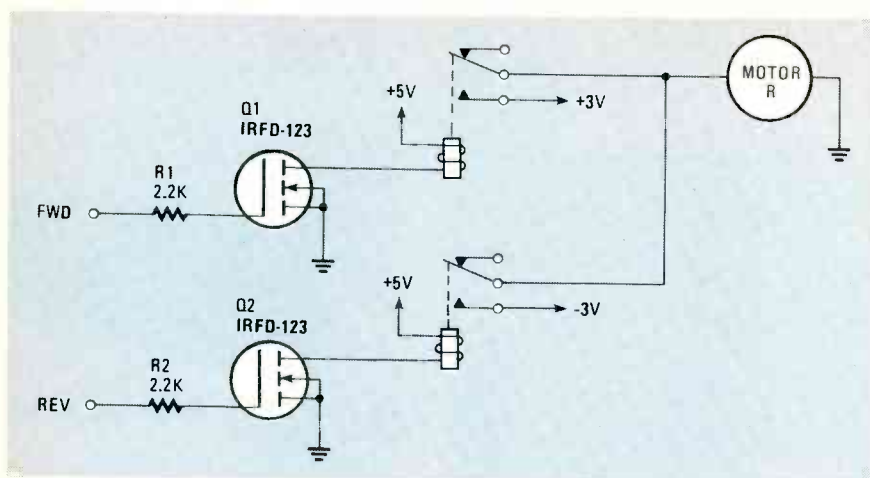

FIG. 6—WHEN USING AN ELECTRONIC circuit, such as a computer, to control motor operation, a simple transistor driver like the one shown here must be used.

are used to reduce the speed of a motor while increasing its torque. They can also be used to change the direction of a motor or to transmit the motor's rotational power into other types of movement. Finding gears that will mount onto the shaft of your particular motor may not be easy. Each motor has its own shaft size and hobby-grade motors tend to possess particularly small-diameter shafts. Most of the generally available gears and pulleys are made for much larger motors. For instance, you can get a number of gears from an automotive supply store, but the chances of them fitting your robot motor are slim.

We've thus far found two supply houses that sell gears in sizes, styles, and types appropriate for robot experimentation. Those are Stock Drive Products (55 South Denton Ave. New Hyde Park, NY 11040) and PIC Design (PO Box 1004, Benson Road, Middlebury, CT 06762). Both are very reputable vendors, and supply extensive catalogs for free. The cost of their parts, though, is not cheap. Yes, the material is high quality, but the cost of a few gears can set your project budget back a few years. I suggest using those suppliers when you absolutely need a particular gear or pulley and there is no other source.

In addition, one of the vendors, Stock Drive Products, has published a very complete manual on mechanical design for non-engineers. That book would be a valuable addition to any robot experimenters bookshelf. It is called the *Design and Application of Small Standardized Components Data Book 757*. It retails for \$7.95 in softcover and \$12.95 in hardcover. Among other things, the book contains a 51-page section on the mechanics of robots that contains information we have not seen published elsewhere.

Control

Because robots are supposed to move on their own, it will be necessary to develop some control circuits eventually. A

computer is not an absolute necessity, but one will make your robot capable of doing a whole lot more. Be that as it may, let's start with a less ambitious control system.

What parts are required to provide at least a minimum level of control? First of all, you're going to need relays if your motors are small DC types. Transistor motor-switches do work, but sometimes they do not provide full power to the motor. Small 5-volt SPDT relays do not take up much room, and are readily available from your local electronics supplier.

To drive those relays you've got to determine what will control the robot. If simple manually-activated switches are used, then you can connect the supply voltage directly through the switch to the relay. When other electronic circuits are controlling the relay, some form of power driver must be used. That can be a simple transistor switch like the one shown in Fig. 6. Each transistor is turned on by applying about 3 volts to the base via the resistor. That will cause current to flow through the relay coil, causing the relay's contacts to close.

When designing your control circuitry, you should keep power consumption in mind. While that might not be critical in the case of robotic arms, mobile units require battery-based on-board supplies. Because of that, use low-power technologies (CMOS, etc.) in your circuitry.

Power supply

Since we've already brought it up, now is as good a time as any to look into the types of power supplies that your robot might need. Once again: with robot arms or other stationary devices, don't worry about batteries; just use an adequate AC power supply. But when your robot must move around, then the only real choice is battery power.

What about the type of battery? Standard, non-rechargeable alkaline batteries can power a properly designed system for a surprisingly long time. For example, the

author has used two six-volt alkaline batteries in series to provide both a positive and negative supply that has powered six *Robotix* motors for about eleven months! Also, the same supply has been simultaneously powering a CMOS micro-processor circuit.

There are cases, however, that require much more current than alkaline batteries can provide. Those applications require use of lead-acid batteries. That is the type of battery that is used to power your car.

For robotic use, the lead-acid battery has one serious drawback (other than weight). Those batteries can leak corrosive acid if tipped. In some robot applications, that could prove disastrous. In fact, if you plan to use your robot in your home, you should seriously investigate other possible sources of power.

More appropriate are the newer types of lead-acid battery; in them, the acid is in the form of a gel. Obviously, those batteries are much less prone to leakage. Several suppliers offer many different types of those "gel-cells."

Lead-acid batteries are rated in amp-hours. For instance, if a battery is rated at 4 amp-hours, that means that a robot can draw 4 amps from the battery for one hour, or 1 amp from the battery for 4 hours.

All lead-acid batteries can be recharged. Recharging should be done in a well-ventilated area; the gasses emitted during recharging can be dangerous.

If you decide to go the rechargeable power-supply route, you may want to look into the possibility of having the robot charge himself. After all, were you using the robot for security, it would be unfortunate if the batteries were to run down just before the burglar arrives.

Robot kits

There are times when it really doesn't pay to do everything from scratch. If your goal is to learn to program robots, then it might pay you to take some shortcuts so that you can begin using the machine as soon as possible. Buying a pre-engineered kit takes all the worry out of the job. There are several good robots that come as kits. Aretec systems, manufacturers of the *Gemini* robot, sells that robot in kit form. They also will sell you, in kit form, the various subassemblies that make up the robot. Heath's *Hero* series is also sold in kit form, while Rhino Robot's *Scorpion* is only available in that form. And there are many others; for more information see "A Buyer's Guide to Personal Robots" elsewhere in this issue.

There is a lot of satisfaction that goes along with building your own robot. And though things may be a little tough now, this is a brand-new field. In the near future, there will be standard robot buses, standard mechanical interfaces, and even a standard programming language. It looks as if the fun is just beginning. R-E

STEREO TV Decoder



Are you still listening to TV in mono? Double your TV-listening pleasure with this stereo-TV decoder!

STEVE SOKOLOWSKI

STEREO SOUND—IT'S THE MOST EXCITING thing to happen to television since color! Now's the time for *you* to find out how exciting it can be. We explained what it is and how it works a year ago (in the February and March 1985 issues of **Radio-Electronics**). Now it's time to get your hands dirty. Our simple, one-IC circuit will double your viewing pleasure, yet it can be built for about the cost of a single pre-recorded videotape. But before we dive in to discuss circuit operation and construction, let's quickly review the basics of MTS (Multi-channel Television Sound) transmission.

Stereo-TV signals

As with standard FM-broadcast signals, the stereo-TV audio signal has three components. As shown in Fig. 1, they are: the pilot signal, left + right (L + R) audio, and left - right (L - R) audio. In a conventional TV receiver the L + R signal, or the *main channel* is the only one that is detected—it's the monaural signal that you normally hear through your TV's speaker. Note that it is a frequency-modulated (FM) signal with a 75- μ s pre-emphasis, and a bandwidth of about 15 kHz.

Just above the main channel is the *pilot* tone, which is used to alert the receiving circuitry that the L - R signal, or the *stereo-difference* subchannel is available for processing. The MTS pilot signal is 15.734 kHz—the standard TV horizontal-scanning frequency, f_H .

As you can see in Fig. 1, the L - R signal or *stereo subchannel* occupies the TV baseband frequency ranging from $2f_H$ to $3f_H$.

MTS allows for additional subchannels

that can be used for a number of purposes. One possible audio-baseband configuration is shown in Fig. 1. That configuration includes two additional subchannels: the SAP, or *Second Audio Program*, channel (which can be used for bilingual broadcasts and other program-related material) and the *professional channel* (which can be used for communicating with remote news crews, and other non-program-related purposes.) Our stereo adapter cannot decode any of those additional subchannels.

Stereo TV is generated in a manner quite similar to the manner in which broadcast FM is generated. As shown in Fig. 2, separate left and right audio inputs are applied, after low-pass filtering, to the matrix that provides the stereo sum (L + R) and difference (L - R) signals. The sum, or monophonic, signal gets the 75- μ s pre-emphasis; it is then clipped, filtered, and mixed with the difference

signal. Rather than pre-emphasis, the L - R signal is processed by the *dbx* compressor/noise-reduction system. (See the article mentioned above for information on how that system works.)

Those audio signals are then mixed with the 15.734-kHz pilot signal, which, as we said above, is derived from the horizontal sync. The resulting signal is filtered and then sent to the audio-modulation circuitry where it is modulated in the usual manner.

To receive stereo TV signals, all we really need is a circuit that will process that composite-audio signal in the converse manner. The basic idea is indicated in Fig. 3. The "TV detector" block separates the sum and difference channels, each of which is filtered (and expanded, if necessary). Then the L + R and L - R signals are applied to a matrix circuit that restores the original left and right channels. At that point they're ready for ampli-

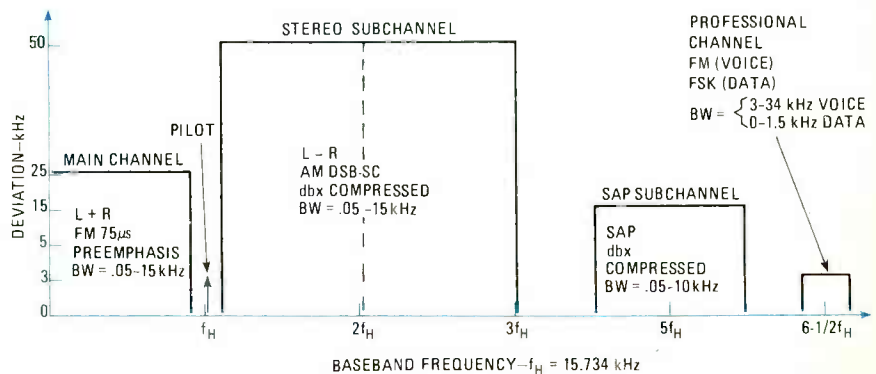
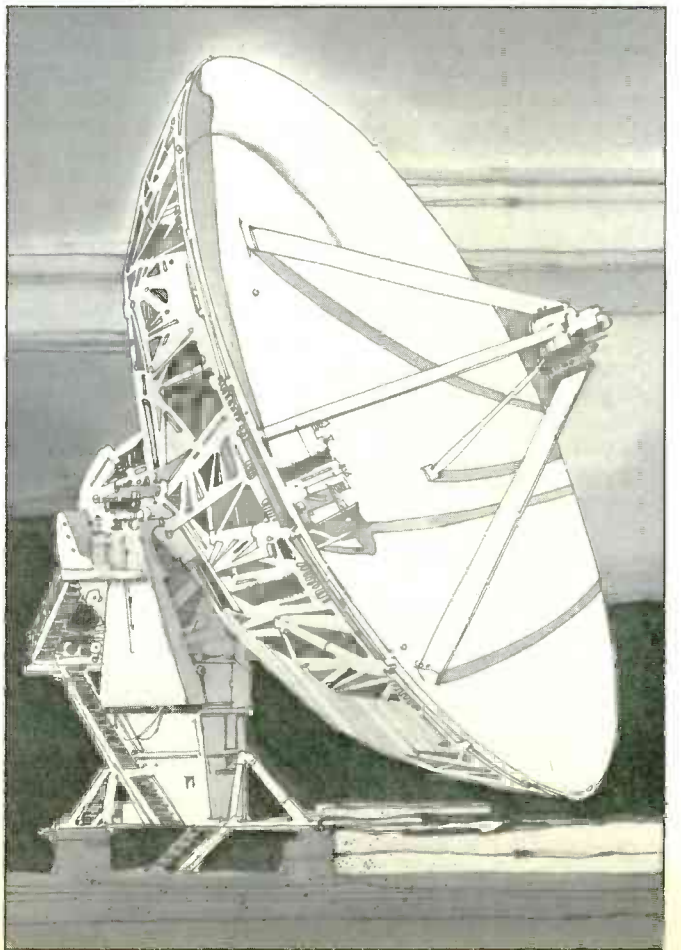
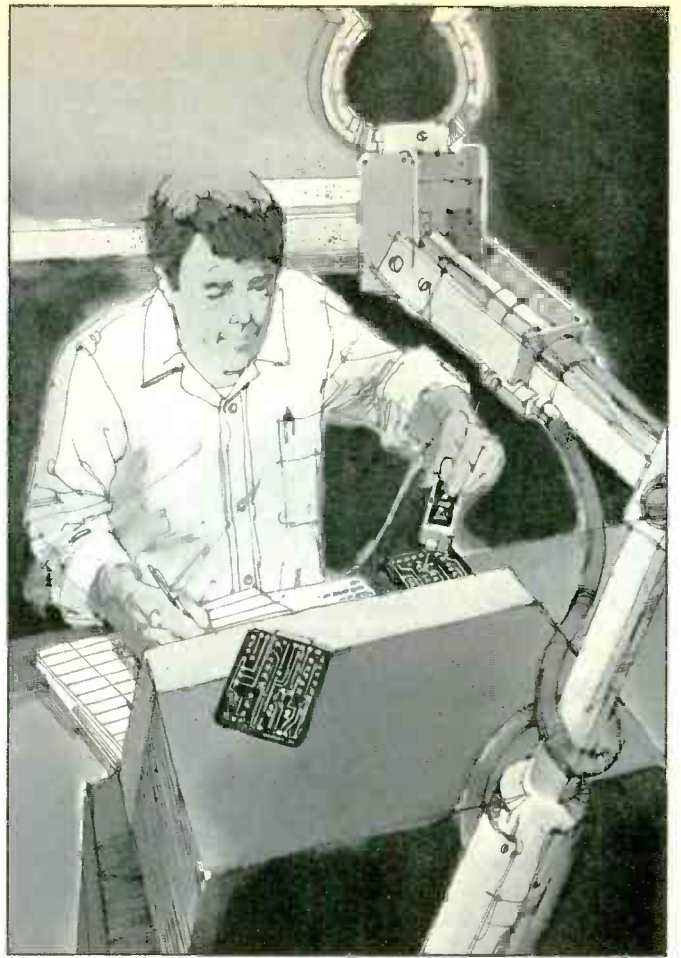

FIG. 1—THE MTS DISTRIBUTION OF SIGNALS provides for a monaural main channel, sub-channels for the stereo sub-carrier and a secondary audio program (SAP), and a professional channel for voice or computer (FSK) data.



CIE MAKES THE WORLD OF ELECTRONICS YOURS.

Today's world is the world of electronics. To be part of it, you need the right kind of training, the kind you get from Cleveland Institute of Electronics, the kind that can take you to a fast growing career in business, aerospace, medicine, science, government, communications, and more.

Specialized training.

You learn best from a specialist, and that's CIE. We're the leader in teaching electronics through independent study, we teach only electronics and we've been doing it for over 50 years. You can put that experience to work for you just like more than 25,000 CIE students are currently doing all around the world.

Practical training.

You learn best with practical training, so CIE's Auto-Programmed® lessons are designed to take you step-by-step, principle-by-principle. You also get valuable hands-on experience at every stage with sophisticated electronics tools CIE-designed for teaching. Our 4K RAM Microprocessor Training Laboratory, for example, trains you to work with a broad range of computers in a way that working with a single, stock computer simply can't.

Personalized training.

You learn best with flexible training, so we let you choose from a broad range of courses. You start

with what you know, a little or a lot, and you go wherever you want, as far as you want. With CIE, you can even earn your Associate in Applied Science Degree in Electronics Engineering Technology. Of course, you set your own pace, and, if you ever have questions or problems, our instructors are only a toll-free phone call away.

The first step is yours.

To find out more, mail in the coupon below. Or, if you prefer, call toll-free 1-800-321-2155 (in Ohio, 1-800-362-2105). We'll send you a copy of CIE's school catalog and a complete package of enrollment information. For your convenience, we'll try to have a representative contact you to answer your questions.

CIE Cleveland Institute of Electronics
1776 East 17th St., Cleveland, Ohio 44114

YES! I want to get started. Send me my CIE school catalog including details about the Associate Degree program.

Print Name _____

Address _____ Apt. _____

City _____ State _____ Zip _____

Age _____ Area Code/Phone No. _____ / _____

Check box for G.I. Bulletin on Educational Benefits

Veteran Active Duty **MAIL TODAY!**

OR CALL TOLL FREE

1-800-321-2155

(In Ohio, 1-800-362-2105)

RE-32

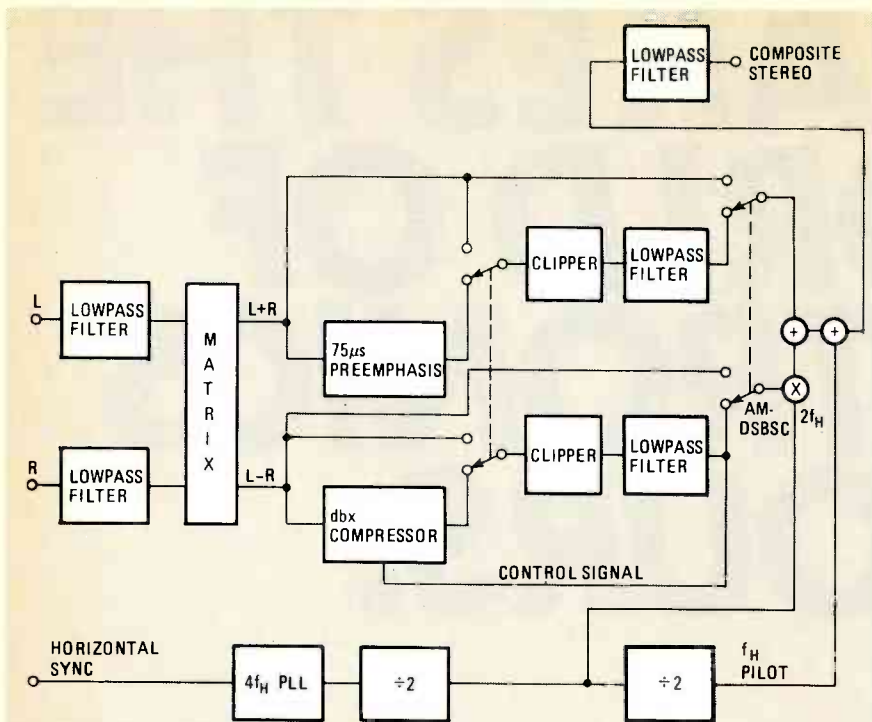

FIG. 2—MTS STEREO IS GENERATED in a manner similar to that of standard broadcast FM. MTS differs from broadcast FM in that it uses *dbx* noise-reduction, and the standard TV horizontal-scan frequency to generate the pilot tone.

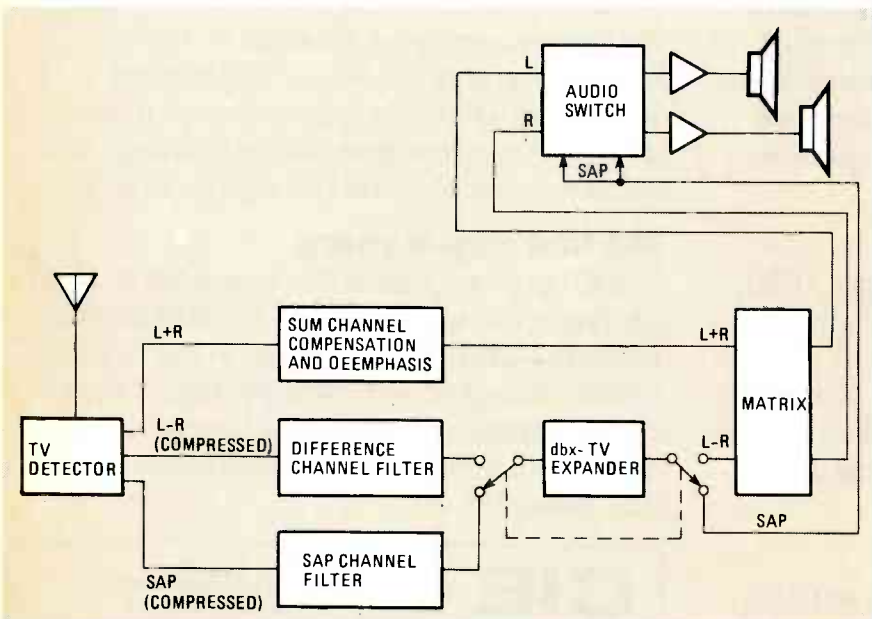

FIG. 3—THE ORIGINAL LEFT- AND RIGHT-CHANNEL AUDIO SIGNALS are recovered in the matrix decoder after filtering and de-emphasis of both L + R and L - R, and after expansion of the L - R signal by the *dbx* unit.

fication. (Note that the block diagram in Fig. 3 includes a SAP decoder, which our stereo adapter does not offer.)

If you're wondering how the original channels can be extracted from the sum and difference signals, examining the following equations should clear things up:

$$(L + R) + (L - R) = 2L$$

$$(L + R) - (L - R) = 2R$$

In other words, we can restore the left channel by adding the sum and difference

signals, and we can restore the right channel by subtracting the difference signal from the sum signal. At that point all we have to do, in order to provide usable stereo-TV signals, is provide power amplification. So how can we extract the left- and right-channel signals?

Circuit description

The schematic of the stereo-TV decoder is shown in Fig. 4. Assume for now that it is connected to a proper source of

composite audio. We'll show you how to do that in a minute.

The composite input signal is pre-amplified by transistor Q1 and is then coupled to the high-pass filter composed of C3, C4, R6, and R7. The filtered audio is then passed to IC1, an MC1310P "Coilless Stereo Demodulator." That IC is normally used to demodulate broadcast-band FM signals, but by changing the frequency of its on-board VCO (Voltage Controlled Oscillator) slightly (from 19 kHz to 15.734 kHz), we can use that IC to detect stereo-TV signals.

A block diagram of the MC1310P is shown in Fig. 5. Notice that the components connected to pin 14 control the VCO's frequency, hence the pilot-detect and carrier frequencies. For use in an FM receiver, the VCO would run at four times the 19-kHz pilot frequency (76 kHz), but for our application, it will run at four times the 15.734-kHz pilot frequency of stereo TV, or 62.936 kHz.

The MC1310P divides that master VCO signal by two in order to supply the 31.468 kHz carrier that is used to detect the L - R audio signal. The L - R signal undergoes normal FM detection, and at that point we've got two audio signals: L + R and L - R. The decoder block in the IC performs the addition and subtraction to produce the separate left and right signals.

Referring back to the schematic in Fig. 4, R10 and C10 form a de-emphasis network that compensates for the 75-µs pre-emphasis that the left channel underwent; R12 and C11 perform the same function for the right channel. Now we've completely restored the original audio signal—almost.

You'll recall, in Fig. 3, the *dbx* expander circuit. We have provided no *dbx* expansion because *dbx* IC's haven't been released for general distribution. (They're available only to licensed OEM's.) So to provide some noise reduction (which will be necessary if you live in a less-than-ideal reception area), what we can do is connect our adapter to a non-*dbx* noise-reduction system. Alternatively, we can connect our adapter to a stereo system with a built-in noise reduction system. (Another possibility would be to connect the stereo-TV decoder to the experimental compander discussed in the November, 1985 issue of *Radio-Electronics*—Editor.)

None of those solutions is perfect, so the stereo TV you'll receive is less than ideal. However, we'll get no stereo TV at all if we don't start building an adapter—so let's do it now!

Construction

Since we're not dealing with very high frequencies, the adapter can be built in just about any convenient manner. A PC board will simplify construction, though, so we've included a foil pattern in "PC

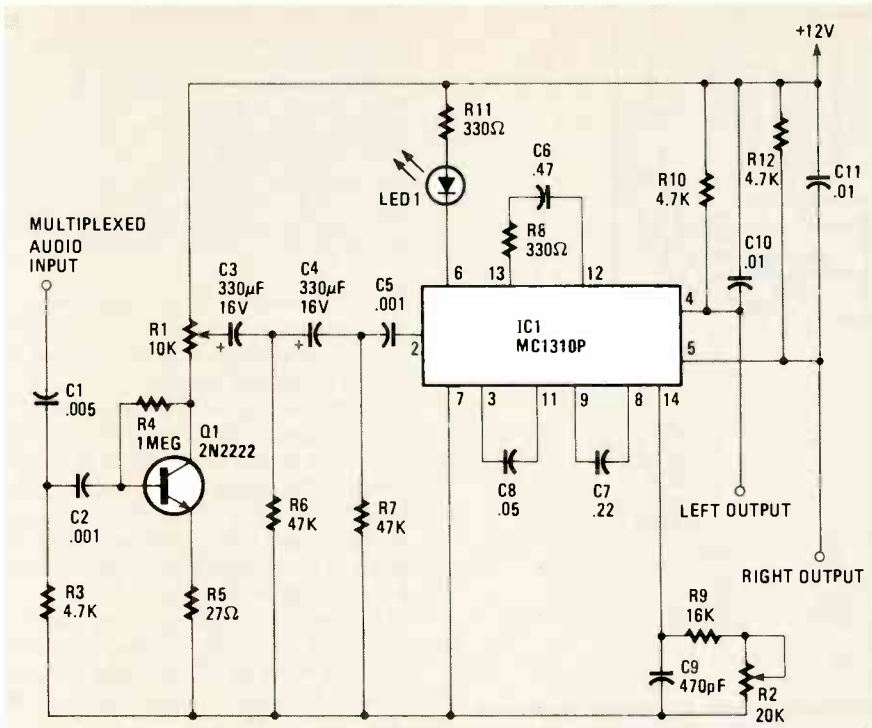

FIG. 4—THE CIRCUIT OF OUR MTS ADAPTER is quite simple, as shown here. The transistor provides a little pre-amplification for the IC (an MC1310P), which decodes the left and right audio channels.

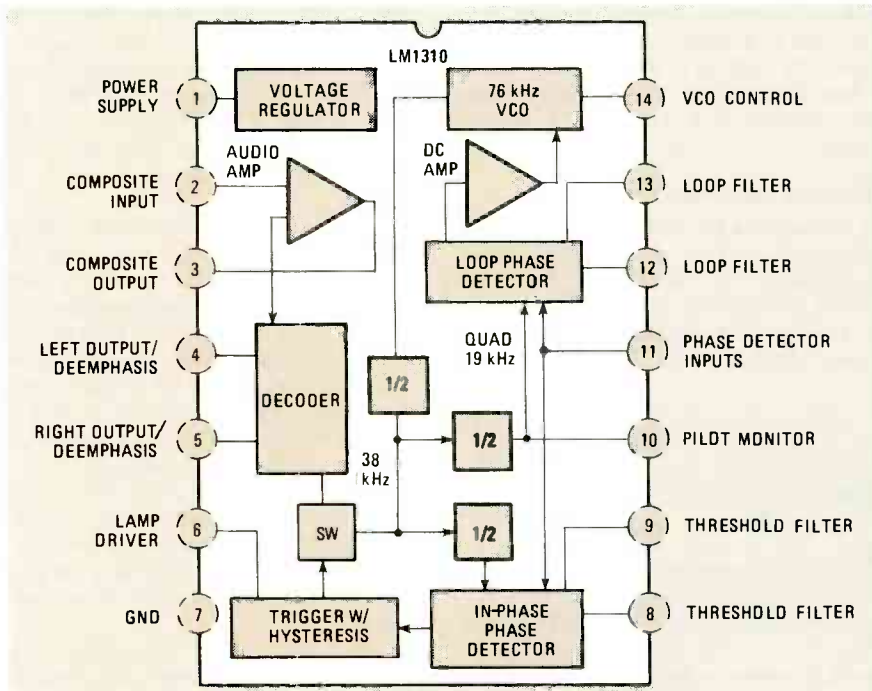

FIG. 5—THE MC1310P WAS DESIGNED FOR BROADCAST-FM decoding, but the stereo-TV pilot tone and carrier can be generated by altering the IC's VCO frequency from its nominal 76-kHz value.

Service." You can also buy a PC board and a kit of parts; see the Parts List for more information.

Use the parts-placement diagram in Fig. 6 and the photo in Fig. 7 as a guide for mounting all components. Use a socket for IC1. Be sure to orient Q1 correctly, and don't apply too much heat to the transistor.

In Fig. 7 you'll notice a small board to

the right of the main PC board. That's a 7812 regulator circuit that supplies 12-volts DC for the circuit. The schematic of that circuit is shown in Fig. 8. The foil pattern for the power-supply board is also shown in "PC Service," and the parts-placement diagram is shown in Fig. 9. For our prototype, we used a small wall-mount transformer to supply AC to the power supply.

PARTS LIST—MAIN BOARD

All resistors 1/4-watt, 5% unless otherwise noted.

- R1—10,000 ohms, audio taper, PC-mount, trimmer potentiometer
- R2—20,000 ohms, linear taper, PC-mount, trimmer potentiometer
- R3, R10, R12—4,700 ohms
- R4—1 megohm
- R5—27 ohms
- R6, R7—47,000 ohms
- R8, R11—330 ohms
- R9—16,000 ohms

Capacitors

- C1—0.005 μ F, ceramic disc
- C2, C5—0.001 μ F, ceramic disc
- C3, C4—330 μ F, 16 volts, electrolytic
- C6—0.47 μ F, ceramic disc
- C7—0.22 μ F, ceramic disc
- C8—0.05 μ F, ceramic disc
- C9—470 pF, ceramic disc
- C10, C11—0.01 μ F, ceramic disc

Semiconductors

- IC1—MC1310P or LM1310 or XR1310 "Inductor-less" FM stereo demodulator
- Q1—2N2222
- LED1—Standard red LED

Note: A kit containing the main PC board and all parts that mount on it is available for \$30.00 plus \$1.50 for shipping and handling. Order from Del-Phone Industries, Inc., P. O. Box 150, Elmont, NY 11003. New York residents must add applicable sales tax.

When you've got the PC boards assembled, check them over carefully for solder bridges between adjacent pads and traces on the PC board. And make sure that all polarized components—IC1, Q1, LED1, the electrolytic capacitors—are installed correctly. When everything looks OK, it's time to align and install the adapter.

Alignment

You'll need an audio oscillator and a frequency counter to align the adapter. Connect the frequency counter to the oscillator and adjust the oscillator for a frequency of exactly 15.734 kHz at about 1/2-volt p-p. Then connect the output of the oscillator to the input of the adapter, and apply power. Adjust trimmer potentiometer R1 to its center position, then adjust trimmer potentiometer R2 until LED1 illuminates. If you have trouble getting the LED to light up, adjust R1 to allow more signal to get through to IC1.

If you don't have an audio oscillator and a frequency counter, you can align the adapter by connecting your adapter to a source of composite TV audio, as described below, and then tuning in a local station that you know is broadcasting in stereo. With the adapter connected to your stereo system, and R1 set in the center of its range, slowly adjust R2. Watch for the LED to light up, and then adjust R1 and R2 for best received audio.

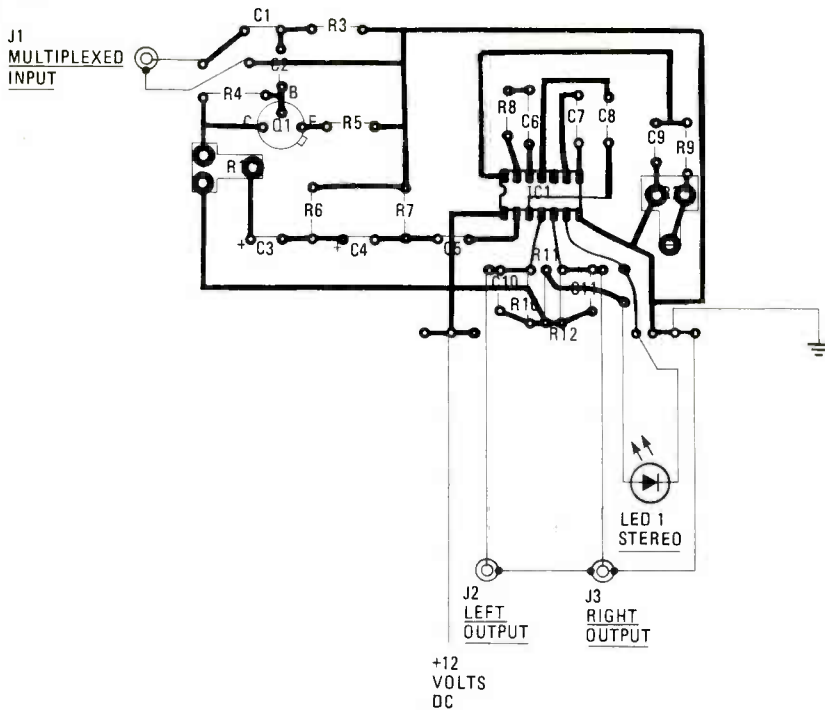

FIG. 6—THE STEREO-TV DECODER'S COMPONENTS are located on the PC board as shown here.

- PARTS LIST—POWER-SUPPLY**
 IC1—7812 12-volt, 1-amp regulator
 D1—D4—1N4001 power rectifier
 C1—2200 μ F, 25 volts, electrolytic
 C2—0.1 μ F, monolithic
Other components
 F1— $\frac{1}{4}$ -amp, 250 volts
 J1, J2, J3—RCA phono jack
 S1—SPST, miniature toggle
 T1—12-18-volt wall-mount transformer

First, there will be too much distortion—you have to pick up a low-level signal. Second, the output will not contain the proper composite signal.

VCR connection—You may simply be able to connect the adapter to the audio output on the back of your VCR. Unfortunately, the adapter will not operate correctly with most VCR's because many manufacturers filter out the necessary signals and leave only the main channel. But it's certainly worth a try.

External-TV connection—If you purchased a TV recently, you may be in luck. If your TV has an stereo output jack, just connect the input of your adapter to that jack.

Internal-TV connection—**Warning**—Don't attempt this sort of connection unless you are sure you know what you are doing and you have complete documentation for your TV. The high voltages in your TV are hazardous to your health, and the health of your adapter! Remove the back of your TV and solder a shielded cable to the output of your set's audio detector. Connect the other end to the adapter.

Internal-VCR connection—**Warning**—Don't attempt this sort of connection unless you are sure you know what you are doing and you have complete documentation for your VCR. One mistake could be very expensive! As with the previous method, locate the audio detector IC. Then solder one end of a shielded cable to that point. Connect the other end to the audio input of the adapter.

Radio connection—If you have a table or portable radio that can receive TV audio, carefully connect one end of a shielded cable to the audio detector's output. Connect the other end to the adapter's input.

Whichever method of installation you choose, connect the outputs of the adapter to your stereo amplifier's (or receiver's) auxiliary inputs and fine-tune the alignment.

Conclusions

Stereo TV is still new, so even though many programs are now recorded in stereo (such as *Johnny Carson* and *Miami Vice*), not all stations are equipped to broadcast stereo audio. For a partial listing, check the back issues of **Radio-Electronics** mentioned above, or call your local TV stations.

R-E

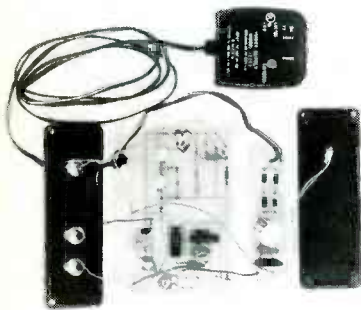

FIG. 7—YOUR STEREO-TV DECODER'S PC BOARD should look like this after all components are mounted.

That completes alignment! What we did was simulate the 15.734-kHz pilot signal with the audio oscillator. When the adapter is properly connected to a VCR or TV that is receiving a stereo signal, the LED will light up to indicate that a stereo signal is being received—just as the STEREO indicator on a standard FM receiver does.

Adapter installation

Connecting the adapter to a source of composite audio is potentially the most difficult part of this project. We'll describe five different possibilities.

Don't get any ideas about using the ear-plug output of your TV, VCR, or radio.

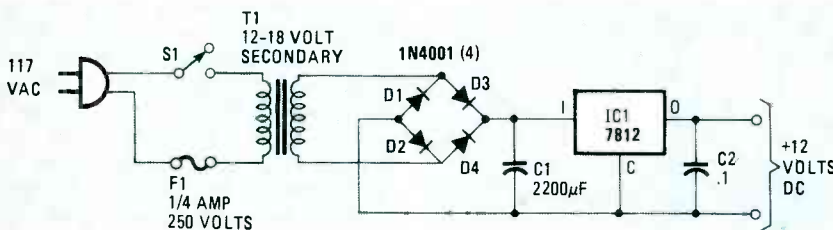

FIG. 8—THIS POWER SUPPLY provides plenty of power for the stereo-TV decoder.

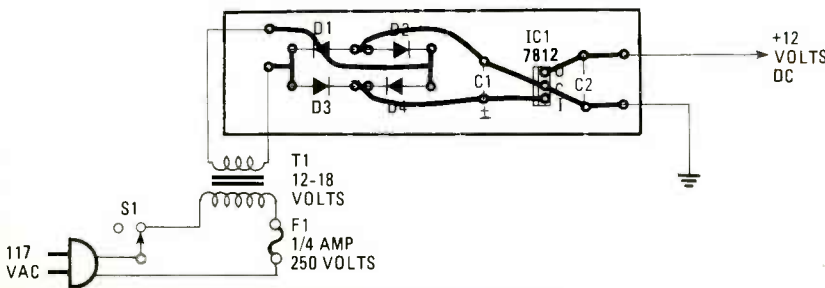

FIG. 9—PARTS PLACEMENT diagram for the power supply board.

BUILD THIS



Walkman

AMPLIFIER

Build this versatile amplifier and get "home stereo" sound from your Walkman-type cassette player or radio. It has many other applications, too!

PORTABLE WALKMAN-TYPE STEREO CASSETTE players and radios are great for entertainment on the go, but sometimes it would be nice if they could be used to give full stereo sound—like a home hi-fi. Well, when used with the small, high-performance stereo amplifier described in this article, those units are capable of doing just that. In addition, thanks to the inclusion of a pair of preamplifier stages, the amplifier can be used with low-level inputs such as microphones, turntables, and electric guitars. It can even be wired up as a tiny PA system.

About the circuit

Figure 1 shows the schematic for the basic *Walkman* amplifier. It is designed around a National LM380 audio power amplifier IC. The gain of that low-cost IC is internally fixed so that it is not less than 34 dB (50 times). A unique input stage allows input signals to be referenced to ground. The output is automatically self centering to one half the supply voltage. The output is also short-circuit proof with internal thermal limiting.

With a power supply between 9 and 15 volts, and a minimum 8-ohm load, a heat sink is generally not required for the design shown. If you choose to build the circuit using the PC board shown in our

PC Service section, a very small amount of heat sinking is provided by that board's design; the copper tracks act as thermal fins. Although that does not normally represent enough heat sinking if the IC is to be extended to its maximum capability, with this design and the limited parameters that the circuit operates within, that heat-dissipation scheme should prove sufficient. With a maximum supply of 15 volts and an 8-ohm load, the output is around 1.5-watts-per-channel. The input stage is usable with signals from 50-mV to 500-mV rms.

If the amplifier is to be used with a source other than a personal stereo, such as a phonograph or an electric guitar, some type of preamplifier is required. A suitable circuit is shown in Fig. 2. In that circuit, two 741 op-amps have been configured as input amplifiers. Their input stages have been referenced to a common point—half the supply voltage. That voltage is derived from a voltage divider made up of R1 and R2, two 2.2K resistors. The gain of each of the 741's has been fixed at 21 by the input resistors (R3, R4) and the feedback resistors (R9, R10). Input capacitors, C1 and C2, are used to filter out any DC component from the input signal.

With a power supply of 12 volts, the quiescent current drawn by the total system is 30 to 35 mA. Under driven conditions, the drain could increase to 300 mA or more.

Building the amplifier

While the circuit can be built using any construction technique, we recommend using a PC board. A suitable design is shown in our PC Service section (elsewhere in this magazine). The parts-placement diagram for that board is shown in Fig. 3. Note that the board has been designed to accommodate both the power amplifier of Fig. 1 and the preamplifier of Fig. 2. All inputs and outputs of both amplifier stages have been made accessible for maximum flexibility.

As with any project, the first step is to make sure that you have all of the parts on hand. One source for a complete kit of parts is given in the Parts List. Otherwise, you should be able to get most, if not all, of the parts from your favorite distributor.

Begin construction by installing all of the resistors, excluding the two potentiometers. Next, install the IC's. We realize that that order of construction is a bit unconventional, but because of the large size of the electrolytics that flank some of the IC's, it is easier to perform the steps in that sequence.

Once the IC's are in place, the capacitors should be installed. Be sure to note the polarity of the electrolytics and install them correctly.

The only connections left are the volume controls, R15 and R16, the input wiring, and the connection to the power supply. The potentiometers are panel-

*Adapted from a story that originally appeared in Dick Smith's "Fun ways into Electronics, Volume Three."

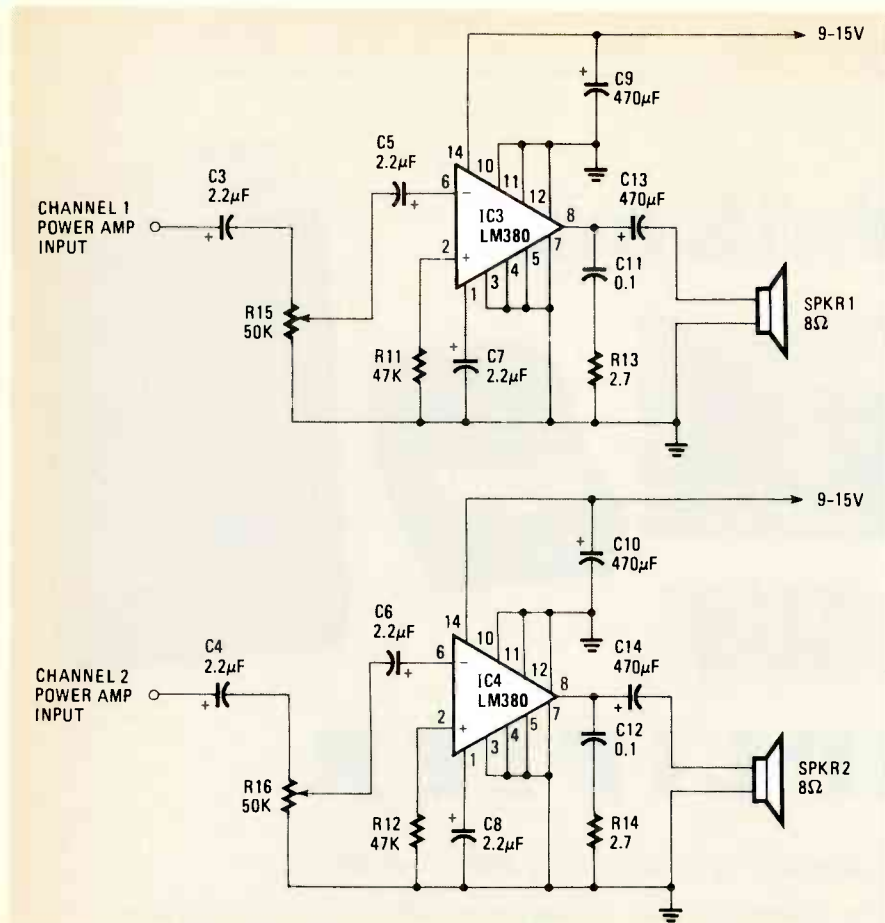

FIG. 1—THE WALKMAN AMPLIFIER. With this simple circuit you can use your personal stereo to drive standard 8-ohm speakers.

mount units; they are mounted on the front panel of whatever case you house the circuit in, and they are connected to the board via jumpers.

The input wiring scheme is dictated by how you use the system. If you are using the amplifier with a *Walkman*-type stereo to drive a pair of 8-ohm speakers, only the power amplifier stage is used. If the input is a microphone, turntable, etc., the pre-amplifier stage will also need to be used. We'll look at the appropriate wiring schemes in more detail when we discuss the various applications for the amplifier.

Once you've checked your work for accuracy, and you're satisfied that there are no solder bridges, etc., on the board, power can be applied to the circuit. The unit requires at least 9 volts at 200 mA, and will work with power supplies of as high as 12 volts. Obviously, using a 12-volt supply will result in higher levels of audio output. Suitable power supplies are available from a number of sources, including the one mentioned in the Parts List.

Using the amplifier

Normally, those miniature *Walkman*-type personal stereos can only be used with headphones. But if the power amplifier stage of the circuit is used, 8-ohm

speakers can be driven from those units.

Figure 4 shows the input wiring scheme that is followed when the unit is used as a

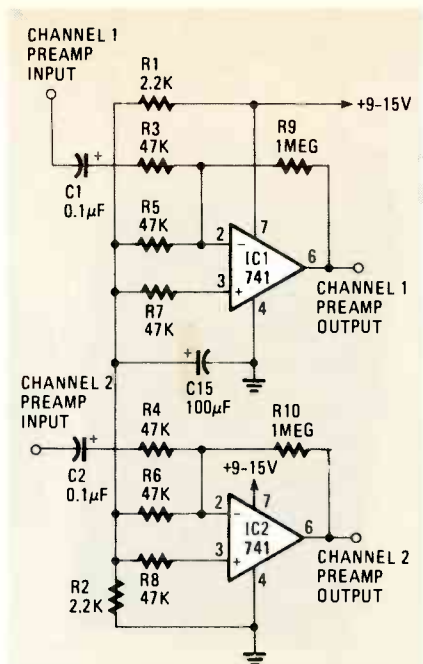

FIG. 2—THE PREAMP. If you wish to amplify low-level signals, such as the output of a turntable, the signal will first have to be fed to the preamp shown here.

personal-stereo amplifier. Note that only the power-amp stage is used; no connections are made to the preamp.

The amplifier is connected to the personal stereo via the stereo's headphone jack. Thus, the input to the amplifier must be connected to a miniature stereo phono plug as shown. Note the two 33-ohm resistors connected across each channel. Personal-stereo outputs are designed to feed headphones, not amplifier/speaker

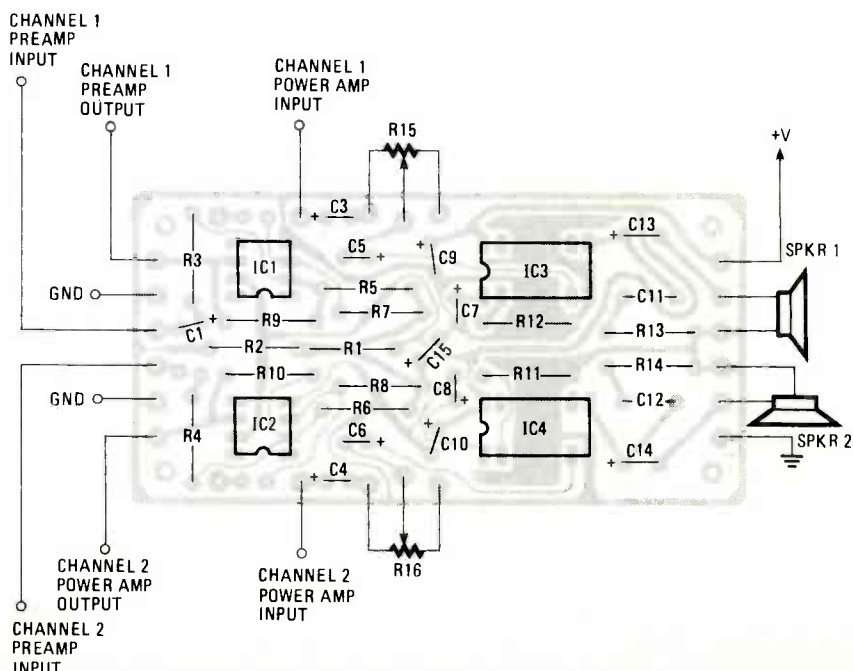

FIG. 3—PARTS-PLACEMENT DIAGRAM. Both the power amp and the preamp circuits are contained on this board.

combinations. Thus, those resistors are included in the input for impedance matching. Alternately, if the stereo has two headphone output sockets, as most do, you can leave one set of phones connected to the unit. Then, the 33-ohm resistors are not necessary.

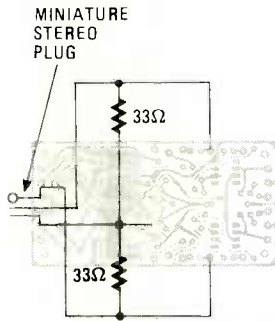

FIG. 4—USE THIS INPUT WIRING SCHEME when using the circuit to amplify the signal from a personal stereo. The 33-ohm resistors are used for impedance matching with the personal stereo's headphone output.

If the input is to be a microphone, turntable, or any other low-level source, the preamplifier stage must be used. In that case, the signal source is input to the preamplifier, and the output of the preamplifier is fed to the power amp. If that is done, input signals ranging from 3.5-mV rms to 100-mV rms can be accepted.

By using the twin output stages in a

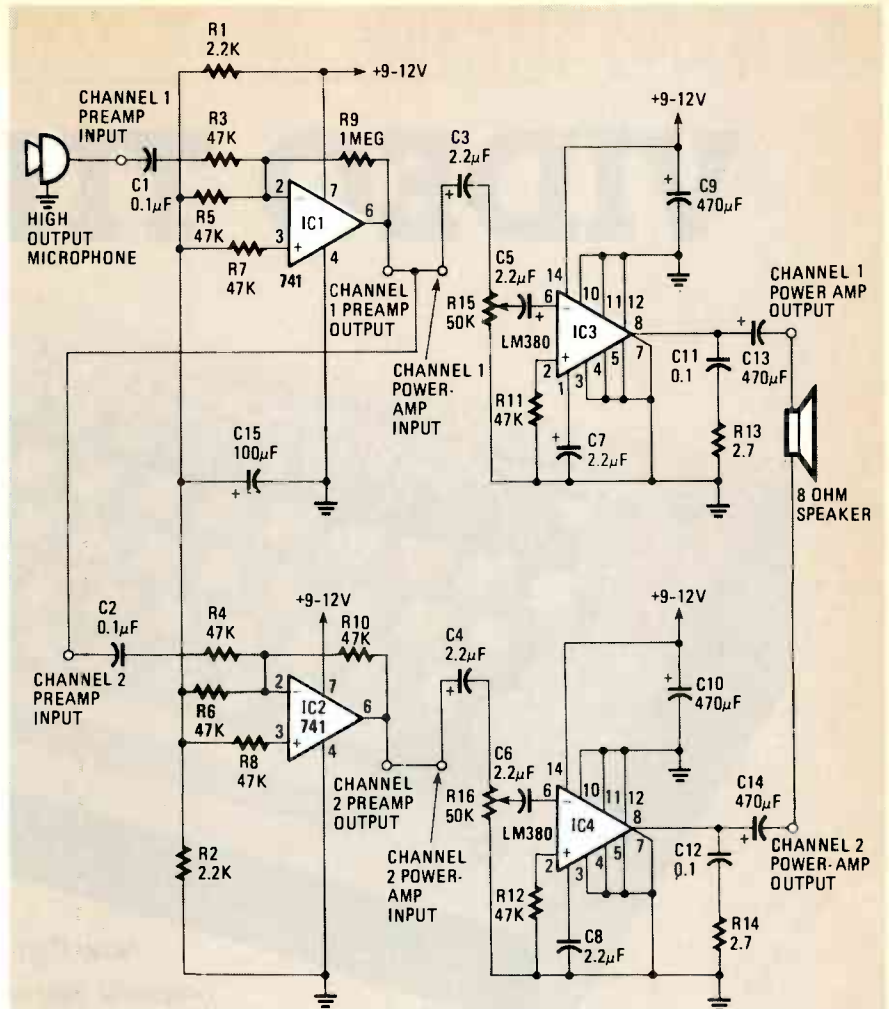

FIG. 5—THE CIRCUIT can be used as a small PA amplifier if it is wired up as shown here. The output of this circuit will be about 3-watts.

PARTS LIST

All resistors ¼ watt, 10%, unless otherwise noted

- R1, R2—2200 ohms
- R3—R8, R11, R12—47,000 ohms
- R9, R10—1 Megohm
- R13, R14—2.7 ohms
- R15, R16—50,000 ohms, potentiometers, audio taper

Capacitors

- C1, C2—0.1 μ F, 16 volts, tantalum
- C3—C8—2.2 μ F, 16 volts, electrolytic
- C9, C10, C13, C14—470 μ F, 16 volts, electrolytic
- C11, C12—0.1 μ F, ceramic disc
- C15—100 μ F, 16 volts, electrolytic

Semiconductors

- IC1, IC2—741 op-amp
- IC3, IC4—LM380 audio amplifier

Miscellaneous: PC board, speaker, hook-up wire, etc.

The following is available from Dick Smith Electronics, Inc., PO Box 8021, Redwood City, CA 94063: Kit of all components, including PC board, but excluding speakers and power supply (K-2667) \$14.95 plus \$3.00 shipping. A 12V, 500 mA power supply (M-9555) is available for \$6.95, plus \$3 shipping (\$1 if ordered with the amp. California residents must add 6.5% sales tax. Orders outside U.S. must remit U.S. funds and include \$5 for shipping.

“bridge” mode, the output power can be approximately doubled (to 3 watts). If that is done, the circuit can be used as a mini PA amplifier.

To use the circuit for such an application, the speaker is connected across the active output points of each amplifier as shown in Fig. 5. Let's look at that circuit in a little more detail.

In that circuit, the channel-1 preamp is used as an input stage with a gain of 21; it can accept inputs ranging from 3.5 to 100 mV. The channel-2 preamp, however, has been modified (compare the circuit to the one shown in Fig. 2). Now, the gain of that stage has been reduced to unity by changing the feedback resistor, R10, to 47K. That stage now acts as an inverter. That satisfies the requirements of the bridge output; that is, one input is positive-going while the other is negative-going. In other words, the inputs to the output (power amp) stages are 180 degrees out of phase. That provides twice the voltage swing across the 8-ohm load for a given supply, thereby increasing the output power by a factor of four over that of a single stage.

The key factor limiting the amount of power that that circuit can deliver to the

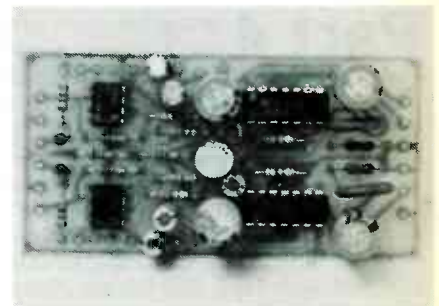

FIG. 6—FOUR IC's comprise this simple, yet versatile amplifier. A single-channel amp with double-power output can be configured.

load is power dissipation. Because of that, we have limited the power supply to a maximum of 12 volts. That, as previously stated, will result in a maximum power output of about 3-watts rms. To obtain more power you could attach a heatsink bent from a piece of copper 1.5" on a side. Bend two wings up at a 30° angle, leaving a ¼-inch strip down the center. Glue the center—wings up—to the output IC's with epoxy.

Note that in the dual configuration, both volume controls need to be adjusted equally to control the output. R-E

VIDEO TITLER



JACK FLACK

Now that you have your video titler working properly, you can make it even more versatile by interfacing it with a home computer.

Part 4 WHEN WE LEFT OFF last time, we promised that we'd look at the software that controls the video titler. So we'll start off with an overview of the titler's operating system, and then we'll look at how you can interface the titler with several popular home computers. Since we'll be referring back to things we described in the previous three installments (November and December 1985, and January 1986), you might want to have them on hand.

The titler's software, which is contained in IC19, a 8K × 8 EPROM, basically performs three functions: It initializes the video-display processor (VDP), it polls the keyboard, and it manipulates the VDP and the video RAM in response to keyboard inputs. Figure 18 is a flowchart of the operating system that fills in some of the details. If you'd like an even closer look at the software, a source listing is available for a nominal fee. See the Parts List for more details.

One of the best features of the video titler is its versatility. For example, you can even change its character font by burning a new EPROM. We'll be the first to admit that burning a new EPROM is not

the easiest way to change a font—especially if you don't have an EPROM burner. Fortunately, there's an easier solution: Interface the titler with another computer.

Why interface?

It might seem strange to go through all the trouble to design a special video-titler computer and then turn off its microprocessor so that it can become another computer's peripheral device. It's really not that strange, though.

Interfacing the titler with a home computer lets us take advantage of all the advanced features available on the computer for the cost of a simple interface adapter. And when you consider how the prices of home computers have dropped, it begins to make a lot of sense. When you realize that interfacing a computer to the titler will let you create and superimpose sophisticated animation, interfacing the titler to a computer begins to make even more sense.

The interface circuit

Figure 19 shows the pinout of the video titler's expansion/interface port, and Fig.

20 is a schematic of the interface circuit for four popular computers: the IBM PC, Apple II, Commodore 64, and TRS-80 Color Computer. Other computers can be interfaced with the titler as long as you have similar signals available on the expansion port.

The main functions of the interface circuit are to buffer the titler's data and address lines and to provide compatible connectors for each computer. But even more important, the interface circuit allows the VDP to be mapped into the host computer's memory (or I/O) address space so that the host computer can access the VDP's registers and the video RAM by using PEEK and POKE commands (or OUT and INP commands in an IBM PC.)

Unfortunately, we don't have the space here to discuss all the signals used in the interface circuit. You can consult the literature available on your particular computer for more information on the bus signals used in the interface. However, if you're not interested, rest assured that if you follow the interface schematic, and use all the correct addresses in your programs, you don't really need to understand all of the theory.

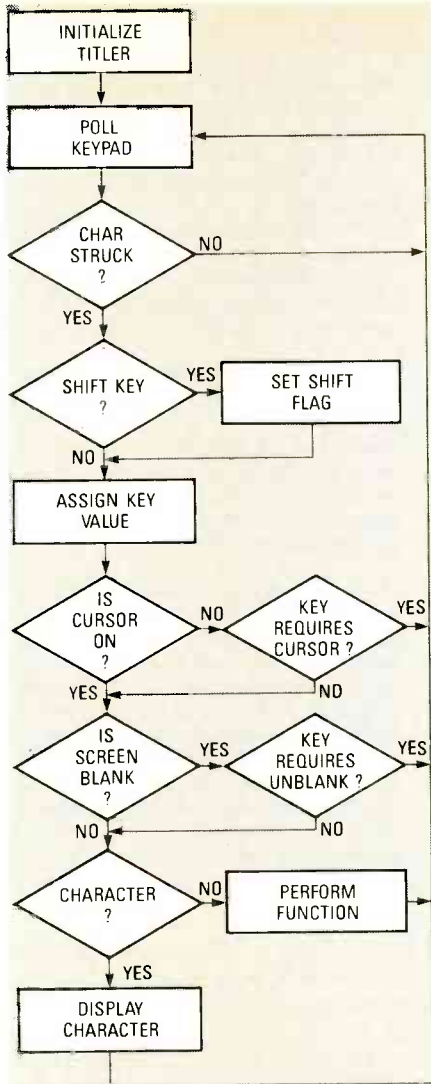

FIG. 18—THE OPERATING SYSTEM of the titler has three basic functions. It initializes the VDP, polls the keyboard, and responds to the keyboard inputs.

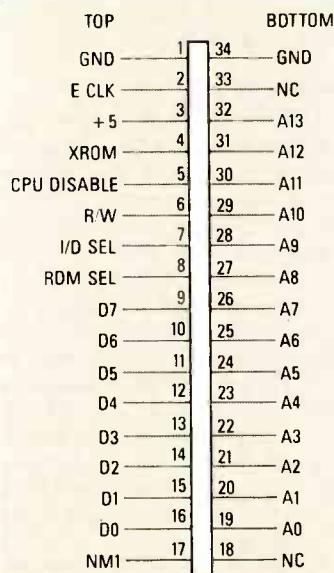

FIG. 19—THE EXPANSION-PORT PINOUT. A 34-conductor ribbon cable is the best way to connect to the card edge.

Building the interface

The interface is considerably easier to build than the titler, but there are several points worth mentioning. While you can build the interface circuit on a prototyping board, custom circuit boards are being developed by the supplier of the video titler's main board. (See the Parts List.) We suggest you contact them for information on price and availability.

If you use a prototyping board, be careful when you route the power-supply connections. If you accidentally route +12, -5, or -12 volts back through one of the titler's bus lines, you're almost certain to lose a few IC's. Carefully check for shorts on the card edge with an ohmmeter. If you use a ribbon cable to connect the interface board to the titler, be sure to mark the top side of the connector to remind you not to plug it in upside down.

When you have the interface circuit complete and you're ready to try it out, remember these rules: Always turn off the computer and the titler before plugging the cards and cables in. And when you power up, always turn the titler on first!

The VDP

Before we start controlling the titler with a host computer, we have to study what we're really going to control: the VDP. The interface allows the VDP to be mapped into the memory (or I/O) address space of the host computer. You can then write BASIC programs to access the VDP's registers and the video RAM by using PEEK and POKE commands (or OUT and INP in an IBM PC.)

The VDP is an extremely versatile device that provides a number of features that make it easy to create and manipulate screen images. The VDP is also an extremely complex device: if you plan to do any serious work, you'll want to get your hands on Texas Instruments' *Video Display Processors Programmers Guide* (TI No. SPPU004), which is available from Texas Instruments, P.O. Box 809066, Dallas, TX 75380-9066.

Figure 21 shows how the VDP image is made up of 35 separate planes: 32 *sprite planes*, a *pattern plane*, a *backdrop*, an *external video plane*, and a *black plane*.

The planes are arranged into priorities so that images appearing on the lowest-numbered plane will show on the screen. In other words, when two or more planes contain images at the same place on the screen, the plane with the highest priority is displayed. That makes it easy to simulate 3-D effects, where objects appear to move in front of other objects or images. The "0" sprite plane has the highest priority, the "1" sprite plane has the second highest, etc. The external-video plane has the lowest priority.

VDP modes

The VDP can operate in four modes:

PARTS LIST

Capacitors

C1—10 μ F, 50 volts, electrolytic
C2—C5—0.1 μ F, ceramic disc

Semiconductors

IC1—74LS245 octal 3-state driver
IC2—74LS367 hex buffer
IC3—74LS00 quad 2-input NAND gate
IC4—74LS30 8-input NAND gate

Miscellaneous: 34-conductor ribbon cable and card-edge connector, prototype board (or custom PC board for your computer), etc.

Note: IC3 and C4 are not used for Apple interface. IC4 and C5 are used only for IBM PC interface.

The following are available from Micro-Video-Technology, P.O. Box 76, Chattanooga, TN 37343: Custom etched and drilled interface PC board, \$25.00. (Specify your computer when ordering.) Source listing of titler's operating system, V1.0, \$4.00 plus \$2 shipping and handling.

graphics mode I, graphics mode II, multi-color mode, and text mode. Each mode is table-driven and requires the video RAM to be configured differently. In the titler, only graphics mode II is used. That mode gives you the greatest control over pixels and colors.

Table 3 shows the format of data transferred to the VDP registers and video RAM, and the appropriate addresses to use in your BASIC programs. As you can see in the table, two- and three-byte (step) operations are required, as a rule, to transfer data. For example, to write to one of the VDP registers, you must first send the register data, followed by a control byte that tells the VDP that the previous byte was register data. A "1" in the *Most Significant Bit* (MSB) of the second byte transferred establishes that. The three *Least Significant Bits* (LSB's) of the second byte are used to select the register.

Writing to and reading from the video RAM is done in a somewhat similar manner. The eight LSB's of the video RAM address are sent in the first byte. The second byte transferred tells the VDP that a video RAM address is being set up. (A "0" in the MSB does that.) The second MSB of the second byte transferred tells whether a read (0) from video RAM or a write (1) to video RAM will occur. The remaining 6 bits of the second byte provide the 6 MSB's of the video RAM address. Once the 2 byte set-up has occurred, you can write to or read from video RAM.

One convenient feature of the VDP is that you can read from or write to successive locations in video RAM without further set-up. The video RAM address within the VDP is auto-incrementing

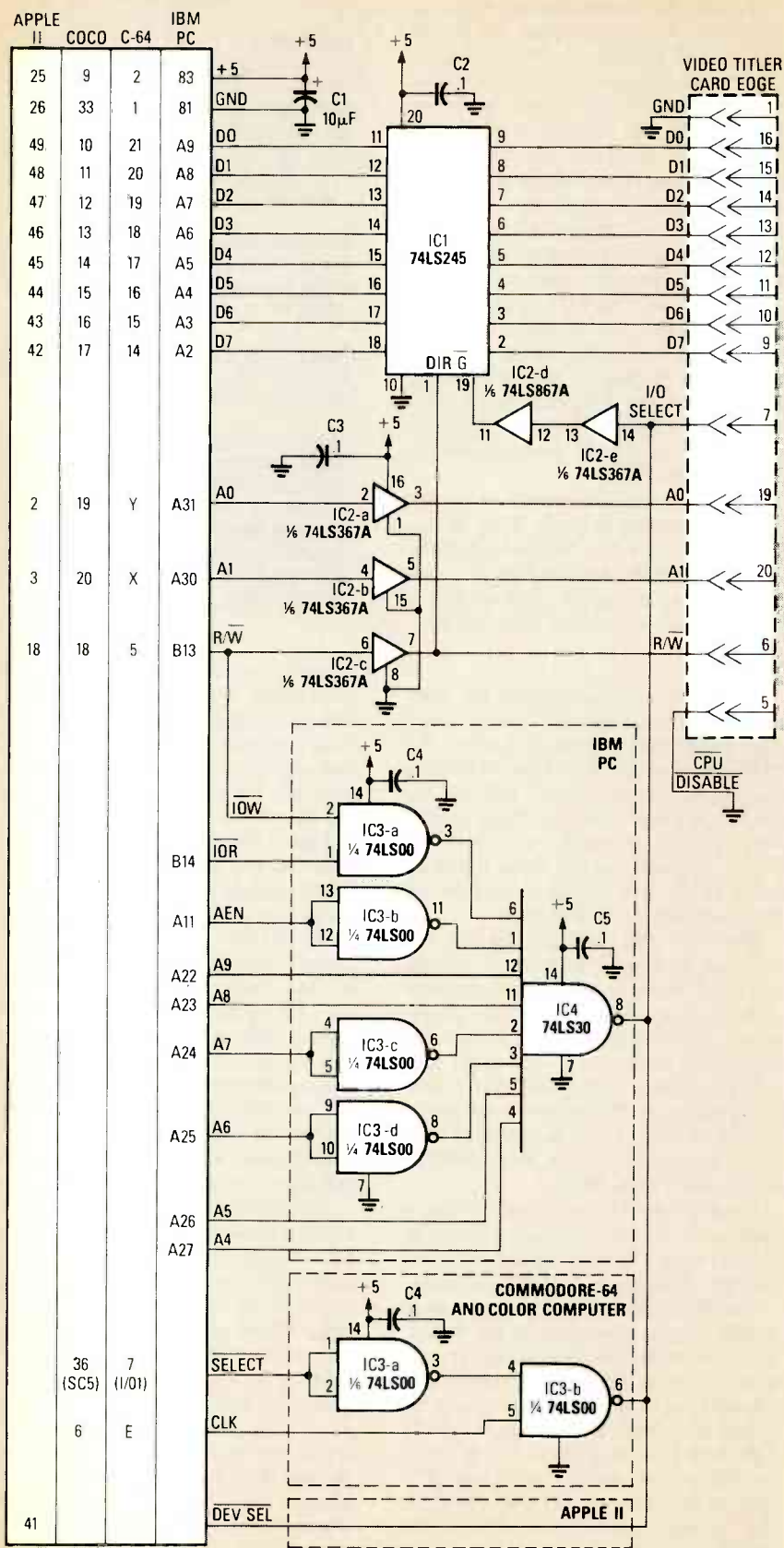

FIG. 20—THE INTERFACE CIRCUIT. The proper bus connections are shown for four popular computers. Note that all the components shown are not needed for all computers. Build the version that's appropriate for your system.

VIDEO TITLER ORDERING INFORMATION

The following are available prepaid from Micro-Video-Technology, P.O. Box 76, Chattanooga, TN 37343: Main PC board, \$40.00. Programmed EPROM (V2.0), \$25.00. Custom keyboard, \$80.00. Custom enclosure, \$40.00. All switches, jacks and connectors, \$30.00 TMS9128 VDP, \$30.00. Partial kit (includes all of the above) \$250. Tennessee residents must add applicable sales tax.

The following are available from JDR Microdevices, 1224 South Bascom Ave., San Jose, CA 95128 (800) 538-5000: All components—except those available from Micro-Video Technology—\$69.95 plus \$2.50 for shipping. California residents must include applicable sales tax.

The following is available from MFJ Enterprises, Inc., 921 Louisville Road, Starkville, MS 39759: Complete titler, assembled and tested with 1 year unconditional guarantee, \$599.95 plus \$6 shipping. (Return if not satisfied within 30 days for refund, less shipping.) (800) 647-1800 (orders only) (601) 323 5869 (information and Mississippi orders). MasterCard and Visa accepted. Mississippi residents must add applicable sales tax.

and—as long as subsequent operations are consistent with the set-up (read or write)—you can zip through memory very quickly. You must, however, recognize certain timing requirements of the asynchronous data transfer. Depending on whether the VDP is actively displaying pixels (as opposed to vertical and horizontal periods), it can take as much as 8 microseconds to transfer data. Therefore, as a precaution, time delays should be included in your software.

VDP registers

The VDP registers are used to select one of the four modes and to configure the video RAM accordingly. Registers contain several other parameters which determine the size of sprites, blank the screen, and invoke the external-video mode. Figure 22 shows a typical way to initialize those registers for graphics mode II.

Generally, only three registers are updated after initialization. The external video flag (EV) in register 0 (bit 0) determines when the VDP is in the external-video mode. (1 = external video on; 0 = external video off). Bit 6 of register 1 blanks and unblanks the screen. (0 = blank; 1 = unblank). The four LSB's of register 7 determine the border color.

You need to remember that the VDP registers are "write-only" so you'll probably want to retain the register data in variables to keep track of them.

TABLE 3—TRANSFERRING DATA TO VRAM AND THE VDP

Operation	TRANSFERRED DATA								ADDRESS FOR STATEMENT						
	MSB	7	6	5	4	3	2	1	LSB	0	"BASIC" statement	Apple II*	C64	COCO	IBM PC
Write to VDP register															
Byte 1 data write	D7	D6	D5	D4	D3	D2	D1	D0			POKE/OUT	49281	56833	65345	817
Byte 2 register select	1	0	0	0	0	RS	RS	RS			POKE/OUT	49281	56833	65345	817
Write to VRAM															
Byte 1 address setup	A7	A6	A5	A4	A3	A2	A1	A0			POKE/OUT	49281	56833	65345	817
Byte 2 address setup	0	1	A13	A12	A11	A10	A9	A8			POKE/OUT	49281	56833	65345	817
Byte 3 data write	D7	D6	D5	D4	D3	D2	D1	D0			POKE/OUT	49280	56832	65344	816
Read from VDP status register															
Byte 1 data read	D7	D6	D5	D4	D3	D2	D1	D0			PEEK/INP	49281	56833	65345	817
Read from VRAM															
Byte 1 address setup	A7	A6	A5	A4	A3	A2	A1	A0			POKE/OUT	49281	56833	65345	817
Byte 2 address setup	0	0	A13	A12	A11	A10	A9	A8			POKE/OUT	49281	56833	65345	817
Byte 3 data read	D7	D6	D5	D4	D3	D2	D1	D0			PEEK/INP	49280	56832	65344	816

*ADD (SLOT# × 16)

TABLE 4—VDP COLOR CODES

Color	Color Codes (Hex)
TRANSPARENT	0
BLACK	1
MEDIUM GREEN	2
LIGHT GREEN	3
DARK BLUE	4
LIGHT BLUE	5
DARK RED	6
CYAN	7
MEDIUM RED	8
LIGHT RED	9
DARK YELLOW	A
LIGHT YELLOW	B
DARK GREEN	C
MAGENTA	D
GRAY	E
WHITE	F

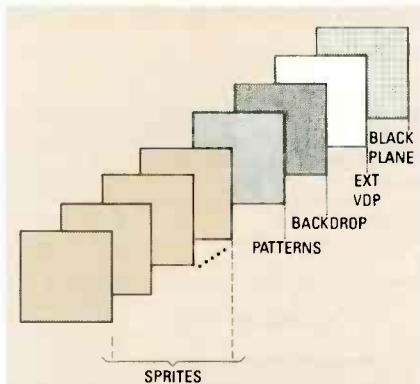

FIG. 21—THE VDP IMAGE PLANES are arranged here in the order of their priority.

Figure 23 shows how the video RAM is mapped under Graphics Mode II. Portions of the addresses of the beginning of each area are loaded (by the system software's initialization routine) into the appropriate VDP register during ini-

REGISTER	7	6	5	4	3	2	1	0	REGISTER DATA	HEX	DECIMAL			
	MSB								LSB					
0	0	0	0	0	0	0	1	0	MODE	EXT VID	02 2			
INTERRUPT ENABLE														
1	1	0	0	0	0	0	1	0	16K	BLANK	MODE	SIZE	MAGNIFY	82 130
PATTERN NAME TABLE														
2	0	0	0	0	1	1	1	0				0E 14		
PATTERN COLOR TABLE														
3	1	1	1	1	1	1	1	1				FF 255		
PATTERN GENERATOR TABLE														
4	0	0	0	0	0	0	1	1				03 3		
SPRITE ATTRIBUTE TABLE														
5	0	1	1	1	1	0	0	0				78 120		
SPRITE PATTERN GENERATOR TABLE														
6	0	0	0	0	0	0	1	1				03 3		
TEXT COLOR 1														
BORDER COLOR														
7	0	0	0	0	0	0	0	0				00 0		

FIG. 22—THE VDP REGISTERS are initialized by the titler's software, and can be updated through the interface, if desired. For the most part, they are not registers in the microprocessor sense, but are used by the VDP to compute addresses for the various name, attribute, color, and pattern tables.

tialization. They coincide with the base address register values in Fig. 22.

In graphics mode II, a 256 × 192-pixel screen is actually made up of 768 8-bit × 8

patterns. Figure 24 shows how those patterns are arranged in 24 rows of 32 patterns per row. Although the pattern definitions could be located almost anywhere in

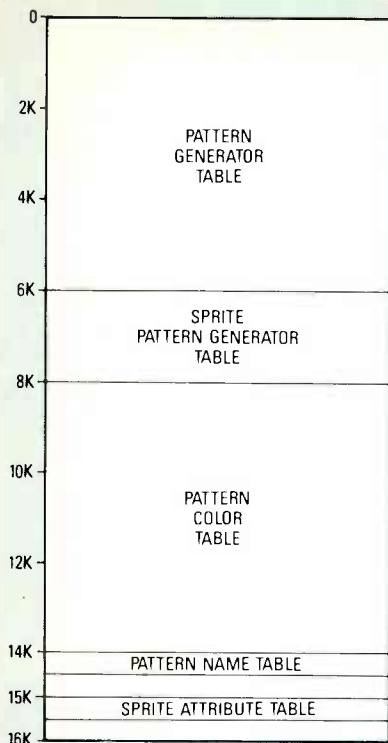

FIG. 23—VIDEO RAM MEMORY MAP. Portions of the base addresses are loaded into the appropriate VDP register upon initialization by the system software.

		COLUMNS		
		0	1	31
0	0	8	248	
	1	9	249	
	2	10	250	
	3	11	251	
	4	12	252	
	5	13	253	
	6	14	254	
1	7	15	255	
	256	264	504	
	257	265	505	
	258	266	506	
	259	267	507	
	260	268	508	
	261	269	509	
23	262	270	510	
	263	271	511	
	5888	5896	6136	
	5889	5897	6137	
	5890	5898	6138	
	5891	5899	6139	
	5892	5900	6140	
5893	5901	6141		
5894	5902	6142		
5895	5903	6143		

FIG. 24—THE SCREEN DISPLAY is made up of 768 8-bit × 8 patterns arranged as 24 rows of 32 patterns.

video RAM, it is easier to arrange them in the order that they appear on the screen. That way, the addresses of the pattern bytes can be computed with a simple algorithm. The equation that can be used to compute the relative address of the first

TABLE 5

```

100 REM THIS SAMPLE PROGRAM PRODUCES SIMPLE
110 REM ANIMATION WITH THE TITLER.
120 REM (SMALL MAN WALKING ACROSS THE SCREEN)
130 REM FOUR FUNCTIONS ARE DEMONSTRATED:
140 REM -VDP INITIALIZATION,
150 REM -TYPE "B" TO INCREMENT BORDER COLOR,
160 REM -TYPE "E" TO ENTER/EXIT EXT. MODE,
170 REM -ANY OTHER KEY RESTARTS THE MAN.
180 REM IT IS DESIGNED TO RUN ON A
190 REM TRS-80 COLOR COMPUTER.
200 REM THE FOLLOWING MINOR CHANGES
210 REM ARE NECESSARY TO RUN
220 REM THIS PROGRAM ON OTHER COMPUTERS:
230 REM C-64: V0=56832,V1=56833
240 REM CHANGE LINE 1100 TO "GET A*".
250 REM IBM PC: V0=816,V1=817, CHANGE ALL
260 REM "POKE" STATEMENTS TO "OUT".
270 REM APPLE II: V0=49290+(SLOT X 16),
280 REM V1=49281+(SLOT X 16).
290 V0=65344;REM VDP PORT,MODE 0
300 V1=65345;REM VDP PORT,MODE 1
310 REM INITIALIZE VDP REGISTERS
320 DATA 2,0,130,1,14,2,255,3,3,4,120,5,3,6,0,7
330 FOR I=1 TO 8
340 READ D:POKE V1,D
350 READ R:POKE V1,R OR 128
360 NEXT I
370 R0=2;R1=130;R7=0
380 PRINT "VDP REGISTERS INITIALIZED"
390 REM CLEAR VRAM
400 PRINT "CLEARING VRAM(1 MINUTE)"
410 A=0:GOSUB 1310
420 FOR I=1 TO 16384
430 POKE V0,0
440 NEXT I
450 PRINT "VRAM CLEARED"
460 REM INITIALIZE SPRITE NAME TABLE
470 REM IN BIT MAP FORMAT
480 A=14336:GOSUB 1310
490 FOR I=1 TO 3
500 FOR J=0 TO 255
510 POKE V0,J
520 NEXT J
530 NEXT I
540 PRINT "NAME TABLE INITIALIZED"
550 REM INITIALIZE SPRITE ATTRIBUTE TABLE
560 A=15360:GOSUB 1310
570 FOR I=1 TO 32
580 POKE V0,208
590 FOR J=1 TO 3
600 POKE V0,0
610 NEXT J
620 NEXT I
630 PRINT "SPRITE ATTRIBUTES INITIALIZED"
640 REM LOAD SPRITE PATTERN TABLE
650 REM WITH 3 WALKING-MAN PATTERNS
660 A=6144:GOSUB 1310
670 REM SPRITE 0,1ST PATTERN
680 DATA 1,3,3,3,1,3,3,5,15,3,3,7,7,14,12,6
690 DATA 192,160,224,192,128,192,240,248
700 DATA 192,192,240,112,96,48,0,0
710 REM SPRITE 4,2ND PATTERN
720 DATA 1,3,3,3,1,3,3,7,3,3,7,14,12,8,0
730 DATA 192,160,224,192,128,192,224,160
740 DATA 192,192,192,192,192,192,192,96
750 REM SPRITE 8,3RD PATTERN
760 DATA 1,3,3,3,1,3,3,5,5,3,7,5,3,3,3
770 DATA 192,160,224,192,128,192,192,160
780 DATA 160,192,224,224,128,128,0,128
790 FOR I=1 TO 96
800 READ D:POKE V0,D
810 NEXT I
820 PRINT "SPRITE PATTERNS LOADED"
830 REM SET UP RED LINE ON SCREEN
840 REM FOR MAN TO WALK ON
850 REM USE 20TH PATTERN ROW,
860 REM ADDRESS=(ROW X 256)+(COLUMN X 8)
870 REM PATTERN 1ST THEN COLOR
880 RW=20;CL=0
890 A=(RW*256)+(CL*8):GOSUB 1310
900 FOR I=1 TO 256
910 POKE V0,255
920 NEXT I
930 REM COLOR IS NEXT COLOR ADDRESS IS 9192
940 REM EITHER 20th PATTERN, COLOR SEND TRANSP.
950 A=(RW*256)+(CL*8)+2192:GOSUB 1310
960 FOR I=1 TO 256
970 POKE V0,96
980 NEXT I
990 REM SETUP SPRITE 0 WITH
1000 REM VERTICAL LOCATION AND BLUE COLOR
1010 A=15360:GOSUB 1310
1020 DATA 142,0,0,4
1030 FOR I=1 TO 4
1040 READ D:POKE V0,D
1050 NEXT I
1060 REM UNBLANK SCREEN
1070 R1=(R1 AND 192)OR((NOT(R1 AND 64))AND 64)
1080 POKE V1,R1:POKE V1,0 OR 128
1090 PRINT "SCREEN UNBLANKED"
1100 A8=INKEY$
1110 IF A8="" THEN 1100
1120 IF A8<"E" THEN 1160
1130 R0=(R0 AND 254)OR((NOT(R0 AND 1))AND 1)
1140 POKE V1,R0:POKE V1,0 OR 128
1150 PRINT "TOGGLE EXT.MODE":GOTO 1100
1160 IF A8<"B" THEN 1210
1170 R7=(R7 + 1)AND 15
1180 PRINT "INCREMENT BORDER COLOR"
1190 POKE V1,R7:POKE V1,7 OR 128:GOTO 1100
1200 REM START OF MAN WALKING
1210 PRINT "ANIMATION INITIATED"
1220 FOR I=0 TO 250 STEP 2
1230 FOR J=0 TO 8 STEP 4
1240 A=15360:GOSUB 1310
1250 POKE V0,I:I=I+2
1260 POKE V0,J
1270 NEXT J
1280 NEXT I
1290 PRINT "ANIMATION COMPLETED"
1300 GOTO 1100
1310 REM SUBROUTINE TO SETUP VDP
1320 REM FOR "WRITE" OPERATION
1330 A2=INT(A/256):A1=A-(A2*256)
1340 POKE V1,A1:POKE V1,A2 OR 64
1350 RETURN

```

		BIT							
		7	6	5	4	3	2	1	0
BYTE	0	VERTICAL POSITION (Y)							
	1	HORIZONTAL POSITION (X)							
	2	NAME							
	3	EARLY CLOCK BIT	0	0	0	COLOR CODE			

FIG. 25—SPRITE GENERATION. One entry of the sprite attribute table is shown here. There are 32 4-byte entries in the attribute table.

byte of each pattern is: ROW × 256 + (COLUMN × 8). To fully define a pixel on the screen, the pattern byte is not enough—a color byte is needed as well. The color information is stored in much the same way as the patterns. The address

of the color byte, however, is exactly 8192 bytes higher than the pattern byte. The most significant nibble of the color byte defines the color of the "1" bits in the pattern byte, and the least significant nybble defines the color of the "0" bits in the

continued on page 78

"Heat-Proofing" your Projects

*Cool down your hot projects
with the devices
discussed here!*

VAUGHN D. MARTIN AND
BILLY W. DAVIS

Part 2 IN JANUARY WE learned about the analogy between heat and electricity; we also learned how to calculate the sizes of heatsinks and forced-air cooling systems. We'll continue this month by discussing some interesting ways of dissipating heat, and several new means of temperature sensing and heat injection. We'll conclude with a discussion of the vortex tube, an old, yet recently revitalized device used for heat dissipation.

Thermoelectric devices

Heatsinks, fans, and blowers are not the only devices that can be used to dissipate heat. Thermoelectric devices may also be used for that purpose, particularly when it is necessary to cool a small area,

or even just one critical component. There are four physical phenomena that give rise to the thermoelectric effect:

- The Seebeck effect is the EMF (electromotive force) that arises when two dissimilar conductors are coupled, and each is maintained at a different temperature. That is the fundamental principle by which thermocouples operate.
- The Thomson effect is the heating or cooling that arises in a homogeneous conductor when an electric current passes in the direction of the temperature gradient.
- The Joule effect occurs when an electric current passes through a conductor that is isothermal (i.e., that maintains the same temperature throughout), and heat, called Joule heat, is generated.
- The Peltier effect describes the effect

an electric current has as it travels through the junction of two dissimilar materials: When current flows in one direction, cooling occurs; when current flows in the opposite direction, heating occurs.

The Peltier Effect is probably the most useful in power-supply design (and in

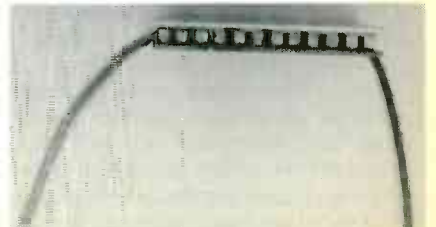

FIG. 8—PELTIER DEVICE dissipates heat in proportion to the amount of current flowing through the device.

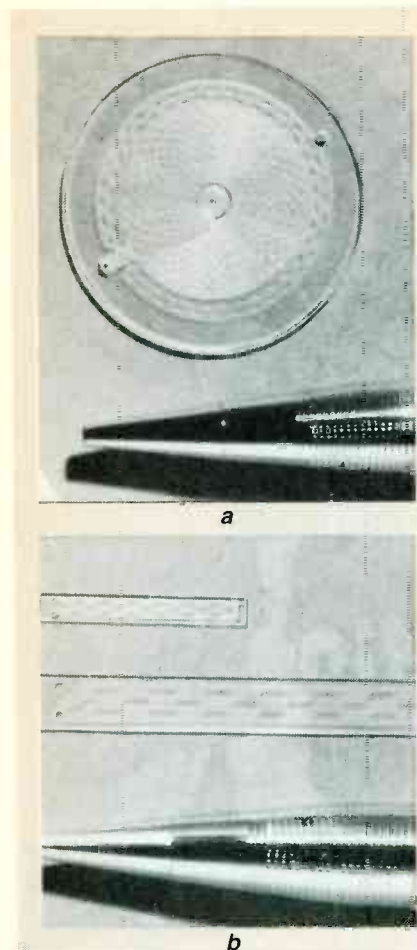

FIG. 9—Joule-Thomson micro-refrigerator can cool a device to the temperature of liquid nitrogen in one second.



FIG. 10—Piezo-electric fan can cool a small area much more efficiently than a regular fan.

electronics generally) because of its ability to literally draw heat away from a semiconductor. Several companies today produce Peltier cooling devices, such as that shown in Fig. 8. A Peltier device may be directly attached to the surface of a heat-producing semiconductor. Heat is drawn away from the semiconductor in proportion to the current passing through the Peltier device. Devices like the one shown cost about \$15 in sizes large enough to cool a TO-3 power transistor.

Another interesting thermoelectric device is the Joule-Thomson cooler; two versions of that device are shown in Figs. 9-a and 9-b. That "micro-miniature re-

frigerator" cools infrared and millimeter-wave detectors down to 77°K, the temperature at which nitrogen becomes liquid, can cool a device to 80°K in just one second.

The piezoelectric fan

Another interesting cooling device is the piezoelectrically-driven fan, like that shown in Fig. 10. That device, manufactured by Piezo Electric Products (212 Durham Ave., CN-15, Metuchen, NJ 08840), is available in both 50- and 60-Hz. and 220- and 117-volt models. The

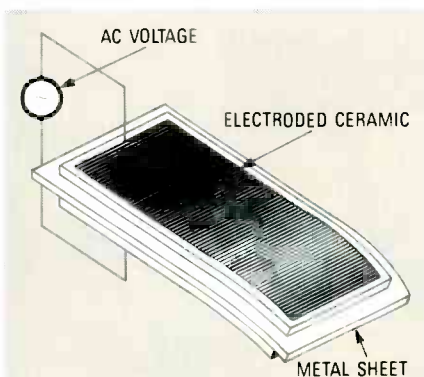

FIG. 11—ALTERNATING CURRENT causes each blade of the piezo fan to distort in turn.

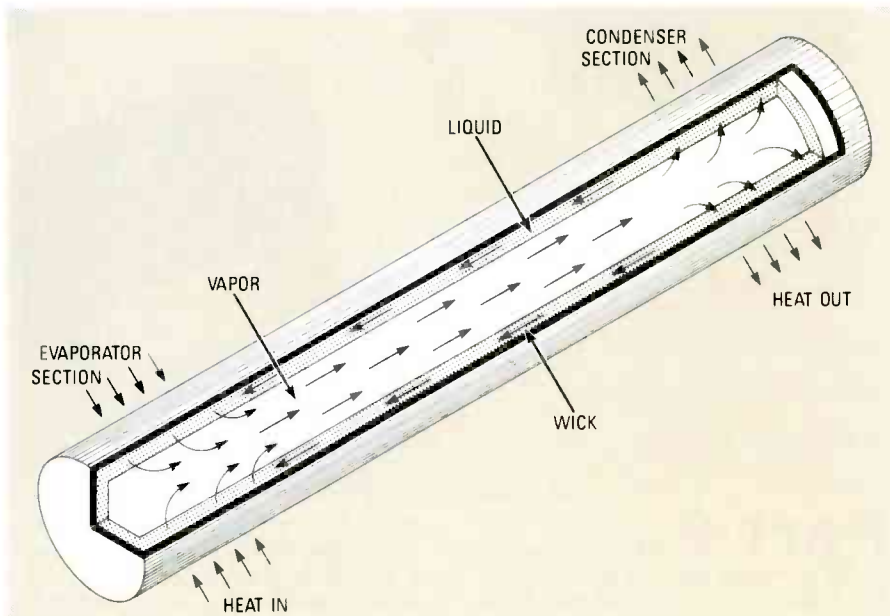

FIG. 12—HEAT PIPE is a sealed tube that is a highly-efficient conductor of heat.

device is used for spot cooling, and it consumes about 1/15 the power of a fan that provides the same cooling effect. The piezo fan has high reliability because of the flexible metal blades laminated to thin-sheet piezo-ceramic elements, as shown in Fig. 11. Mechanical distortion of the piezo elements results when an AC voltage is applied across them; that is what causes the blades to "flap." The highly-focused air streams produced are responsible for the unit's exceptional effi-

ciency: the fan can move 20 CFM, but uses only 0.36 watts of power.

The heat pipe

Heat pipes range in size from furnace liners and smokestacks to pipe-cleaner size objects. As shown in Fig. 12, a heat pipe is a sealed metallic tube that contains highly compressed gas. The highly pressurized and conductive tube can equally and uniformly distribute heat; it operates by principles of both condensation and evaporation. Heat-pipe manufacturers claim that the temperature difference between the object being cooled and its surroundings may be reduced to less than 1°C.

A small heat pipe may fit beneath two adjacent rows of IC pins. If, for example, you had a circuit composed of a row of adjacent LED's, you wouldn't be able to use one of the more common heat ventilating devices, like the slip-on DIP heat-sink shown above, because the heatsink would obscure the front of the display, and therefore render it useless. A heat pipe would be ideal in that situation; as shown in Fig. 13, several heat pipes may be attached to a single PC board. One end would be mounted beneath the LED's, and the other end could be coupled to a

heatsink, to aid in heat dissipation. Another method of increasing heat dissipation is by fusing a "radiator" onto the condenser end, as shown in Fig. 14.

Temperature indicators

A number of companies, including Omega (Box 4047, Stamford, CT 06907) and Telatemp (Box 5160, Fullerton, CA 92635), make paint-on and crayon-like indicators, like that shown in Fig. 15, which may be rubbed onto any surface

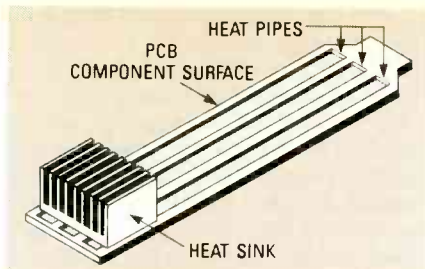

FIG. 13—HEAT PIPES may be coupled to a heat sink for more efficient radiation of heat.

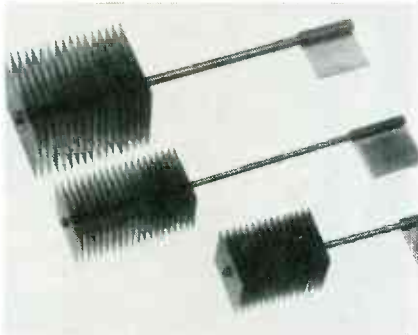

FIG. 14—RADIATING FINNS may also be used for more efficient radiation of heat with heat pipes.



FIG. 15—THIS "TEMPILSTIK"™ changes color at 121°C.

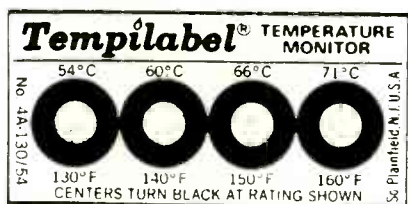

FIG. 16—THIS "TEMPILABEL"™ provides separate indicators that change color at temperatures ranging from 54°C to 71°C.

whose temperature is to be monitored. There are also stick-on temperature indicators, like those shown in Fig. 16, that are specifically designed to be attached to TO-3, TO-66, and DIP devices.

Those indicators function by changing color when the temperature reaches a pre-specified value. They come in two types. The traditional throw-away types change color permanently when the temperature reaches the trip point; they are unable to return to their former color when temperature later drops.

That unfortunate "ratchet" effect has been overcome by an LCD- (Liquid Crystal Display) type temperature indicator. Those indicators do not use nematic crystals; rather, they use cholesteric crystals, which, by the way, come from the cho-

lesterol in lamb's wool and cuttlefish. Those LCD indicators cost about four dollars each, and they may have as many as seven colors, each of which indicates an increment of 5°C. There are larger indicators based on the same principle that can

cover whole power supplies or printed-circuit boards.

Fluoroptic measurement

Liquid-crystal indicators are handy, but sometimes we need a more accurate indication of temperature than they can provide. Infrared sensors, for example, can provide a highly accurate measurement of temperature. Unfortunately, however, they must have an unobstructed line-of-sight to the object whose temperature is being measured. That makes it difficult—or impossible—to measure the temperature of hard-to-access locations.

To overcome that line-of-sight requirement, Luxtron (1060 Terra Bella Ave., Mt. View, CA 94043) has introduced the *Fluoroptic* Thermometer shown in Fig. 17. That device senses temperature by using slender optical fibers, like the one shown in Fig. 18. The *Fluoroptic* probe allows temperature to be determined to an accuracy of 0.1°C over the range of -50°C to +200°C.

The instrument includes a built-in digital LED display, and separate analog and digital outputs for operating strip-chart recorders, CRT displays, digital printers, or control instrumentation. A measurement time of one-fourth second, one second, or four seconds is switch-selectable. The *Fluoroptic* probe has several characteristics that make it especially useful in measuring temperature:

- The probe does not heat up from microwave or RF fields, nor does it distort or perturb the heating field.
- The probe is not conductive electrically or thermally.
- The long, smooth sensor is easily inserted into the body of a research specimen, as shown in Fig. 19.
- The probe is sheathed with a highly inert jacket that ensures chemical neutrality, and that also allows the probe to be gas-sterilized, or to be sterilized in an



FIG. 17—LUXTRON'S FLUOROPTIC THERMOMETER has both analog and digital outputs for peripheral devices.

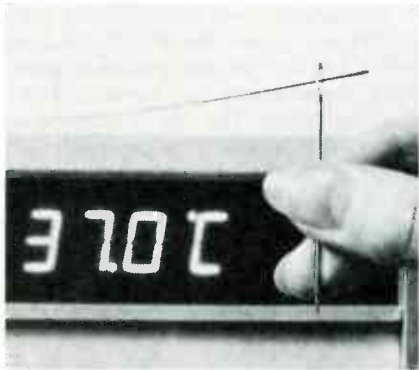

FIG. 18—A RARE-EARTH FLUOROPTIC PROBE can pass through the eye of a needle.



FIG. 19—A FLUOROPTIC PROBE can also pass directly into a biological research specimen.

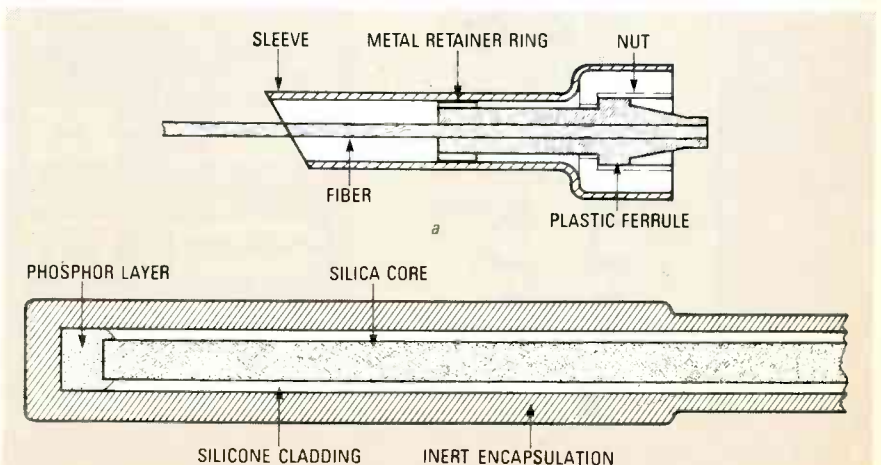

FIG. 20—THE CONNECTOR END OF THE FLUOROPTIC PROBE is shown at a, and the sensing end at b.

autoclave (an instrument that uses high-pressure steam to accomplish sterilization).

- The probe's low thermal inertia allows readings to be obtained in seconds.
- Calibration is intrinsic to the phosphor used. Probes need not be calibrated individually, and, since temperature is determined by comparing the relative intensities of different colors, the system is immune to changes in illumination that might otherwise be interpreted as changes in temperature.

The Fluoroptic probe

The probe shown in Fig. 20 has a diameter of approximately 0.7 mm, and it contains a small amount (10 micrograms) of europium-activated gadolinium oxy-sulfide (a rare-earth phosphor) affixed to its end.

A high-intensity tungsten-halogen lamp sends ultraviolet (UV) light along the fiber to the tip of the sensor, where that light excites the phosphor. That excitation causes visible light to be emitted, and that light returns to the instrument via the same fiber. Then, as shown in Fig. 21, that light is sent by a beam splitter through two separate optical channels where the two wavelengths of interest are isolated by filters and detected by silicon photodiodes. The signals from the photodiodes are amplified, averaged, and converted to digital signals. The averaging time is switch-selectable.

The system microprocessor calculates the ratio of the two averaged signals, and determines the corresponding temperature from a look-up table stored in

read-only memory (ROM). The microprocessor formats the temperature data for the front-panel display, the analog output, and the RS-232C output.

The factor that limits the length of the transmission fiber is the amount of excitation-radiation that is dissipated due to transmission losses in the fiber itself. Existing fibers can extend to 100 meters. Longer fibers—into the kilometer range—could be manufactured if the phosphor were excited by visible (blue) radiation, or by electrons, or by alpha particles from radioactive materials contained within the sensor. Now that we've got some idea of how the *Fluoroptic* system works, let's see what can be done with it.

Applications

To maintain a safe and efficient power-distribution system, the electric-power industry monitors the temperature of generators, transformers, and power-distribution equipment. The use of thermocouples and thermistors is generally not practical, because their outputs may be affected by the high-intensity electrical and magnetic fields that are present. *Fluoroptic* probes are not affected by those fields, and they may provide an easy solution to what has been a tough problem.

Fluoroptic technology can also be used to implement a non-contact sensor. In such a system, a spot of phosphor is affixed to a rotating machine. Then an optical fiber (or a fixed-lens system) senses the temperature of the rotating part from a distance. Corrective measures, if necessary, can then be taken.

Other possible applications include microwave food processing, lamination of wood, forming of plastics, cancer therapy, and anywhere that an accurate, non-contact measurement of temperature must be made. The ultimate development in non-contact sensors might be the throw-away sensor. Possible uses include phosphor sensors painted directly on microwave food pouches, and phosphor beads packaged for use in clinical chemistry.

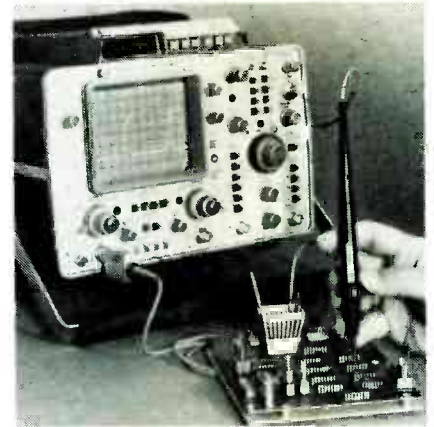

FIG. 22—SEMICONDUCTOR HEAT-SENSOR provides DC-voltage output that is directly proportional to temperature.

Direct-contact probe

Admittedly, *Fluoroptic* temperature measurement is a fairly exotic method of measuring temperature, so probes that rely on direct contact to measure temperature are still useful in many applications. The device shown in Fig. 22, a Hewlett-Packard (3000 Hanover Street, Palo Alto, CA 94304) model 10023A, is a semiconductor device that produces an output voltage that is directly proportional to the temperature it senses. The device is connected to a DVM whose display provides an indication of temperature directly either in degrees Fahrenheit or in degrees Celsius.

Heating probe

You can use a small, hand-held probe not only for measuring temperature, but also for controlling it. For example, MTI (Micro-Technical Industries, 23666 Birtcher Dr. B, Lake Forest CA 92630) markets several "Thermo-probes" for the test-bench and the production-line, as shown in Fig. 23. Those probes allow you to heat—in circuit—specific transistors, IC's, or other electronic components, without using expensive, cumbersome ovens or heat chambers.

The bench model applies heat that is accurate to $\pm 3^\circ\text{C}$ over the range of $+25^\circ\text{C}$ to $+250^\circ\text{C}$, and the production model achieves the same accuracy over the range of $+25^\circ\text{C}$ to $+225^\circ\text{C}$. A reliable, solid-state controller continuously monitors the probe's temperature and regulates that temperature to the value set by the control knob. It takes 35 to 40 sec-

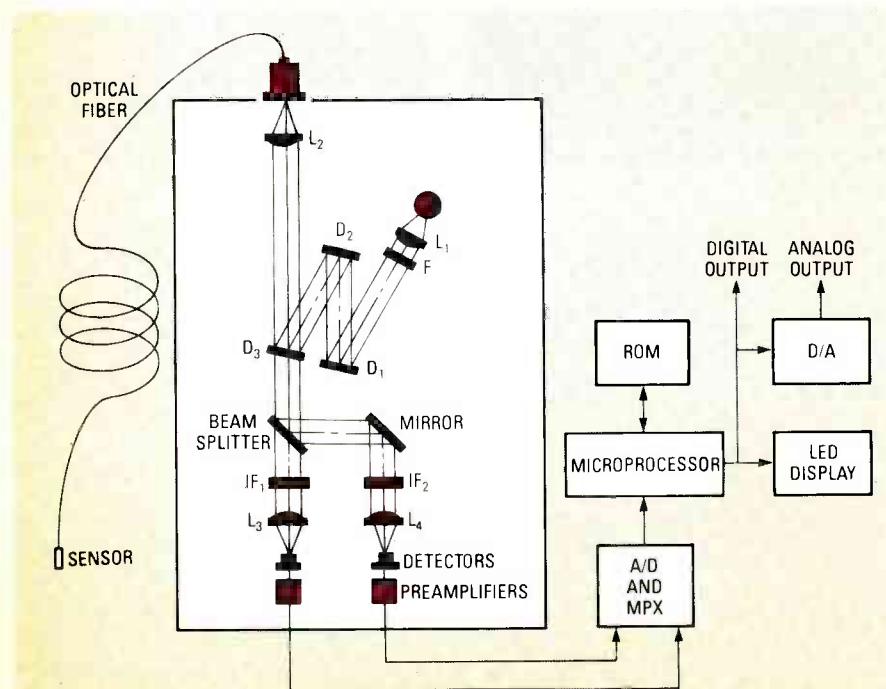

FIG. 21—BLOCK DIAGRAM OF THE FLUOROPTIC THERMOMETER is shown here. Note that a single optical fiber transmits excitation energy to the probe as well as the resultant signal from it.



FIG. 23—THERMO-PROBE CAN SUPPLY PRECISELY-CONTROLLED TEMPERATURE. The production-line model is shown here; a test-bench model is also available.



FIG. 24—VORTEX TUBE has no moving parts, yet it is a very efficient cooling device.

onds, depending on the model, to bring the probe to the specified setting from ambient temperature. Tips are available that fit most common electronic components; custom tips are also available.

The vortex tube

Now let's turn gears and return to talking about heat dissipation, and, in particular, the mostly unknown vortex tube, an example of which is shown in Fig. 24. Unlike traditional cooling devices, the vortex tube uses no electricity or water, and it creates no vibration or EMI (*ElectroMagnetic Interference*). The vortex tube has no moving parts, and it requires only a source of clean, compressed air to produce powerful cooling effects. The vortex tube operates on the principle that, when a compressed gas expands through an orifice, the gas cools.

The vortex tube was discovered by French physicist Georges Ranque. However, upon describing his discovery to a French scientific society, he was met with disbelief. Several years later, Rudolph Hilsch, a German scientist, discovered Ranque's work: Hilsch subsequently revived interest in the device. It is interesting to note that vortex tubes made of pure silver were found in German laboratories by the Allies at the end of World War II. Their intended use was never discovered!

The basic operating principle of the vortex tube is illustrated in Fig. 25-a, and an exploded view of an actual vortex tube is shown in Fig. 25-b. High-pressure air is forced through the inlet to the generator. That air then enters the body assembly, where it loses pressure as it expands and attains a velocity near the speed of sound.

That low-pressure, high-velocity air then enters the hot tube. The air does not enter the cold tube because the opening to the hot tube is larger than the opening to the cold tube (the diaphragm). Centrifugal force then keeps the air near the inside surface of the hot tube as it moves toward the control valve at the end.

By the time that hot air reaches the valve, it has a pressure that is less than the exit pressure at the nozzles, but that is greater than atmospheric pressure (assuming that the cold outlet at the opposite

end of the tube is at atmospheric pressure). The pressure just inside the control valve is always greater than the cold outlet pressure.

The position of the control valve determines how much air leaves at the hot end. For proper hot-cold separation, the valve must allow only part of the air to escape. The remaining air is then forced through the center of the hot tube, the generation chamber, and finally the diaphragm, after which it exits at the cold outlet.

The original stream of air in the hot tube did not travel through the center of the tube because of the centrifugal force of the pressurized inlet air. That is how the path for the inner stream is created. And that, in conjunction with the pressure difference between the control valve outlet and the cold outlet, is the reason that there are two distinct spinning streams, one inside the other, that move in opposite directions through the hot tube.

Now that we understand how air flows through the vortex tube, let's examine the reason why the hot air becomes hot and the cold air becomes cold. As we said, the outer ring of air moves through the vortex tube toward the hot end, and the inner core of air moves toward the cold end. Both streams of air are rotating in the same direction. More important, both streams of air are rotating at the same angular velocity. That is because intense turbulence at the boundary between the two streams locks them into a single mass, so far as rotational movement is concerned.

The proper term for the inner stream

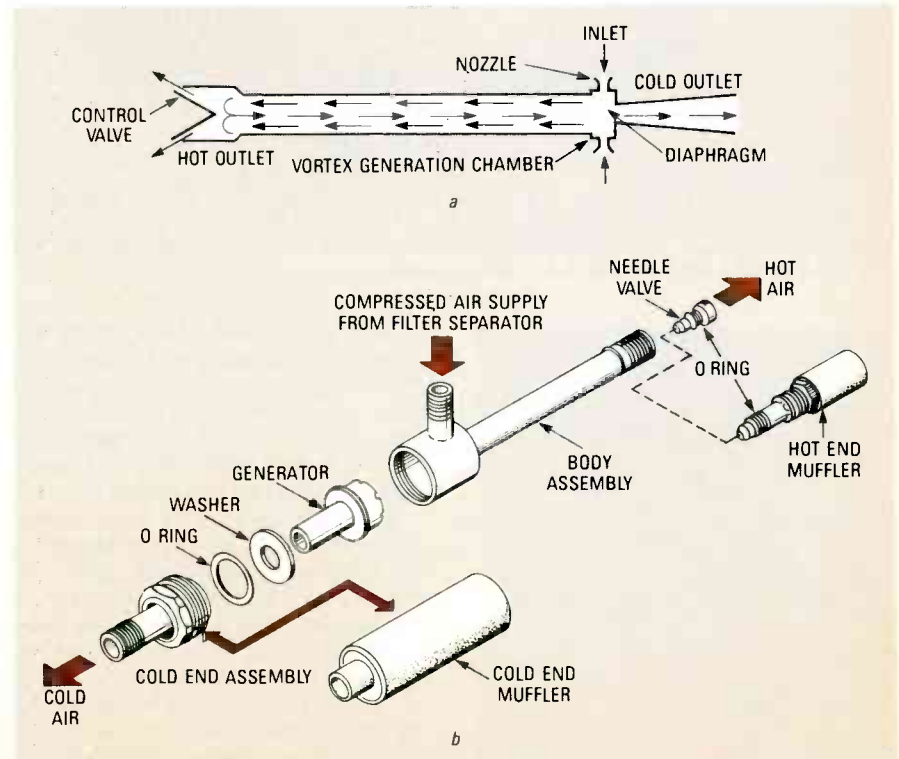

FIG. 25—VORTEX TUBE'S PRINCIPLE OF OPERATION is shown at a, and an exploded view of an actual vortex tube is shown at b.

would be a *forced vortex*, which is distinguished from a *free vortex*, in that the rotational movement of a forced vortex is controlled by an outside influence rather than by the principle of the conservation of angular momentum. In the case of the vortex tube, the outer (hot) stream forces the inner (cold) stream to rotate at a constant angular velocity.

By contrast, angular momentum is conserved in, for example, a bathtub whirlpool, which is a free vortex. The linear velocity of any particle in a free vortex is inversely proportional to its radius. So, in moving from a radius of one unit to a drain at a radius of 1/2 unit, a particle *increases* its linear (tangential) velocity by a factor of *two*. In a forced vortex with constant angular velocity, linear velocity *decreases* by *half* as a particle moves from a radius of 1 unit to a drain at a radius of 1/2 unit.

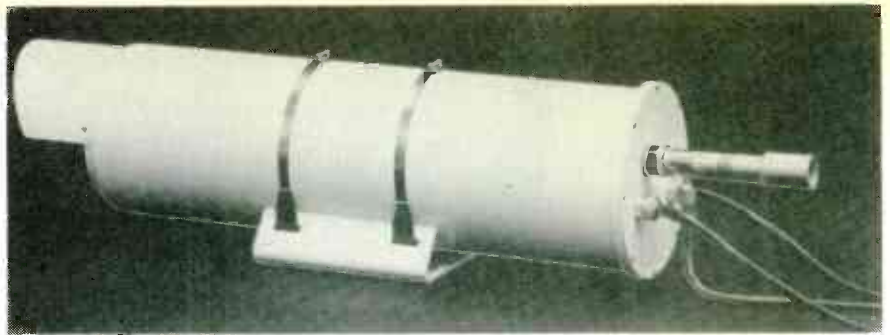

FIG. 28—INDUSTRIAL TV CAMERA is cooled by a vortex tube. This camera can operate in environments with temperatures as high as 200°F.

Therefore particles enter the drain of a free vortex with four times the linear velocity of a forced vortex. Kinetic energy is proportional to the square of linear velocity, so particles entering the drain of a forced vortex have 1/16th the kinetic energy of a free vortex.

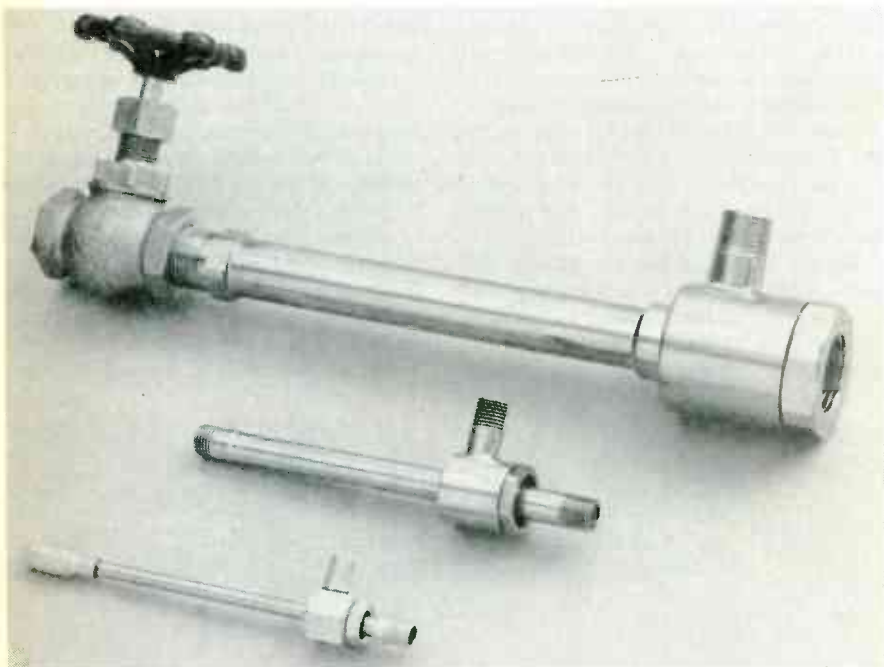

FIG. 26—VORTEX TUBES come in several different sizes.



FIG. 27—A THERMOSTAT may be an integral part of a vortex tube.

Where does that excess energy go? Therein lies the secret of the vortex tube. That energy leaves the inner core as heat! And that heat is transmitted to the outer air stream. So why isn't the outer layer heated by the same amount that the inner layer is cooled, leaving no net cooling effect?

Keep in mind that the outer stream's rate of flow is always greater than that of the inner stream, since part of the outer stream is discharged at the hot valve. If the amount of heat leaving the inner stream equals the amount of heat gained by the outer stream, the temperature drop of the inner stream must be greater than the temperature gain of the outer stream because its mass rate of flow is smaller. And that is the origin of the vortex tube's surprising cooling ability.

Real-world vortex tubes

Several examples of actual vortex tubes are shown in Fig. 26. Tubes of various sizes can be useful in providing different amounts of cooling. Some vortex tubes have built-in mechanical thermostats, as shown in Fig. 27. Vortec Corporation (10125 Carver Road, Cincinnati, OH 45242) manufactures a number of different vortex tubes, and that company sells several kits for experimenting with them.

A commercial application of a vortex tube is shown in Fig. 28. The device shown is an industrial television camera that can be used without damage in environments with temperatures as high as 200°F. The air coupled through the hose connected to the front of the housing provides the vortex cooling effect.

Conclusions

We have covered a lot of ground in this two-part article on heat and electronics. Last month we examined ways of controlling heat in electronics devices, particularly semiconductors. As we learned, heat flows by means of conduction, radiation and convection: all three must be taken into account when designing heat-ventilating systems. The analogy between the flow of heat and the flow of electricity allows heatsink area and air-flow requirements to be calculated easily.

This month we have examined several new devices that provide creative solutions to difficult heat-flow problems, and we mentioned several modern methods of temperature indication. We then discussed Luxtron's *Fluoroptic* thermometer and several probes used for both sensing heat and controlling it. To bring things to a close we then discussed vortex tubes in depth.

We hope that, by applying what you have learned here, your next design—whether it be a 7805 regulator circuit or a high-current power supply—should function much better.

We would like to thank TAB Books for granting permission to quote portions of TAB book number 1557; thanks also goes to National Semiconductor and Fairchild Semiconductor for permission to reproduce copyrighted material.

R-E



Repairing Compact Disc Players

Compact disc players are the most exciting development in audio in years. In this article we'll show you how those devices work, and how you can repair them when something goes wrong.

JOHN LENK

Part 5 PREVIOUSLY, WE'VE covered many different types of CD-player failures, and their likely causes. But there are still a few that we haven't looked at. Let's pick up where we left off.

4. Pickup does not focus properly. Figure 29 is the troubleshooting diagram. When play first begins, the focus actuator coil receives a focus up-down (FUD) signal from IC301 through IC101 and IC102. Those FUD pulses move the focus actuator up and down two or three times as necessary to focus the beam on the disc. Once focus is obtained, a focus-ok (FOK) signal

is generated by IC601 and applied to both IC301 and IC301. If IC301 does not receive an FOK signal after two or three tries, it shuts the system down and play stops (turnable off, pickup moves to inner-limit). On most players, that also occurs if there is no disc in place.

If focus is obtained, the focus error (FER) signal from IC601 is applied to the focus actuator through IC101 and IC102. The FER signal keeps the pickup focused on the disc. On most players, when the pickup reaches the outer limit, focus is lost, the FOK signal is removed, and IC301 shuts down the system.

If you suspect problems in the automatic focus (AF), install a disc, select play, and check that the pickup moves up and down two or three times, and then settles down. If not, check the laser (and adjust the laser if necessary). Then make a quick check of the lens actuator coils. Here's how:

Measure the resistance of focus and tracking coils with an ohmmeter. Typically, the resistance of the focus coil is about 20 ohms, while the resistance of the tracking coil is 4 ohms. Actual resistance depends on the pickup. However, if you get an open, a short, or a resistance that is

way off, the actuator is suspect. On some players, you can see a slight movement of the actuator when the ohmmeter is connected to the coils.

If the coil appears good, and the problem can not be corrected by adjustment, check the focus servo as follows.

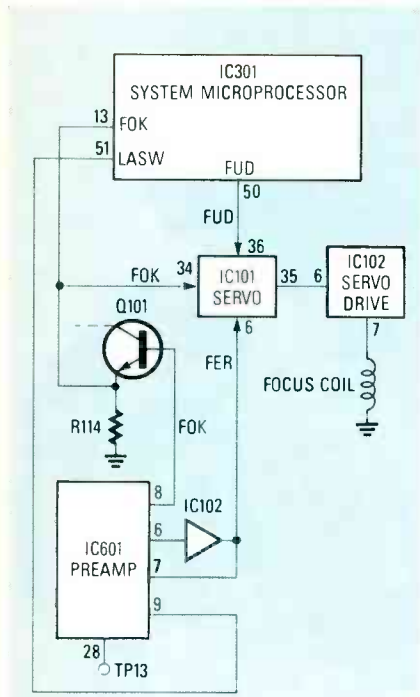

FIG. 29—THIS DIAGRAM should be used to help track down the cause of focusing problems.

If the FUD pulses are not present just after PLAY is selected, suspect IC301. Check for pulses at pin 50 of IC301, pins 35 and 36 of IC101, pins 6 and 7 of IC102, and at the coil.

Next, check for FOK signals at pin 34 of IC101, pin 13 of IC301, and pin 8 of 601. (If the FOK signals are not present, IC301 should shut the system down.) If the FOK signals are absent at pin 8 of IC601, suspect IC601, or possibly the four pickup photodiodes. Also, the FOK signal is not generated unless the LASW signal is applied to pin 9 of IC601.

Next check for FER signals at pins 6 and 7 of IC601. If FER signals are present at pin 6, but not at pin 7, suspect IC102. If FER signals are absent at pin 6, suspect IC601, or possibly the photodiodes.

If you suspect the signal/focus photodiodes, monitor the EFM signal at TP13 (TDET). If EFM is good, it is reasonable to assume that all four photodiodes are good.

5. Pickup does not track properly. Figure 30 is the troubleshooting diagram. In most players, it is very difficult to separate tracking and focus servo problems. For example, unless there is an FOK signal applied to IC101, the tracking error (TER) signal does not pass to the tracking actuator. Both the focus and tracking servos

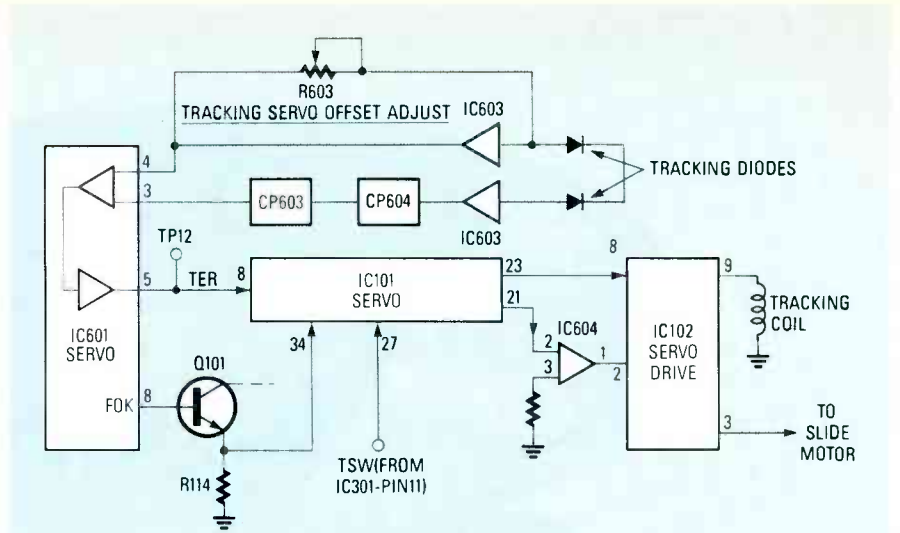

FIG. 30—BEFORE DECIDING that the servo IC (IC101) is bad, be sure that that all of the inputs to that device are okay (consult the service manual for the player for more details).

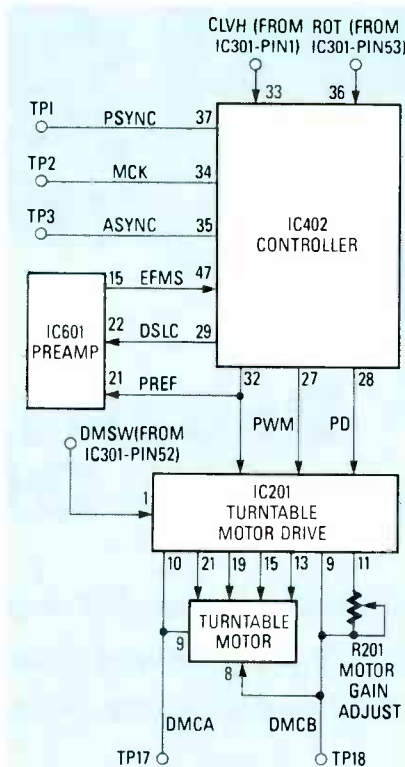

FIG. 31—WHILE IT'S EASY to tell whether or not a turntable motor is working at all, it is more difficult to determine whether or not it is working correctly. If not, use this diagram to find the cause.

use the laser beam as a source of error signal (although different photodiodes are used). To make it worse, TER is also used by the pickup motor as a fine speed control (that takes place in IC101). If TER is lost, both the radial tracking coil and the pickup motor have no control signals. Either condition can produce symptoms of improper tracking.

First try to correct any tracking prob-

lems with adjustment. Next, make a quick check of the tracking actuator coil. Then see if the pickup moves to the inner limit when power is first applied. (That confirms that the pickup motor, reset circuit, and the basic servo is good.) If the motor and coil are good, and adjustments do not correct the problem, check the following:

Trace the TER signal from its source to the tracking actuator coil and pickup motor. (Note that TER is not applied to the pickup motor in all players.) If the TER signal does not reach IC102, IC101 is usually at fault. However, before you pull IC101, remember that IC101 must receive a number of signals before TER can pass. Two such signals are FOK and TSW. (In some players, the TER signals are also analyzed for errors in IC101.) If FOK or TSW are absent or abnormal, or if there are excessive errors in the TER signals, IC101 is cut off and FER signals do not pass. So always check the signals and voltages at the pins of IC101 (using the service manual values) before you decide IC101 is bad.

6. Disc motor (turntable) does not rotate properly. Figure 31 is the troubleshooting diagram. It is easy to tell if the turntable is not spinning, and you can usually pin down the cause of such total failure. For example, you can easily check for DMCA and DMCB drive signals to the motor windings. The problem is not quite that simple if the motor rotates, but you are not sure of the correct speed (especially since the motor speed is constantly changing). You must rely on waveform measurements and adjustments. So the first step in disc motor circuit troubleshooting is to perform the adjustments. However, before you decide there is a problem in the disc motor control circuits, consider the following.

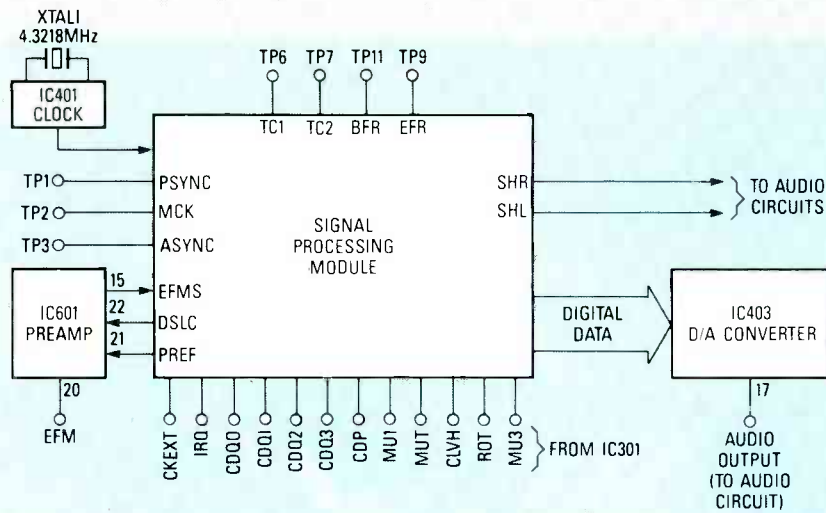

FIG. 32—A FAULTY signal-processing module can cause a variety of audio and motor-control problems.

Check PWM, PEF, and PD from IC402. If any are absent or abnormal, suspect IC402. Next, trace the signals between IC201 and the motor. Suspect IC201 if any or all signals appear to be normal (check the service manual for waveforms and amplitude), suspect the disc motor (probably the Hall elements, but possibly the windings).

Also note that PEF is applied to IC601, along with the DSLC signal from IC402, to form the EFMS signal, which is returned to IC402. If EFMS is absent, IC402 does not produce PEF, PWM, and PD signals. If EFMS is absent, you will also have several other problems. You can make a quick check of EFMS by comparing the signals at TP1 (PSYNC) and TP3 (ASYNC) using a dual-trace scope; both signals should be synchronized. If not, or if either signal is missing, suspect IC402.

In any player, the disc-motor control circuits are closely related to the signal processing circuits. A failure in signal processing can appear as a failure in disc motor control. So if you are unable to locate a problem in the disc motor, check the signal processing circuits.

7. Signal processing circuit problems. Figure 32 is the troubleshooting diagram. A failure in signal processing can cause a variety of failure symptoms in both audio and disc-motor control circuits. Likewise, a failure in system control can appear as a failure in signal processing. From a practical standpoint, there is no sure-fire way to tell if the problem is in signal-processing, system-control, disc-motor, or audio signals. However, there are checks that will help pin down the problem.

First off, check for audio at the D/A converter output (pin 17 of IC403). You should get both left and right-channel low-level audio. If you get no audio at that point, suspect signal processing. If there is measurable audio at that pin, the problem is likely in the audio circuits.

Next, if there are excessive audio dropouts, and the front-panel indications are not normal, the problem is likely in signal processing. Check all of the waveforms to and from the signal processing circuits shown in the service literature. Pay particular attention to the following (using Fig. 32 as a guide).

Check for a 4.3218-MHz signal at TP2 (MCK) of the signal-processing module. If that signal is missing, suspect the clock, IC401, as well as the signal-processing module itself. Check TP1 (PSYNC) and TP2 (ASYNC) for 7.35-kHz signals. The ASYNC should be present only during PLAY, but PSYNC should be available in both STOP and PLAY.

Make certain that PEF and DSLC are supplied to IC601, and returned to the signal-processing module as squarewave EFMS signals. If EFMS is missing, check

continued on page 78

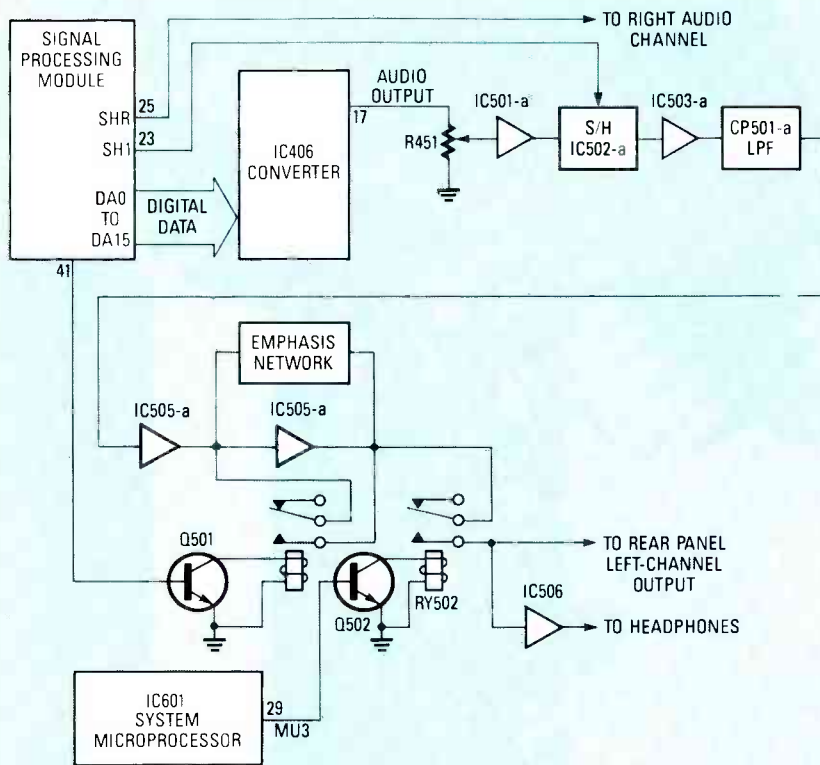

FIG. 33—WHEN TROUBLESHOOTING the audio circuits, be sure to check for an erroneous muting signal from the microprocessor. Such a signal can prevent the audio signal from reaching the unit's outputs.

The DMSW, CLVH, and ROT signals must come from the system microprocessor. IC301, before IC402 will apply disc motor signals to IC201. In most players, if IC301 does not get an FOK (and possibly a TOK signal) from the focus and tracking circuits, the DMSW, CLVH, and ROT signals are set to prevent IC402 and IC201 from passing the PEF, PWM, and PD signals to the motor. Typically, both DMSW and CLVH are made low to turn on the disc motor when PLAY is selected; and ROT

goes low about one second later. If all three signals remain high after PLAY is selected, check for FOK and TOK to IC301. If only one of the three signals is abnormal, IC301 is most likely at fault.

If you get the DMCA and DMCB drive signals, and the motor is turning (indicating that DMSW, ROT, and CLVH signals are good), but you are unable to set the output levels as described, check all of the waveforms associated with disc motor control as follows:

ONE OF THE MOST ATTRACTIVE FEATURES of TV servicing is its similarity to detective work. One picks up a clue, and then forms a theory. He then follows that theory to its ultimate conclusion. If, along the way, he finds that the direction he's going in is not bringing him closer to a solution, he studies the case again, picking up another clue that may take him in a different direction. Like a good detective, if the technician stays with the "case" long enough, he will eventually "catch the culprit." Some may feel that the preceding metaphor stretches the point a bit, but anyone who's been faced with a particularly difficult troubleshooting problem will tell you that it is appropriate. Let's look at a few examples.

Some TV troubleshooting problems can drive even an experienced technician crazy.

FRANK A. SALERNO

A change in direction

Our first example deals with a Zenith 19CC19Z chassis with an open 2.7-amp fuse. When a new fuse was installed, and the set turned on, the 19CG3 damper-tube plates began to glow red. That, of course, meant that the tube was drawing heavy current. The plug was quickly pulled, but not before the fuse had blown again.

Some preliminary checks revealed that the 24-volt Zener diode, CR212 (see Fig. 1), was shorted. That diode is supposed to keep the 24-volt supply at a constant level. That finding led to the theory that, since there was no 24 volts, the horizontal oscillator became disabled, causing excessive current flow through the output tube, resulting in an overheating damper tube.

Confidently, the Zener diode was changed and the set turned on. Naturally, the 19CG3 began to glow red again, and in short order, the fuse blew. Oh, yes, the new Zener was also gone. With that, the set was taken to the shop.

Once there, the first step was to see what was going on in the 24-volt supply. After removing the Zener, a voltmeter was clipped to the 24-volt line. At turn-on, the meter read 24 volts and continued to do so until the tubes warmed up and began to conduct. As the damper developed its first blush, the meter moved up to 26 volts. As the glow deepened, the meter moved higher and higher. At 32-volts, the plug

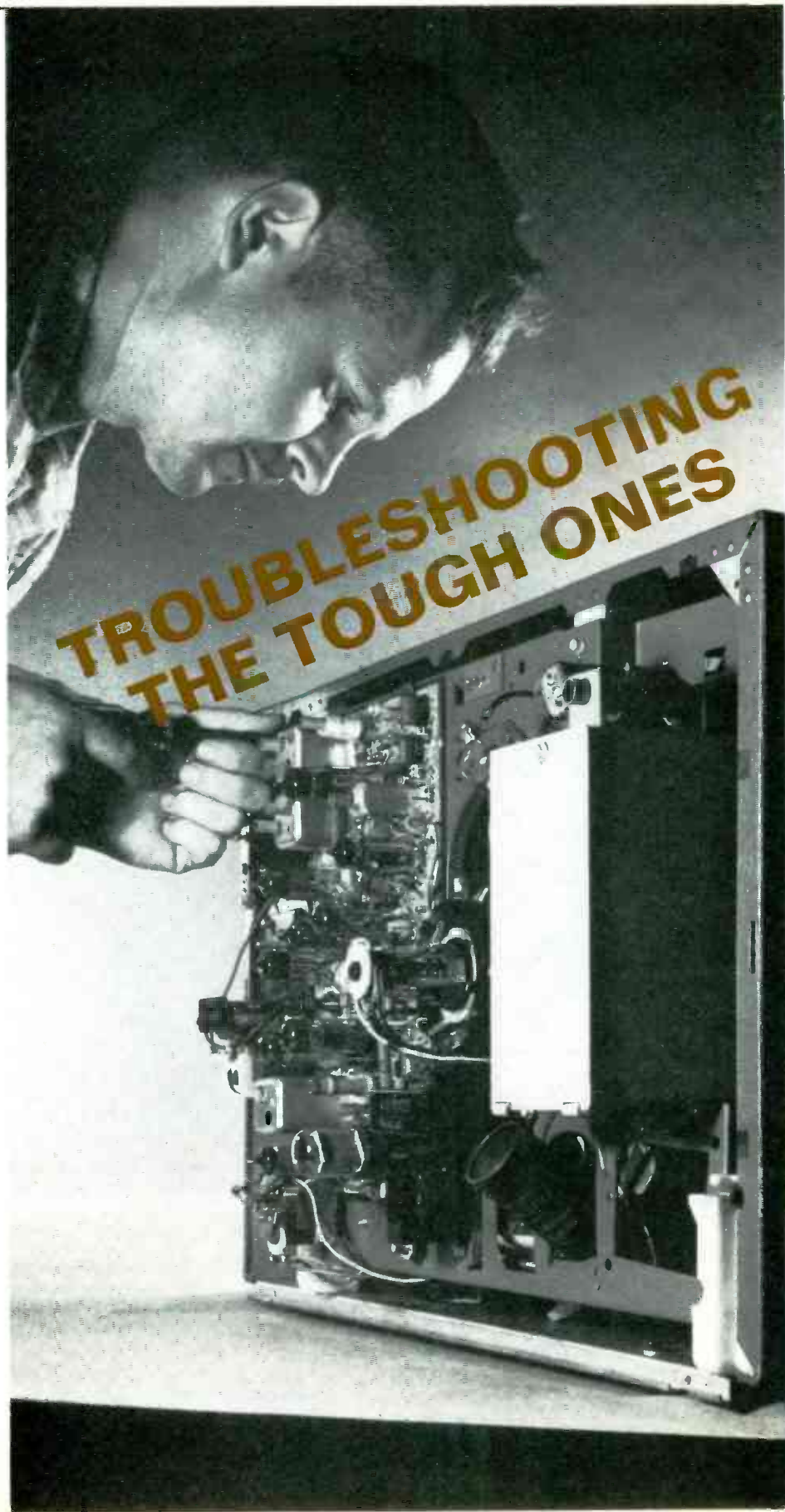

was yanked to prevent any further damage.

It was obvious that we would need to follow a different path to track down the cause of the failure. Our tests revealed that it was not the 24-volt supply that was draining the output circuit. Instead, something in the damper circuit was driving up the 24-volt line. Investigating further, a low resistance reading from the 19CG3 cathode to ground turned up a shorted pincushion transformer. What was apparently happening here was that the saturated current in the main B+ supply created a higher AC input to the 24-volt supply. A new transformer corrected the problem.

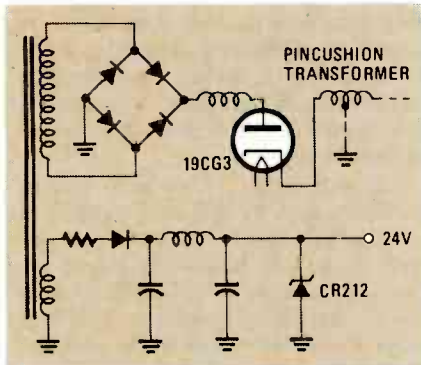

FIG. 1—THE 24-VOLT ZENER, CR212, in this set was repeatedly blowing. The cause turned out to be a shorted pincushion transformer.

Short picture

A Sony KV1201 demonstrated that the smoke and the fire can sometimes be in two different places. The set lacked vertical size, showing just a third of the picture across the screen; no foldover, no distortion—just a short picture. The first step, of course, was to take voltage measurements. Those measurements showed just the opposite of what was expected. The voltages on the collectors of both the driver and the bottom output transistors were almost twice what they should have been. That seemed odd since in a case of insufficient sweep you would expect lower than normal voltages, not higher than normal ones. Nevertheless, tracing back to the source of those two voltages led to the regulated 130-volt supply, which was also reading high. The cause was a shorted regulator transistor.

Putting in a new regulator brought these questionable readings back to normal, but it had no effect on the picture size. Considering what we've just said, that was not too surprising a result.

Next, an oscilloscope was used to take measurements around the driver and output transistors. The measurements matched those called for on the schematic: 115-volts p-p at the driver collector and 125-volts p-p at the input to the deflection yoke. Yet, though those two readings were fine, the picture was far from it.

Suddenly, a thought occurred. It was

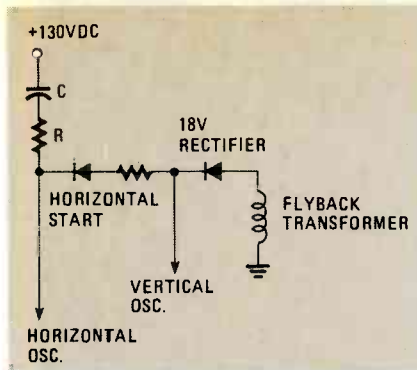

FIG. 2—THE OUTPUT OF THE 18-volt rectifier is used to keep the horizontal oscillator running after turn on.

true that the two key waveforms viewed before were right on the button, but those tests were performed with both the height and linearity controls cranked up to their maximum. Where was the reserve power? It was time to take a closer look at the oscillator. That stage is independent of the two controls. Sure enough, though the schematic called for 4.5-volts p-p at the collector, the reading there was only 2.5-volts p-p. DC voltage at the collector should have been 13; the reading was 7. Tracing those voltages back led this time to the 18-volt scan-derived supply. It was low, and for good reason—the 18-volt rectifier was open (see Fig. 2).

Briefly, the scan-derived supply works like this: At the moment that the on-off switch is turned on, a voltage pulse that is sufficient to get the horizontal oscillator going is generated. The output transistor then amplifies the oscillator signal, causing the flyback transformer to generate high voltage pulses. Several of those pulses are tapped off the flyback and rectified. Those rectified voltages are then used to supply power to different sections of the receiver.

The 18-volt rectifier is a critical component in this case because its output is fed back to the oscillator to sustain operation. Without that 18 volts, the oscillator will not operate because the pulse that gets it going in the first place is there only at turn on.

The wayward capacitor

Our next case deals with an RCA CTC97 whose horizontal frequency was way off, causing a loss of sync. While that could be caused by an oscillator problem, there is another possibility. In many RCA models, when there is an excessive high voltage condition, an overvoltage protection circuit goes into conduction and throws the oscillator off. The circuit is put there to satisfy HEW regulations limiting X-ray exposure. Should the high-voltage (nominally about 26 kilovolts) go too high, causing excessive radiation, the circuit renders the TV inoperable.

To isolate the cause of the problem, the protection circuit needs to be disabled.

That is done by shorting point A (see Fig. 3) to ground. If doing so restores the horizontal sync, it is safe to assume that the set is in overvoltage shutdown. In the case under discussion, sync was not restored, so the oscillator circuit itself was suspect.

Using that magnificent piece of test equipment in a can, circuit cooler, the AFC transistor was sprayed. Instantly, the picture slid into place. A replacement transistor was installed, the set was tested for a day, and then delivered.

As you might guess, two days later the set was back. In the shop, the same routine was followed. After first clearing the protection circuit, the AFC transistor was sprayed with circuit cooler and again, without a moment's hesitation, the picture locked right in. This time, a direct RCA replacement was used.

After two days of testing and two more

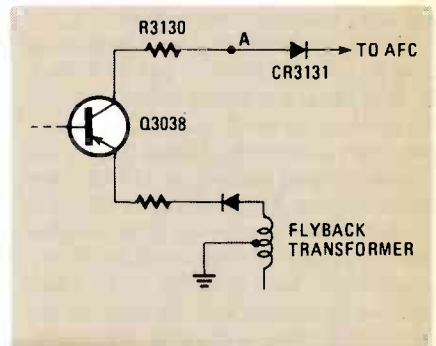

FIG. 3—THIS SHUT-DOWN CIRCUIT cuts off operation in the event of an excessive high-voltage condition.

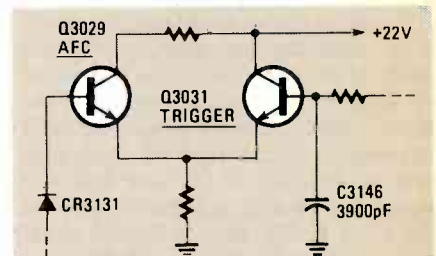

FIG. 4—THROUGH TRIAL AND ERROR, capacitor C3146 was found to be the one that most affected frequency. Replacing it cured the problem.

days in the customer's home, the set was back a third time. Now, though, the AFC transistor was not so compliant. Instead, it seemed that everything had become temperature sensitive. This was one of those times that circuit cooler would not do the trick.

Instead, it was time to resort to the process of elimination. Studying the schematic, those capacitors that would most affect frequency were singled out. By bridging each one in turn with a separate low-valued unit, the most critical one was found to be C3146 (see Fig. 4). As that was as good a place to start as any, that capacitor was replaced. The set has worked fine ever since.

CD SERVICE

continued from page 75

for high-frequency EFM signals at pin 20 of IC601.

Check all signals (ROT, CLVH, etc.) between IC301 and the signal-processing module as shown in Fig. 32. It is not practical to analyze the waveforms of those signals. However, if you can view a data stream on each line with a scope, it is reasonable to assume that the signal is correct. If one or more of those signals is missing, suspect IC301, the signal-processing module, or both. Remember that a signal from IC301 can depend on a signal from the signal-processing module, and vice versa. So you may have to replace both the IC and the module to find the problem. Also remember that IC301 may not produce the required signals unless FOK, TOK, etc., are applied to it.

Before you pull the signal-processing module, check TP6 (TC1) and TP7 (TC2). Both of those test points (which indicate the accuracy of the C1- and C2-decoding processes within the signal-processing module) should produce a 7.35-kHz signal during stop, but then drop to 200 Hz or less when PLAY is selected. If not, suspect the signal-processing module. Next, check TP11 (BFR) and TP9 (EFR) which indicate the accuracy of the sync and detection functions within the signal-processing module. During PLAY, BFR should always be zero, except during groove skipping. During PLAY, EFR may produce a signal, but at a frequency below 50 Hz.

8. Audio circuit problems. Figure 33 is the troubleshooting diagram. The first check of the audio circuits is to monitor the output of the D/A converter (pin 17 of IC406). Next, check the sample-and-hold SHR and SHL signals from the signal-processing module. If the SHR and SHL signals are present, and there is audio at pin 17 of IC406, trace the audio signal from IC406 to the rear-panel jacks.

Also look for any muting or emphasis signals from the system microprocessor, IC601, and/or the signal-processing module. For example, if MU3 from IC601 is low, Q502 does not conduct, and RY502 remains open. That prevents audio from passing to the output.

Operating problems

We will not go into programming and operating problems in this article. Such problems usually start with the system microprocessor, or possibly the front-panel wiring. For example, if you press PROGRAM, REPEAT, etc., and the player does not respond properly, check that the system microprocessor is receiving the command from the front-panel switch or button. If not, check the switch and wiring. If the command is received, suspect the system microprocessor. R-E



SAVE THE STARS.

■ When you lose your vision, you lose the stars. ■ You lose the sunsets. The rainbows. The snowflakes and moonlight. ■ This year, 50,000 Americans will lose all that and more. Forever. ■ Yet in many cases, blindness can be prevented. ■ We're the National Society to Prevent Blindness. ■ We sponsor medical research to conquer eye diseases. We sponsor safety programs to eliminate eye injuries. ■ We fight to save all the things people lose when they lose their eyesight. ■ Help us save the stars. ■ Give to Prevent Blindness.



**National Society
to Prevent Blindness**

Box 2020, Madison Sq. Station, NY, NY 10159

VIDEO TITLER

continued from page 66

pattern byte. Table 4 lists the color codes.

Sprites

Sprites are generated using two tables: the *sprite attribute table* and the *sprite pattern generator table*. The sprite attribute table can contain 32 entries; each entry requires 4 bytes of information. Those 4 bytes are shown in Fig. 25.

The vertical position (Y) of the sprite, which has a value from 0 to 191, is referenced to the upper left pixel. If a value from -31 to -1 is placed in the vertical-position byte, the sprite will appear to bleed down from the edge of the border. A value of 201 (D0H) in the vertical position will blank out the sprite. The horizontal position (X) of the sprite, which has a value from 0 to 255, is also referenced to the upper left pixel.

The color of the "1" bits in the pattern are determined by the least significant nybble of byte No. 3 of the *sprite attribute table*. The "0" bits in the pattern are always transparent. If the MSB of byte No. 3 is set, the entire sprite will shift 32 pixels to the left to allow the sprite to bleed in from the left border.

Byte No. 2 of the sprite attribute table contains the name (relative address) of the sprite pattern map (which is stored in the sprite pattern table). The sprite pattern map requires 32 bytes to define each sprite.

Sample BASIC program

Now that you know the basics of the VDP and sprites, you can write a BASIC program to manipulate a VDP image. The listing in Table 5 is a sample BASIC program that will help you understand how to do it. The program initializes the VDP in Graphics mode II with the register data in Fig. 22. Video RAM mapping is shown in Fig. 23.

The program loads sprite data for three 16 x 16-pixel sprites into the sprite pattern table. And three sprites are manipulated in such a way that a man appears to run across the screen.

As you may have already realized, there are a variety of things to do once the VET and home computer are connected. Your imagination is the only limit. The best approach is to experiment with PEEKs and POKEs to create images. Use the program we presented as a base and expand it as you learn more about how the VDP works.

The titler can really dress up your home videos and be a tremendous outlet for creativity. With the help of the Texas Instruments *VDP Programmers guide* that we mentioned earlier, and a little experience, you can superimpose images that you never thought possible. R-E

PC SERVICE

One of the most difficult tasks in building any construction project featured in **Radio-Electronics** is making the PC board using just the foil pattern provided with the article. Well, we're doing something about it.

We've moved all the foil patterns to this new section where they're printed by themselves, full sized, with nothing on the back side of the page. What that means

for you is that the printed page can be used directly to produce PC boards!

Note: The patterns provided can be used directly only for *direct positive photoresist methods*.

In order to produce a board directly from the magazine page, remove the page and carefully inspect it under a strong light and/or on a light table. Look for breaks in the traces, bridges between traces, and in

general, all the kinds of things you look for in the final etched board. You can clean up the published artwork the same way you clean up your own artwork. Drafting tape and graphic aids can fix incomplete traces and doughnuts, and you can use a hobby knife to get rid of bridges and dirt.

An optional step, once you're satisfied that the artwork is clean, is to take a little bit of mineral oil and carefully wipe it

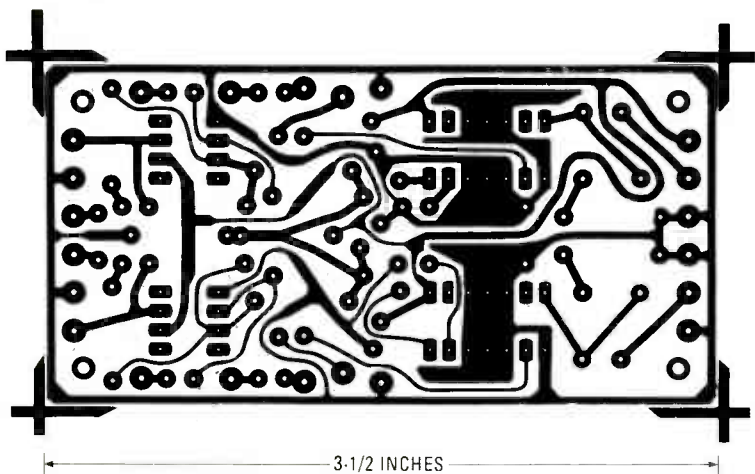

GET ROOM-FILLING SOUND from your walkman-type player with our easy-to-build amplifier. The board for the project, which begins on page 59, is shown here.

PC SERVICE

across the back of the artwork. That helps make the paper translucent. Don't get any on the front side of the paper (the side with the pattern) because you'll contaminate the sensitized surface of the copper blank. After the oil has "dried" a bit—patting with a paper towel will help speed up the process—place the pattern front side down on the sensitized copper blank, and make the exposure. You'll

probably have to use a longer exposure time than you are probably used to.

We can't tell you exactly how long an exposure time you will need but, as a starting point, figure that there's a 50 percent increase in exposure time over lithographic film. But you'll have to experiment to find the best method for you. And once you find it, stick with it. Don't forget the "three C's" of making PC boards—care,

cleanliness, and consistency.

Finally, we would like to hear how you make out using our method. Write and tell us of your successes, and failures, and what techniques work best for you. Address your letters to:

Radio-Electronics
Department PCB
500-B Bi-County Blvd.
Farmingdale, NY 11735

USE THIS BOARD for the power supply required by our stereo-TV decoder.

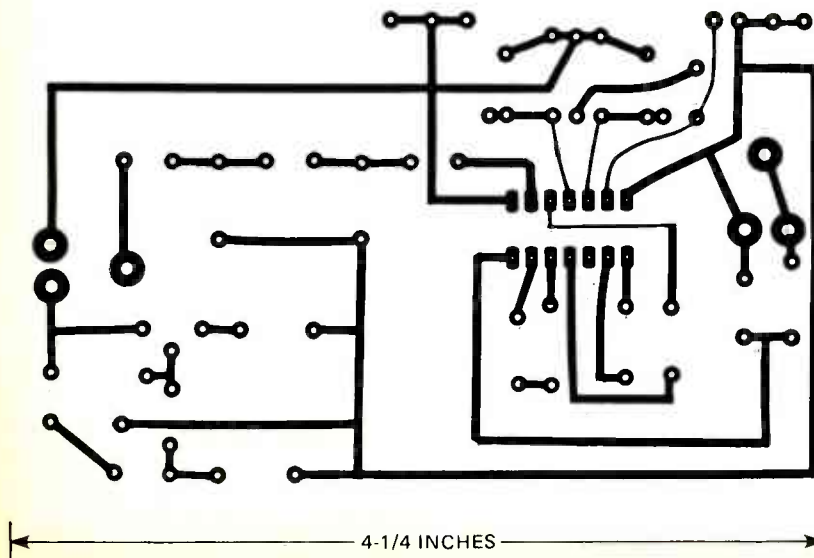
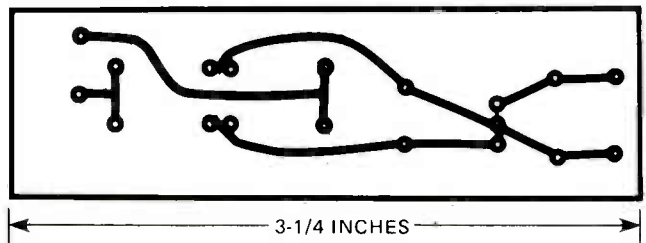

HEAR YOUR FAVORITE TV SHOWS in stereo with our stereo-TV decoder. The main board is shown here; the story begins on page 51.

SATELLITE TV



BOB COOPER, JR.
SATELLITE TV EDITOR

It's Kate—bar the door!

EVER SINCE THE BIRTH OF HOME SATELLITE TV in 1979, there has been a persistent problem with the quality of TVRO products. The victim has usually been the consumer, but dealers have certainly suffered, too. And the reason is simply that equipment often fails to work as it should.

That problem has been getting worse, recently, since a number of semi-important equipment suppliers have collapsed. Collapses like that leave consumers with no factory-supported warranty service. So, to protect themselves, TVRO dealers have been requesting that receiver and actuator suppliers provide at least a schematic diagram for every unit they sell.

But many manufacturers have resisted honoring those requests; apparently, they fear that valuable trade secrets might leak out if schematics were distributed on a widespread basis. But withholding schematic diagrams offers no real protection. Any marginally-talented circuit copier would need no schematic, and the amateurs who do require schematics pose no real market-share threat.

Now dealers have reached the point where they are demanding schematics from OEM's if the dealers are going to handle that OEM's products. Some dealers have been burned so many times by collapsing OEM's that they simply won't handle a new product unless they're provided with a schematic and some basic service information. And that is understandable.

Problem components

Antenna actuators have been the source of most product



FIG. 1

failures through the years. By the actuator, I'm referring to both the motor drives that mount at the antenna to "jackscrew" the dish through the satellite orbit belt, and the indoor controller that

TVRO dealer "Starter Kit" available

Bob Cooper's *CSD Magazine* has arranged with a number of TVRO equipment suppliers to provide a single-package of material that will help introduce you to the world of TVRO dealership. A short booklet written by Bob Cooper describes the start-up pitfalls to be avoided by any would-be TVRO dealer, in addition, product data and pricing sheets from prominent suppliers in the field are included. That package of material is free of charge and is supplied to firms or individuals in the electronics service business as an introduction to the 1984/85 world of selling TVRO systems retail.

You may obtain your *TVRO Dealer Starter Kit* free of charge by writing on company letterhead, or by enclosing a business card with your request. Address your inquiries to: *TVRO STARTER KIT*, P.O. Box 100858, Fort Lauderdale, FL 33310. That kit *not* available to individuals not involved in some form of electronics sales and service.

gives the actuator directions about when and where to move.

Typically, those two parts are sold together, but they are seldom built by the same manufacturer. Most actuator builders concentrate their talents on the controller and go to outside sources (like Saginaw) to acquire the linear-actuator portion. The controller and the actuator are then integrated in the field by the installing dealer, who connects the motorized jackscrew between the fixed and the moving portions of the dish—the post mount and the reflector surface, respectively.

There has never been an attempt to standardize that connection, so every designer creates his own installation scheme. And the problem is compounded for the dealer by the wide variety of antennas, no two of which has the same mounting scheme.

We see the importance of the actuator-dish interconnection scheme when an antenna system is subjected to severe pressure from wind, rain, and ice. There are about 50 manufacturers of home-style TVRO antennas, but only a handful of those manufacturers publish wind-tunnel test data for their antennas, and those tests are often conducted using non-comparable techniques. The bottom line is that the antenna is a major portion of a TVRO system's cost, but the structural strength of most commercially-sold devices is unproven.

The big blow

A late-season storm, Hurricane Kate, originated north of Puerto Rico in mid-November, 1985; Kate

provided us with some interesting data on the strength of several antenna-mount systems.

For more than six years, this writer has been conducting extensive TVRO-systems research in a little-known former British colony, the Turks and Caicos Island. Hurricane Kate cut directly across that isolated island with winds between 105 and 110 miles per hour for more than 4½ hours. Our antenna test range had 25 operating antennas before the storm hit.

Most antennas suffered extensive damage; only 2 of those 25 antennas, shown in Fig. 1, functioned normally after Kate had gone. We learned several things from that storm, including:

- Antenna mounts are the weak link in present antenna designs. Dealers who have been pushing antenna manufacturers to produce light-weight mounts out of thin material have been asking for the wrong thing.
- A well-designed, properly-in-

stalled mesh antenna takes a beating better than a solid antenna. However, a poorly-designed, improperly-installed mesh antenna will suffer damage just as extensive as will a solid type.

- Motor drives—neither the older linear-actuator style nor the newer horizon-to-horizon direct drives—cannot provide the required “braking power” to keep an antenna from moving in hurricane-force winds.
- Metal fatigue (caused by antenna parts being “beaten to death” when supports break and allow the antenna to free-wheel in the storm) may be the least-understood element in antenna failure. One-inch steel bolts and ¼-inch-thick steel washers are simply sheared off after being beaten repeatedly against other antenna parts.

Several years ago, one supplier of mesh-style antennas—Paracclipse—conducted wind-tunnel tests with their twelve-foot antennas. The wind turbines produced winds greater than hurricane force (over 75 miles per hour), and then, to properly simulate actual conditions, thousands of gallons of water were poured into the wind turbines. A handful of antenna suppliers copied those tests, and all reported that their antennas had passed those tests. Paracclipse created an advertising campaign that highlighted the rigors of their testing, but that campaign graciously neglected to pan some of the solid metal and fiberglass antennas that failed those tests. I won't be so generous.

Two that passed

As we said above, when Kate headed away from the Turks and Caicos, we found that only two antennas (out of 25) still worked properly. More than half of those that were totally destroyed; most of the others were eventually put back into service after replacement parts arrived.

The two fully-operational antennas after the storm were both Paracclipse models: a 16-footer and a 9-footer. Both antennas have substantial mounts—not simple pipe mounts—and both have horizon-to-horizon drives. And that drive mechanism is significant.

SATELLITE TV/

The First Five Years!



THE MOST COMPLETE report on the mushrooming home TVRO industry ever compiled, written as only the 'father of TVRO' could have prepared. More than **1000 pages** (!) tracing the complete story of home TVRO, lavishly illustrated with equipment photos, schematic diagrams, equipment analysis reports. **Bob Cooper**, the first private individual to own and operate a TVRO (1976) has collected and polished hundreds of individual reports into a unique 'collector's edition' which clearly explains the TVRO phenomenon in North America. From Coop's first 20 foot 'monster' dish to the present day 5 foot 'C-band' TVROs, the fascinating growth of TVRO equipment and its legal status unfolds for you.

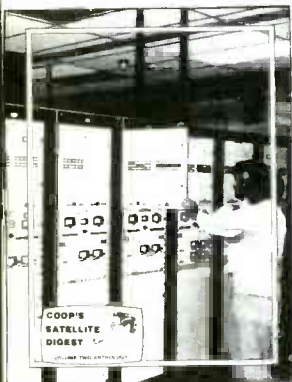

THIS TWO VOLUME SET totaling more than 1,000 pages is available for the first time to readers of **Radio-Electronics** at special discount pricing. **Originally sold** at \$100 per two-volume set, a limited supply is now available **ONLY** through this advertisement. **PLUS**, you will also receive a special extraordinary bonus; the 200 page (+) **October 1984** edition of **CSD/Coop's Satellite Digest**. This very special edition of CSD is a best-seller in the TVRO industry, with the most comprehensive collection of TVRO facts and figures ever compiled. Combined with the 1,000 page 'CSD ANTHOLOGY' report, you have instant reference to **everything** you will ever need to know about the state of the home TVRO industry. It is **MUST** reading for every person in, or thinking about 'getting into,' any segment of the home TVRO world.

___ **SEND CSD ANTHOLOGY/2 Vols. + CSD Bonus.**
 ___ **SEND CSD October '84 Special Issue ONLY.**

NAME _____ COMPANY _____

ADDRESS _____

CITY _____ STATE _____ ZIP _____

Payment: \$60 US funds (Anthology + Bonus), \$15 US funds CSD Oct. **ONLY**; payable "CSD ANTHOLOGY."
 Shipping charges prepaid. Enter order to: **CSD Anthology**, Radio-Electronics Magazine, 200 Park Av. S., New York, NY 10003; or call 305-771-0505 for credit card orders **ONLY**.

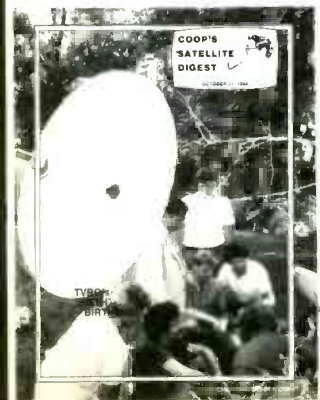

The idea behind the horizon-to-horizon drive is that, rather than pushing or pulling on the dish with an in-line jackscrew, the dish is driven from one horizon (east) to the opposite horizon (west) with a chain, belt, or hydraulic gear system.

The linear actuator allows the dish to cover only about 50% of the Clarke Orbit Belt. The linear actuator, then, has finite limits: typically, when the dish is nearly straight up (due south) at one end of the range of travel, and close to the western horizon when the dish is at the opposite end of travel.

Linear actuators typically have a continuous-gear threaded rod that is driven by a small, often plastic, gear wheel. Under the extreme pressure of a hurricane, the dish can actually force the threaded rod to turn, even though no electricity is applied to the motor. When the linear actuator is pushed to one end or the other, wind pressure continues and all its force is absorbed by the gear-wheel teeth.

The gear teeth then break off, so the antenna is free to flap in the wind. It flaps back and forth, eventually breaks off, and then slams into the ground, the post mount, or the concrete pad, where it is usually destroyed. When the storm ends, the antenna has been beaten to a pulp; and the motor system, the mount, and everything else associated with the antenna are all unreparable.

We had four horizon-to-horizon antennas operating before the storm. Two of those not only survived, but were still accurately aimed when the storm moved on. Of the other two, one (a 20-foot ADM) survived with only minor damage to the hydraulic drive system. As best we can reconstruct, the hydraulic system acted as a high-tension safety brake on the motor drive. Even under 100-mile/hour winds, it only allowed the 20-foot solid antenna to slip gradually across the belt.

Our fourth horizon-to-horizon antenna was totally destroyed because a part of the concrete-pad anchoring system failed. That allowed the antenna to break loose and flip backward in the winds. Once it had been ripped from the

concrete pad, the antenna beat itself to death on that pad.

Other antennas also failed through no fault of their own. A sixteen-foot heavy-duty (USS) fiberglass antenna, for example, failed because we apparently selected an anchoring system that was weaker than the antenna's mount. The winds simply got behind and under the antenna and literally pried it out of the concrete pad by yanking the lag bolts out of the concrete.

Looking back, those 3-inch long \times $\frac{3}{4}$ -inch-diameter "lags" should have been $\frac{3}{4}$ -inch bolts imbedded into the concrete pad at least 12 inches with rebar (steel) supports attached to the heads of the bolts.

Next month we'll share some conclusions on antenna integrity with you; we'll also make some recommendations on how you can protect yourself from antenna failure when your antenna is subject to severe winds and other heavy loading conditions. **R-E**

Radio-Electronics REPRINT BOOKSTORE

- | | | | |
|---|---------|--|--------|
| <input type="checkbox"/> Build Your Own Robot | \$12.00 | <input type="checkbox"/> Special Projects #4 (Summer 1982) | \$4.50 |
| <input type="checkbox"/> 8-Ball Satellite TV Antenna | \$5.00 | <input type="checkbox"/> Special Projects #5 (Winter 1983) | \$4.50 |
| <input type="checkbox"/> Radio-Electronics back issues (1985) | \$3.00 | <input type="checkbox"/> Special Projects #6 (Spring 1983) | \$4.50 |
| Write in issues desired | | | |
| <input type="checkbox"/> Radio-Electronics back issues (1984) | \$3.50 | <input type="checkbox"/> Special Projects #7 #8 #9 NOT AVAILABLE | |
| (January 1984 not available) | | | |
| Write in issues desired | | | |
| <input type="checkbox"/> Radio-Electronics back issues (1983) | \$3.50 | <input type="checkbox"/> Special Projects #10 (Spring 84) | \$4.50 |
| (January, February 1983, May 1983 not available) | | | |
| Write in issues desired | | | |
| <input type="checkbox"/> Radio-Electronics back issues (1982) | \$4.00 | <input type="checkbox"/> Radio-Electronics Annual 1983 | \$3.50 |
| Write in issues desired | | | |
| <input type="checkbox"/> Radio-Electronics back issues (1981) | \$4.00 | <input type="checkbox"/> Radio-Electronics Annual 1984 | \$3.50 |
| (Jan., Feb., March, Dec. 1981 not available) | | | |
| Write in issues desired | | | |
| <input type="checkbox"/> Etch your own PC boards | \$3.00 | <input type="checkbox"/> Radio-Electronics Annual 1985 | \$3.50 |
| <input type="checkbox"/> Hands On Electronics #1 | \$4.00 | <input type="checkbox"/> Radio-Electronics Annual 1986 | \$2.50 |
| <input type="checkbox"/> Hands On Electronics #2 | \$4.00 | <input type="checkbox"/> How to Make PC Boards | \$2.00 |
| <input type="checkbox"/> Hands On Electronics #3 | \$4.00 | <input type="checkbox"/> All About Kits | \$2.00 |
| <input type="checkbox"/> Hands On Electronics #4 | \$4.00 | <input type="checkbox"/> Modern Electrics (Vol. 1 #1 | \$2.25 |
| <input type="checkbox"/> Hands On Electronics #5 | \$3.50 | April 1908) | |
| <input type="checkbox"/> Hands On Electronics #6 | \$2.50 | <input type="checkbox"/> Electro Importing Co. Catalog | \$4.95 |
| <input type="checkbox"/> VCR Repairs | \$3.00 | (1918) (176 pp) | |
| <input type="checkbox"/> IBM Typewriter to | | <input type="checkbox"/> Low Frequency Receiving Techniques | \$6.00 |
| <input type="checkbox"/> Computer Interface | \$3.00 | Building and using VLF Antennas | |
| | | <input type="checkbox"/> New ideas - 42 circuits for experimenters | \$3.50 |
| | | <input type="checkbox"/> Descrambler (Jan., Feb., 1981) | \$3.00 |
| | | <input type="checkbox"/> Descrambling (Feb., 1984) | \$2.00 |
| | | <input type="checkbox"/> Build Your Own Satellite TV Receiver | \$7.00 |
| | | <input type="checkbox"/> Receiving Satellite TV | \$7.00 |

To order any of the items indicated above, check off the ones you want. Complete the order form below. **include your payment**, check or money order (DO NOT SEND CASH), and mail to Radio-Electronics, Reprint Department, 500-B Bi-County Boulevard, Farmingdale, NY 11735. Please allow 4-6 weeks for delivery.

If you need a copy of an article that is in an issue we indicate is unavailable you can order it directly from us. We charge 50¢ per page. Indicate the issue (month & year), pages and article desired. Include payment in full, plus shipping and handling charge. Make checks payable to Gernsback Publications, Inc.

ARTICLE _____

PAGES _____

MONTH _____

YEAR _____

TOTAL PAGES _____

(@ 50¢ each)

TOTAL PRICE _____

MAIL TO: **Radio-Electronics** Reprint Department,
500-B Bi-County Boulevard, Farmingdale, NY 11735

All payments must be in U.S. funds

Total price of order

Sales Tax (New York State Residents only)

Shipping & Handling (U.S. & Canada only) (Includes FIRST CLASS POSTAGE) \$1.00 per item

All other countries (\$2.00 per item, sea mail)

(\$4.00 per item, air mail)

Total Enclosed

Name

Address

City

State

Zip

SERVICE CLINIC

Voltage regulators

BY MURPHY'S LAW, "ANYTHING THAT can go wrong will go wrong," and voltage regulators are no exception. Most solid-state sets have voltage regulators, so we've got to be able to troubleshoot them. Fortunately, voltage regulators aren't really complicated, so they're easy to fix by following standard troubleshooting procedures and the hints I'll give below.

A regulator can be a single IC, or it can be built from discrete components. Either way, it's easy to check if it's working properly. Assuming that the input voltage is correct, all you have to do is measure the regulator's output voltage. If it isn't exactly what the schematic calls for, you've got trouble. If you measure no output voltage, another component may have shorted the output line, so don't automatically assume that the regulator is bad.

If the output appears to be shorted, disconnect the regulator's output from the rest of the circuit and then measure the regulator's output voltage. If it's not what it should be, the regulator is almost certainly bad. But if that voltage is what it's supposed to be, connect a low-value power resistor across the output, and then measure the voltage. If it's still within specifications, the regulator's OK, and something else in the circuit must be gumming things up.

To get an overall idea of how well your regulator does its job, plug your TV into a Variac. Then monitor the regulator's output voltage as you vary the line voltage from 90- to 125-volts AC, the usual range of line-voltage variation. If



JACK DARR
SERVICE EDITOR

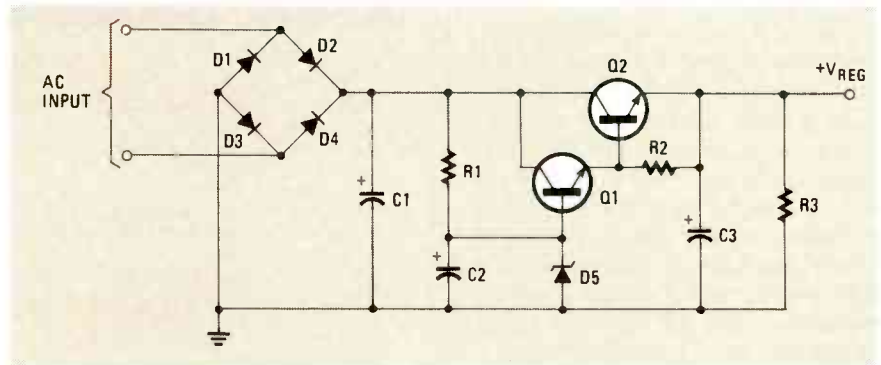

FIG. 1

your regulator holds the voltage constant over the whole range—connected to the load or not—it's probably good, so your troubles must be elsewhere!

However, if the regulator follows the line-voltage variations, your trouble is in the regulator circuit, so you'll have to troubleshoot it. And that means you'll have to know how it works.

Any voltage regulator—discrete or integrated—is really quite simple. It uses a power transistor as a "pass element," and a small-signal transistor as a "sense" element. The sense element monitors the output voltage, and if that voltage drops below a reference value, the sense transistor feeds more base current to the pass transistor, and that increases output voltage. Sophisticated power supplies disable output if the load tries to draw too much current.

As shown in Fig. 1, D5 is a Zener diode that provides a reference voltage for sense transistor Q1. That transistor controls the current fed to Q2's base, hence Q2's collector-emitter current, which indirectly controls output voltage.

To troubleshoot a 3-terminal regulator (like the ubiquitous 7805), about all you can do is measure input and output voltages. To troubleshoot a discrete voltage regulator, measure the DC voltage on every terminal of every transistor in the circuit. If a transistor has the same voltage on its base, emitter and collector (or any two of those terminals), it's almost certainly shorted! Replace it and retest the circuit. A leaky transistor can really mess up the whole circuit, so check all transistors for leakage. Leakage in the pass transistor is especially troublesome.

Symptoms

What would cause you to suspect a bad voltage regulator? Parasitic oscillation, too much gain, or too little gain can all be traced to a faulty voltage regulator. You're liable to get oscillation or too much gain if the regulator's output voltage is too high; on the other hand, too little gain might be caused by an output voltage that is too low. Try the Variac test; the output should remain steady; that's what the regulator is for!

Look for a component in the regulator that doesn't act in a normal fashion. For example, in normal operation the voltage at Q2's base should vary, but not the voltage at its emitter. If you suspect the pass transistor, check it, especially for shorts and leakage. You'll probably have to remove the transistor from the circuit to make a valid test.

Another problem you might run into is a bias resistor that has drifted off-value. Or the Zener diode (or other voltage reference) may have gone bad. How do you check a Zener diode? It's easy: just measure the voltage across it. If that voltage is not what the schematic calls for, the diode is probably bad. Replace it with one that has the correct voltage rating and measure the voltage across it again. You'll find Zener diodes with values ranging from a few volts all the way up to 115 volts. Be sure to get the correct value, or you'll have more problems than you started with.

Another potential problem component in a voltage regulator

is a voltage-dependent resistor (VDR). If the voltage across a VDR is correct, the VDR is probably OK, but if it's incorrect, try a new one.

All in all, regulators aren't too hard to fix. Use the procedures recommended above, and, above all, *think* about what the problem could be. You'll figure it out! R-E

SERVICE QUESTIONS

WHAT A YOKE!

In an RCA CTC-76, I've got what looks like a yoke problem, and it's intermittent, of course! The raster gives a keystone effect: narrow at the bottom; wide at the top. But it never stays on screen long enough to trace it. Rapping the chassis above PW400, which is the motherboard for the vertical and horizontal circuit boards, makes it disappear. I soldered all of the mounting points; we had trouble with bad grounds in several of those chassis. No luck. One

symptom guide suggests it may be R404, a 100K resistor in the base circuit of the error amp, Q404. That resistor is a flameproof type, and I always thought that those were supposed to open—not change in value or go intermittent! What do you think?—P. H., Herndon VA

I've never seen any part that *couldn't* be intermittent! Try replacing it and see what happens!

SIMPLE CURE FOR BURNT RESISTOR?

I've got a Sears 564.417700400. Resistor R250 burns up as soon as power is applied to the set. I've replaced several parts without help. Any ideas?—H. J., Castalia, OH

Yes. A resistor burns up because there's too much current flowing through it. Since it burns up before anything else has a chance to warm up and draw current, it probably has the full B+ across it, so the short must be on the load side. Maybe it's a solder-bridge, or even a wiring short somewhere. In any event, the cause of the problem should be easy to find. R-E

Put Your Electronic Skills to Work UNDERWATER!

BECOME A ROBOT VEHICLE PILOT/TECHNICIAN

Accredited by NATTS
Approved for Training of Veterans
Approved for Various Loan & Grant Programs

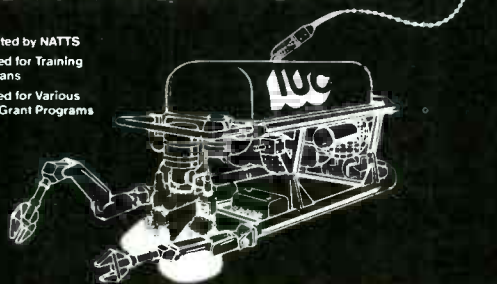

HIGH PAY—WORLDWIDE TRAVEL
Call or Write Today for FREE BROCHURE
CALL (212) 885-0600

UNDERWATER VEHICLE TRAINING CENTER
10046 CHICKASAW, HOUSTON, TX 77041
IN TEXAS CALL: 713-690-0405, TELEX 4620684

CIRCLE 280 ON FREE INFORMATION CARD

NEW Test Equipment from



Model 202 Function Generator

- 0.02 Hz to 200 kHz Function Generator
- Sine, Square, Triangle Waveforms
- Variable DC offset
- Variable 600Ω output
- TTL output
- External Sweep Mode

\$239.00

Model 1010 Oscilloscope

- Bench/Portable
- Low Power
- 10 MHz bandwidth
- 10 mV sensitivity

\$385.00



Model 603 Multimeter

- Bench/Portable
- 3½-digit 0.5" LED
- 0.25% basic accuracy
- 29 ranges
- Battery or Mains (AC adaptor) operation
- Supplied with test leads

\$175.00

Model 601 Multimeter

- Bench/Portable
- 3½-digit 0.5" LCD
- 0.1% basic accuracy
- 29 ranges
- Battery life typically >2000 hours
- Complete with batteries and test leads

\$215.00

Model 604 Multimeter

- Bench/Portable
- 3½-digit 0.5" LCD
- 0.25% basic accuracy
- 29 ranges
- Battery life typically >3000 hours
- Complete with batteries and test leads

\$195.00

Send for a copy of our FREE Electronics catalog

Call for complete specifications, accessories and order information.

w.s. JENKS & Son



1933 Montana Ave. NE
Washington DC 20002
(202) 529-6020

TOLL-FREE

1-800-638-6405

CIRCLE 66 ON FREE INFORMATION CARD

ANTIQUÉ RADIOS



RICHARD D. FITCH
CONTRIBUTING EDITOR

Early radio history

LAST TIME, WE BEGAN OUR LOOK AT THE early history of radio. This month we'll move into the 20th century and finish up that discussion.

The 20th century

There were many important inventions in the early part of this century. Crystal detectors—the first semiconductor diodes—were invented in 1906. The two-electrode tube was invented by Fleming (in England, where the device was, and still is, known as a valve) in 1904, and the triode (also called an audion) was invented by de Forest in this country in 1906. Actually, neither Fleming nor de Forest invented the first electronic tube. Sir William Crookes, a British electrical engineer, built an experimental tube in 1870. There were probably ten experimental tubes that preceded the Fleming valve, although the names of their inventors are lost forever. So, in the minds of many, Fleming receives credit for being first.

The United States Navy was one early radio pioneer. As far back as 1907 the USN had a radio station at Anacostia. Music and official messages were broadcast to the U.S. fleet on world tour in 1907. However, the Navy had been communicating with amateurs for many years, possibly as far back as 1900–1902.

Regular broadcast stations were a reality in Europe before they were in the U. S. Radio broadcasting was demonstrated at the Dutch Trade Fair in 1919. Many radio components had to be imported.

The roaring '20's

Before 1920, amateurs and ex-

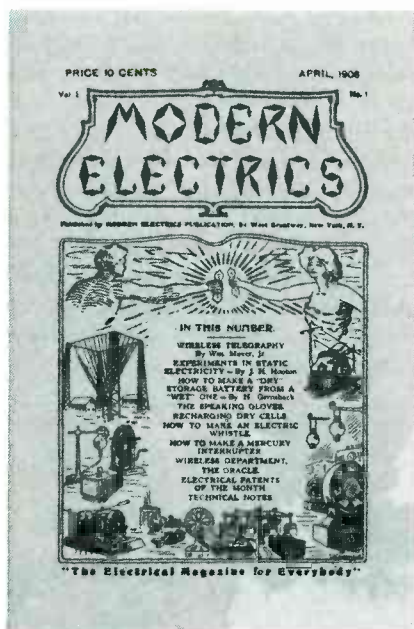

FIG. 1

perimenters always built their own radios. They talked, listened, or both to anyone who was on the air. Imagine the thrill of an early experimenter when he made contact with another experimenter, or heard a foreign broadcast. Kids who grow up these days taking radio and TV for granted can hardly appreciate that thrill.

I think it's fair to say that broadcast radio got its biggest boost in the 1920's, when Westinghouse station KDKA in Pittsburg broadcast election results. Of course, irregular broadcasts were already present, else there would have been no need for a commercial station. Before those historic broadcasts, many radios were purchased just to hear music broadcast by Dr. Conrad.

By the 1930's regular broadcasts

were well established. Many of the technical problems that had plagued early broadcast radio were being eliminated. Radio was well commercialized, and politicians were beginning to recognize that radio was a powerful propaganda medium.

Technical innovations

By 1921 alternatives to the inevitably annoying earphones were found. For example, a megaphone was placed over an earphone, and—instant loudspeaker. Improvements in tube construction did much for the quality of both transmitters and receivers. Also, power increased throughout the 1920's, and a dramatic improvement in microphone quality also helped signal quality. The importance of acoustics in the station's studio was recognized and given as much importance as purely electronic matters.

At the receiving end, the automatic volume control (AVC) circuit made its appearance. And the increased use of standard AC power was a big help to radio manufacturers. Problems with hum were overcome, and more and more sets developed all of the required voltages (A, B, and C supplies) from the standard "light socket."

Oldtimers tell me that radio stations had to go off the air when an S.O.S., or other emergency, was broadcast from a ship at sea. Those stations had to monitor ship traffic on nearby frequencies so that their regular broadcasts wouldn't interfere.

Regulating agencies

Arbitrating interference prob-

COMPUTER DIGEST

VOL. 3 NO. 3 March 1986

A NEW KIND OF MAGAZINE FOR ELECTRONICS PROFESSIONALS

ALL ABOUT PRINTERS

Everything You Always Wanted To Know...



FREQUENCY COUNTER FOR THE C-64

Using Your Light Pen As A Tachometer.

BUILD THE GRAFEX-32

Part 2 Of This Hi-Res Graphics Adapter.

CONTENTS

Vol. 3 No. 3

March 1986

8 All About Printers

If you have any questions about printers, chances are that you'll find the answers here. **Herb Friedman**

12 Frequency Counter For The C-64

Did you build the light pen project we offered a few months ago? Here's an unusual application for it. **Ralph R. Neal**

13 Build The Grafex-32

Here's the second part of this three-part article on a high-resolution graphics adapter for your Apple II. **Ray Dahlby**

3 Editorial

4 Letters

4 Computer Products

7 Software Review

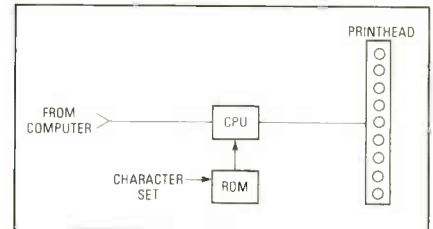

See Page 8

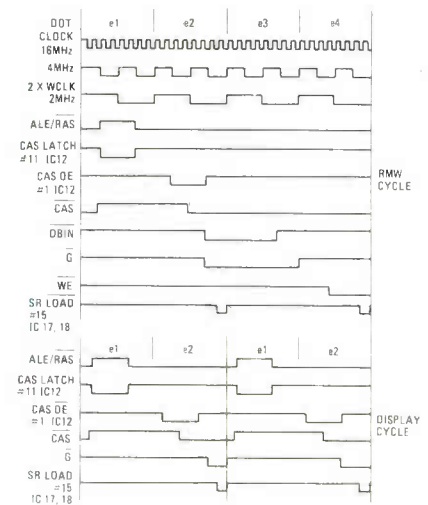

See Page 14

ON THE COVER

Hold the cover of this issue to your ear. Do you hear anything? Well, maybe the new P5 Printer from NEC really isn't that quiet, but at 48 dba in the quiet mode, it's got to impress you! See page 8 for more printer info.

COMING NEXT MONTH

What's actually required in the way of preventive maintenance for your computer? It's all spelled out in an informative article. We'll have an article on Packet Radio. And you'll find part 3, the finale, for the Grafex-32.

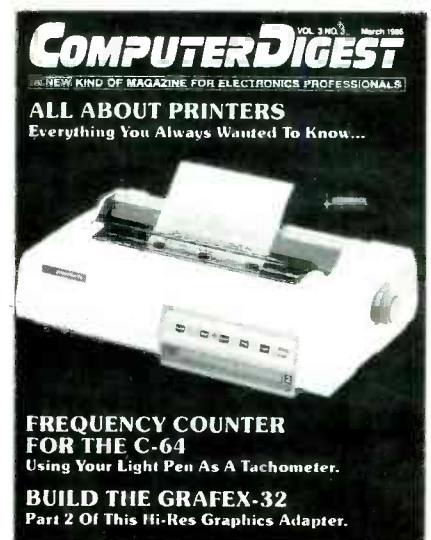

EDITORIAL

You've got to sacrifice...

■A friend of mine recently put his old IBM Selectric out to pasture and bought his first computer to use for word processing. He got a keyboard, a monitor, a printer and a modem along with a dual-disk drive. Now he was all set. As a professional author, he could do all his inputting on the computer, get a hard-copy printout, and shoot the copy in via modem to his publisher. His output increased, and he was very happy about the whole thing.

His wife, like so many people who aren't familiar with computers, actually resented this electro-mechanical interloper. All she knew about computers was that they were good for "playing games" and this one wasn't even used for playing games. She saw absolutely no value in the computer for herself. No value whatever.

One morning, she was on the phone with a friend who offered to give her a new and lengthy recipe. "Wait," she said, "I'll get a pencil and write it down."

Her friend, now faced with a long period of slowly reciting a dull recipe spoon-by-spoon over the phone, asked "Doesn't your husband have a computer?" She said he did, but she didn't know how to use it. The friend came over at once.

It took a quick call to my friend at his office to get the necessary password and some simple instructions, and they went into the room where the computer was, turned it on and booted up. "When the phone rings, just push this, okay?" and the friend left.

A minute later, the phone rang, the button was pressed, and the printer ran off the recipe. The last line read "Now pick up the phone." My friend's wife did so, and was told by her friend to wait, she'd be right over.

A lot of practical information was exchanged, and now my friend's wife sees the computer more as a friend than an enemy. She's got a bookful of her pet recipes stored on disk. On another disk she's got the kids' medical and school records. She keeps records of periodic car maintenance, and the computer has made her so efficient, she doesn't know how she ever got along without it until now.

A lot of the advertisers talk about their computers being "user friendly." But before anybody—or anything—can be friendly, it's got to be introduced.

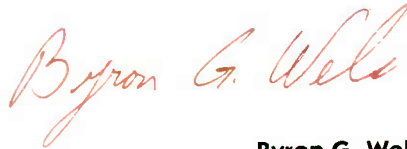

Byron G. Wels
Editor

COMPUTER DIGEST

M. Harvey Gernsback,
editor-in-chief, emeritus

Larry Steckler, EHF, CET: publisher &
editor in chief

Art Kleiman, editorial director

Byron G. Wels, editor

Brian C. Fenton, managing editor

Carl Laron, associate editor

Robert A. Young, assistant editor

Ruby M. Yee, production director

Karen Tucker,

production advertising

Robert A. W. Lowndes,

production associate

Geoffrey S. Weil,

production assistant

Andre Duzant, Technical Illustrator

Jacqueline P. Cheeseboro

circulation director

Arline R. Fishman,

advertising director

Gernsback Publications, Inc.

500-B Bi-County Blvd.,

Farmingdale, NY 11735

516-293-3000

President: Larry Steckler

Vice President: Cathy Steckler

ADVERTISING SALES 516-293-3000

Larry Steckler

Publisher

NATIONAL SALES

Joe Shere

1507 Bonnie Doone Terrace

Corona Del Mar, CA 92625

714-760-8967

ComputerDigest is published monthly as an insert in Radio-Electronics magazine by Gernsback Publications, Inc., 500-B Bi-County Blvd., Farmingdale, N.Y. 11735. Second-Class Postage Paid at New York, N.Y. and additional mailing offices. Copyright © 1986 Gernsback Publications, Inc. All rights reserved. Printed in U.S.A.

A stamped self-addressed envelope must accompany all submitted manuscripts and/or artwork or photographs if their return is desired should they be rejected. We disclaim any responsibility for the loss or damage of manuscripts and/or artwork or photographs while in our possession or otherwise.

R-E Books Admart

Rates: Ads are 2 1/4" x 2 7/8". One insertion \$825. Six insertions \$800. Twelve insertions \$775. each. Closing date same as regular rate card. Send order with remittance to **Books Admart**, Radio Electronics Magazine, 200 Park Avenue South, New York, New York 10003. Direct telephone inquiries to Arline Fishman, area code-212-777-6400. **Only 100% Book ads are accepted for this Admart.**

CONFIDENTIAL FREQUENCY LIST, 6th Edition

Latest available information on the most interesting communications stations operating on the short-wave bands. Includes SLB's, Phonetic Alphabet Stations, Numbers Stations, Military, Police, FBI, Government Agencies and more. 304 pages, 6 x 9 inches. Get your own copy for \$13.95 plus \$1 postage in USA. **ELECTRONIC TECHNOLOGY TODAY INC., PO Box 240, Massapequa Park NY 11762-0240.**

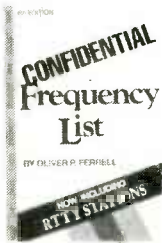

IC PROJECTS FOR BEGINNERS

IC Projects for Beginners



Soft cover; variety of projects built around IC's covering radio and audio projects such as a solar radio and a miniature receiver, plus an audio generator, interval timer, mixer amplifier and more. \$5.00 plus \$1 postage in USA. **ELECTRONIC TECHNOLOGY TODAY INC., PO Box 240, Massapequa Park, NY 11762-0240.**

32 ELECTRONIC POWER SUPPLY PROJECTS

Soft cover; 291 pages of practical DC circuit applications for a wide variety of hobby and experimental purposes! Circuits range from the very simple (like a half-wave supply) to more advanced units (like a 12-volt inverter). \$10.95 plus \$1 postage in USA. **ELECTRONIC TECHNOLOGY TODAY INC., PO Box 240, Massapequa Park, NY 11762-0240.**

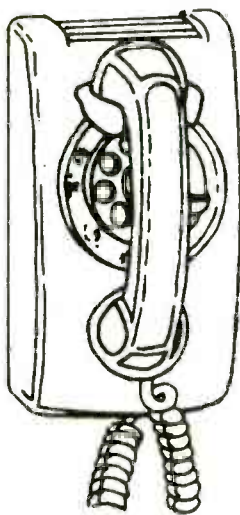

CALL NOW AND RESERVE YOUR SPACE

- 6 x rate \$800.00 per each insertion.
- Reaches 225,379 readers.
- Fast reader service cycle.
- Short lead time for the placement of ads.

Call 212-777-6400 to reserve space. Ask for Arline Fishman. Limited number of pages available. Mail materials to: **Books Admart, RADIO-ELECTRONICS, 200 Park Ave. South, New York, NY 10003.**

LINEAR IC EQUIVALENTS & PIN CONNECTIONS

Linear IC Equivalents and Pin Connections

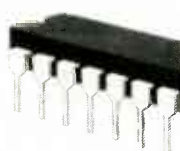

Shows equivalents & pin connections of a popular user-oriented selection of European, American and Japanese linear IC's. 320 pages, 8 x 10 inches. \$13.50 postpaid in USA. **ELECTRONIC TECHNOLOGY TODAY INC., PO Box 240, Massapequa Park, New York 11762-0240.**

WHITE'S RADIO LOG



An up-to-date directory of North American AM, FM and TV stations including special section on world-wide shortwave stations. 136 pages, 5 1/2 x 7 1/2 inches, soft cover. \$4.95 plus \$1 postage in USA. **ELECTRONIC TECHNOLOGY TODAY INC., PO Box 240, Massapequa Park, NY 11762-0240.**

DIGITAL IC EQUIVALENTS & PIN CONNECTIONS

Digital IC Equivalents and Pin Connections

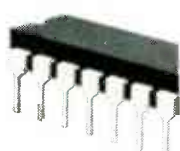

Shows equivalents & pin connections of a popular user-oriented selection of European, American and Japanese digital IC's. 256 pages, 8 x 10 inches. \$13.50 postpaid in USA. **ELECTRONIC TECHNOLOGY TODAY INC., PO Box 240, Massapequa Park, New York 11762-0240.**

103 PROJECTS FOR ELECTRONICS EXPERIMENTERS

Soft cover; 308 pages of practical, proven plans for the electronics hobbyist...circuits, converters, amplifiers, synthesizers, optoelectronics, power supplies and more. Written and designed by Forrest M. Mims, III. \$11.50 plus \$1 postage in USA. **ELECTRONIC TECHNOLOGY TODAY INC., PO Box 240, Massapequa Park, NY 11762-0240.**



SOFTWARE REVIEW

The Little Black Book.

■Actually, there would really be no need for this product... No need at all. Provided that you could as easily slip your entire computer into your breast pocket. But short of that, you're going to find *The Little Black Book* from Cygnet Technologies (1296 Lawrence Station Road, Sunnyvale, CA 94089 (800) 621-4292) the handiest peripheral you've bought for your computer since you decided to add a monitor!

This is an idea whose time has come.

Chances are that one of the first things you thought to do was put your telephone directory into your computer. Now you can run a printout of that directory on ordinary computer printout paper, cut on the dotted lines, and staple the info into this 400-entry directory which fits in a shirt pocket. Lose it, and all you need to do is print out a new one. Each of the entries offers name, address, phone number and notes; you can define up to 30 entry categories and you can use multiple entries for cross-referencing. Let's see you do *that* with your ordinary address book!

You say you aren't satisfied? You say you want more for your money? Tell you what we're gonna do. In addition to printing out your personal telephone directory, the software will—get this—automatically dial telephone numbers including access codes to your own long-distance dialing system! The optional dialer board is available at an additional cost of \$70.

Let's be practical. An executive on-the-go will certainly need one of these, but when you hear about some of the applications to which they're being put, you wonder how business ever got along without them. Take the New York based sales manager with a staff of far-flung salesmen all over the country. He simply bought additional book covers, one for each salesman, and has his secretary update the regional leads that come in each month. These are sent to the men in the field who add them to their own books.

The system, complete with a nicely packaged book cover, the software, all you need, works with IBM's and compatibles, Lotus 1, 2 and 3, Symphony, and most PC/DOS programs. It's yours for only \$50. That's right, I said fifty bucks.

Uniform

For the most part, the oft-occurring changeover from CP/M to MS-DOS machines is a smooth one. One reason for that is the fact that most of the popular software for the older format is also available for the IBM and its compatibles. In fact, the data files created by the CP/M versions of word processors, spreadsheets, data bases and the like are almost always compatible with the MS-DOS versions of that

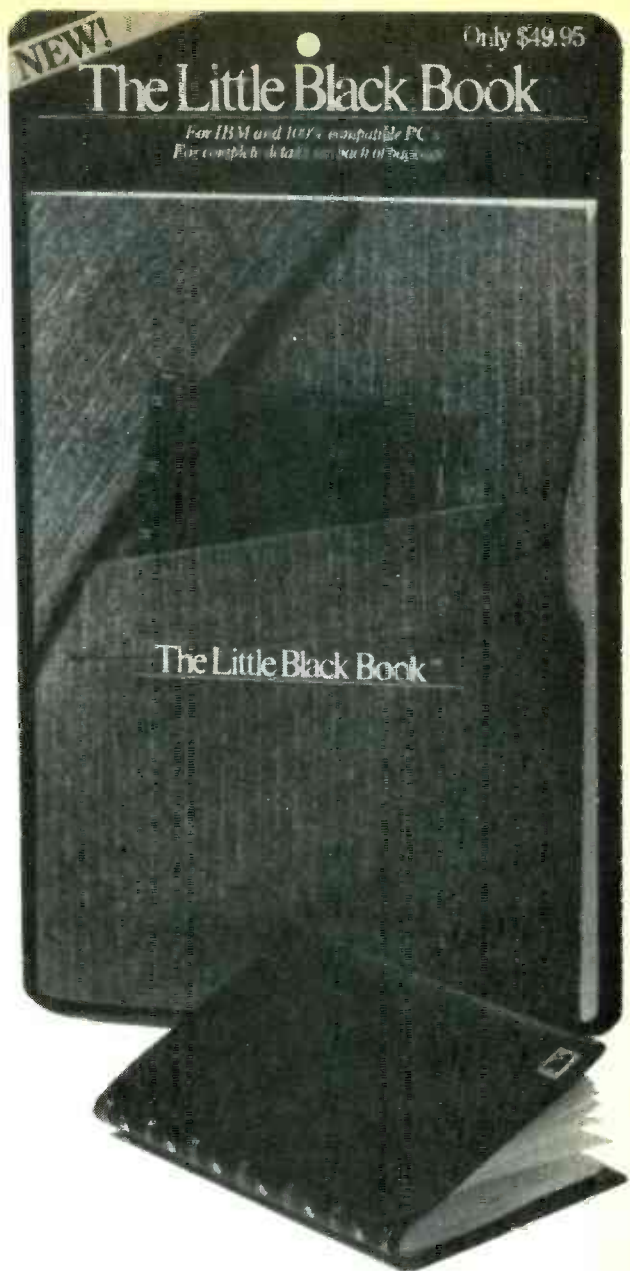

software. But, the disk formats are not.

In the past, the process of transferring your CP/M- software generated data files to MS-DOS disks has been a tedious and primitive one. Now, thanks to a new piece of software, that job is as simple as inserting your CP/M disk into your IBM's drive.

That new software, called Uniform, enables your MS-DOS machine to directly read and write disks from almost any of the popular CP/M formats, and to initialize a blank disk in the CP/M format of your choice. That means data files created by a CP/M machine can be used directly by an MS-DOS machine and vice-versa.

The software is easy to use; menus, prompts and easy-to-understand messages guide you through. Once invoked to select a disk format, you simply use the MS-DOS commands (COPY, etc.) and software with which you are familiar. Also, no modification of your hardware is needed.

For more information, contact Micro Solutions, Inc.
125 S. Fourth Street, DeKalb, IL 60115. ◀▶

ALL ABOUT PRINTERS

What you see may NOT be what you print!

Herb Friedman

■With few exceptions printers rarely are 100% compatible with any modern personal computer. Even when the printer has the same marque as the computer it's a good bet it won't print all the characters and symbols shown on the screen. Manufacturers often upgrade or modify the characteristics of their latest models to accommodate the features of the most recent software or hardware fad. While every printer must print the ASCII characters represented by ASCII codes 32 through 126—those we call "the character codes"—outside this range anything goes. Some computers create block graphics in response to ASCII codes above 126, others use the above-126 ASCII codes for a separate Italics font, still others use the above-126 codes for a complete set of international characters and Greek and math symbols, and others use the codes for partial international character sets.

Then there are the ASCII codes below 32—what are called "the printer control codes." While the line feed (LF), carriage return (CR) and back space (BS) are virtually standard, the remaining codes are used for whatever the manufacturer selects: Some use them for conventional printer controls, others employ some of the under-32 codes for graphic symbols such as the four playing card suits, the international male and female symbols and musical notes; anything at all.

Few printer buyers realize that "What they see ain't what they print" until it's too late. For example, two of the most famous, best-selling printers cannot reproduce the graphics and characters above ASCII 126 produced by the IBM and IBM-compatible personal computers, although one printer can be retrofitted to provide some of the upper-ASCII characters. In the home-and family category, no known non-proprietary printer can reproduce all the graphics of the Commodore 64, and any conventional printer used with the Apple II family of computers must use shifted

graphics because the conventional Apple printer interface has a seven-bit printer output, which limits the ASCII codes to 126.

In order to get around inherent printer limitations and be able to reproduce any character or symbol, some of the very latest printer designs—such as certain models from Epson and Panasonic—provide a user RAM area in which the user can store user-created or custom-designed characters.

Characters in ROM

All matrix printers are controlled by a microprocessor. As shown in Figure 1, a simplified functional diagram of a matrix printer, the microprocessor receives either serial or parallel data from the computer which it compares with a character set stored in ROM. For each conventional ASCII code there is a matching character or control function stored in ROM. (The codes for which no ROM character is provided are generally ignored by the printer.) The microprocessor also controls the movement of the print

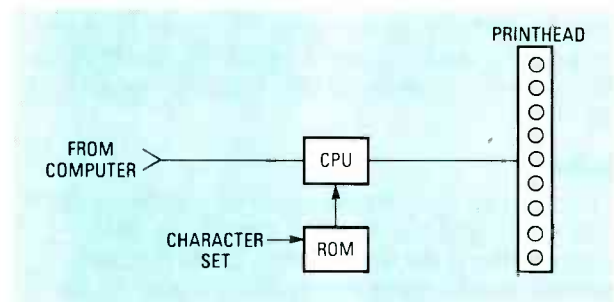

FIG. 1—THE BASIC MATRIX PRINTER drives the print head using a character set that is entirely within ROM. There is no way to modify the inherent characters or substitute user created characters.

head and the firing order of the print head wires that imprint the dots from which the characters are formed. The print head of most modern low cost printers employ 9 wires, of which up to 7 are used to create the characters (all 9 might be used for graphics). The extra wires are needed in order to create the descenders for lowercase characters such as the "p" "g" and "q." Figure 2 shows how the printer's CPU shifts from the seven upper to the seven lower wires in order to create upper and lower case characters in the Epson FX+ printer. Each character is created in a matrix 9 dots high and 6 dots wide. The dots represent the actual firing of the wires as the head is moved from left to right across the paper. If the head had only 7 wires the lowercase characters would be shifted upwards and lack descenders, as they did in the earliest of personal computer printers. Also note from Figure 2 that in some instances the dots are printed not in a column but on the "line(s)" between the column: It is possible to print a total of nine dots in a matrix only six dots wide. The very last column is not normally used for characters because it provides the spacing between characters.

The required ASCII code, head movement and the firing sequence of the wires for each character are programmed into the ROM along with the printer functions and cannot be changed. The printer will print only the character for which it is programmed even if the computer uses the same ASCII code for a different character, symbol or graphic. For example, if a particular printer has the same Italic character set as the Epson FX+ printer only the Italic characters will be generated by printer codes higher than 161. If the computer outputs an ASCII 234, which is the printer's lowercase Italic "j," the printer will print the "j" even though the same ASCII 234 code is recognized by the computer as the omega symbol. As far as the computer is concerned it is outputting the Omega symbol displayed on the screen, but as far as the printer is concerned the computer is sending an Italic "j."

But because a matrix printer's characters are created by individual dots it's possible to custom design any kind of character, symbol or graphic, even a complete character set from ASCII 00 to ASCII 256. All that's required is some way to supercede the ROM-based character set. This is accomplished, as shown in Figure 3, by driving the print head from a RAM buffer—user-programmable memory—rather than from the ROM. When the print is made the characters will be those of the programmable RAM rather than those of the ROM.

Ram permits the user to create a custom design for any or all ASCII codes, or to store one or more characters from the ROM character set and customize only specific ASCII codes. The CPU can either drive the matrix printhead from the ROM character set, or it can drive the print head from the RAM buffer. The ROM/RAM switching, the programming of RAM with custom characters, and the selection of ROM characters to be emulated in RAM are under software control, and can be entered either as direct statements, or as part of a BASIC program, or in certain select instances as a

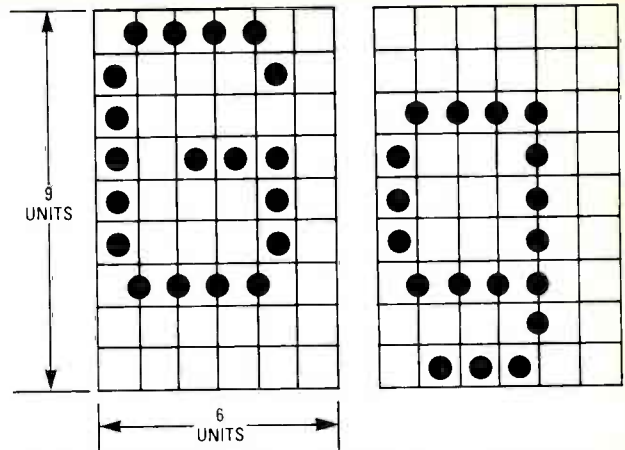

FIG. 2—THE CONVENTIONAL MATRIX PRINTER employs a 9-wire head even though only 7 wires are used for each character. The two "extra" wires are needed for lower case descenders, such as the "tail" shown on the lower case "g." Notice that the dots can be printed in a column or between columns. The extreme right hand column is left free for conventional characters because it provides the space between adjacent characters.

printer control code (the RAM/ROM switching) from within an applications program.

Let's illustrate printer programming using the ASCII 234 code previously discussed. If we wanted to substitute the Omega character for the Italic "j" we could program the entire ROM-based character set except for ASCII 234 to load into the RAM and then load a user-generated ASCII 234 representative of Omega (Ω) from the computer using a short BASIC program. As long as power to the printer wasn't interrupted it would print an Omega in response to an ASCII 234. Or, we could program the entire ROM character set from ASCII 00 through 126 into ROM, and then program only the custom designed ASCII 234. The printer would ignore all ASCII codes higher than 126 except for ASCII 234.

The user-designed characters must fit within what is called the "matrix" of the printer, which is simply a box representing all the dot positions that can be used to create a character. In the Epson FX+ printer the matrix is 9 x 11, meaning 9 vertical dots by 11 horizontal dots, as shown in Figure 4. Confused? No, there is no error in Figure 4. As we explained earlier in Figure 2, the dot matrix is 9 x 6, but dots can be printed between the columns; in effect, the matrix is 9 x 11. (Also as mentioned earlier, as a general rule the extreme right column is never used for the character because it is the minimum space needed between characters, but there is nothing to prevent the user from employing the column for special graphic effects or double-width characters.)

For example, Figure 5 shows how RAM programming can be used to create a customized font (type face) or individual characters. The FX+ printer is factory supplied with the Roman character set: The straight-sided characters we recognize as "computer printing." Figure 5A shows how the Roman "E" is generated: Notice the dots are located precisely within the matrix boxes. Let's assume that the user prefers to

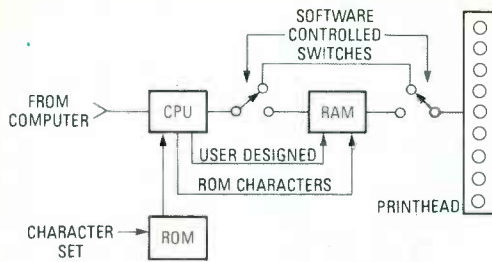

Fig. 3—A PRINTER THAT ACCOMODATES user-designed characters can print using either the ROM characters or from a RAM that is programmed with characters either downloaded from the computer or from the ROM. The RAM can accommodate any kind of ROM/download intermix.

have the printing more closely resemble the characters of a conventional typewriter, what is called NLQ, meaning "near letter quality." The distinction between the characters is serifs or rounded corners, and the user could custom design and program the printer with a substitute character set resembling conventional pica characters, such as the letter "E" shown in Figure 5B. If the user wanted to modify only the shape of the letters but not the numerals or punctuation symbols he could load the new upper and lower case letters into RAM along with the numerals and punctuation from the ROM roman character set. With the printer's CPU programmed to operate from RAM the printout would contain NLQ letters and Roman numerals and punctuation. A complete NLQ character set for letters, numerals and punctuation could be designed and loaded into RAM. It is even possible, as shown in Fig 5C, to program a graphic symbol such as the Omega.

Generally, we try to use whatever we can of the ROM characters. Designing a custom character set is not a one-evening project. The characters are created by a BASIC program: An individual character requires an attribute statement that positions the character in the 9 x 6 matrix, and a data line for each row. The data lines

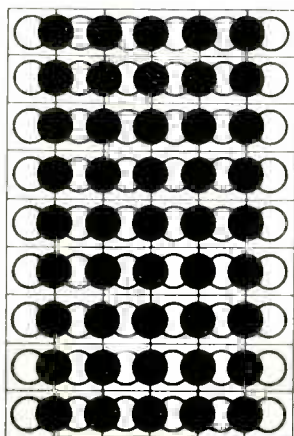
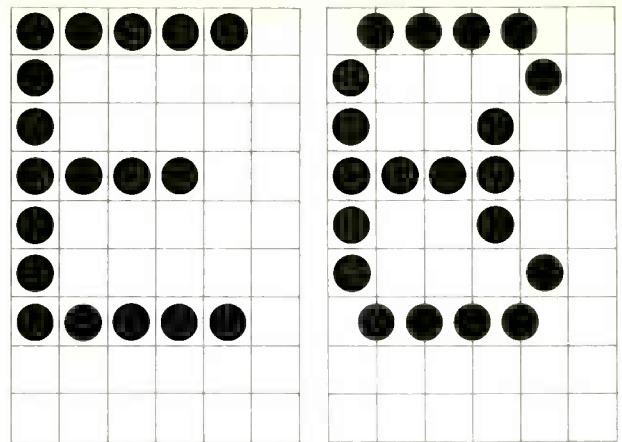
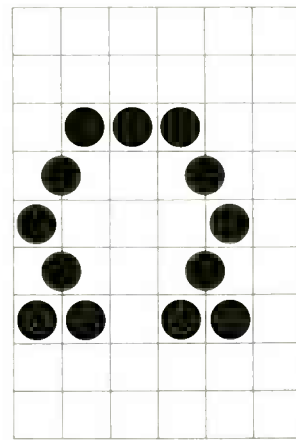

FIG. 4—CUSTOM-DESIGNED CHARACTERS are formed from a 9 x 6 matrix which actually provides 11 columns of dots. The characters are created by firing any of the indicated dots, however adjacent white and dark dots cannot be used; the printer will ignore an indicated dark dot if the immediate adjacent dot is white.



a

b



c

FIG. 5A—THE CONVENTIONAL ROMAN CHARACTER has straight sides and looks "computerized." This is how a dot matrix printer creates the Roman "E."

FIG. 5B—THE 'NLQ' TYPE CHARACTER—which resembles typewriter characters—can be created by the user and downloaded into RAM as a substitute for the Roman characters. This is how a user-created NLQ "pica" character might be created. Although full NLQ printing is attained by multistriking in such a way that the spaces between the dots are literally filled in, the basic character is created from individual dots.

FIG. 5C—SINCE THE CUSTOMIZED CHARACTERS are created from dots almost anything is possible. This is the pattern for Omega, the symbol we use to indicate resistance.

represent the byte value for each column of dots, and since there are nine possible columns for each character it would take considerable time and debugging to custom design no more than a handful of characters. It is probably less time and trouble to purchase a program that automatically downloads an NLQ or IBM-compatible character set(s).

While there is software available for some commonly-used non-programmable matrix printers that generates custom character sets through the printer's dot addressable function, the printing process itself tends to be s-l-o-w because each letter might require several passes of the print head. On the other hand, printers having custom characters programmed into RAM have no loss in throughput because the printer doesn't know whether it's printing ROM-based internal or RAM-based custom characters. ◀▶

Electronics Paperback Books

EXCITING OFFERINGS AT SPECIAL INTRODUCTORY PRICES



COMPUTER MUSIC PROJECTS \$7.50.
Shows how to use your home computer to produce electronic music. Many circuits. Mostly arranged free. (NO CHARGE for shipping)



AN INTRODUCTION TO COMPUTER PERIPHERALS \$6.50.
Describes and explains how to use a variety of different computer equipment in as non-technical a way as possible. (shipping FREE)



103 PROJECTS FOR ELECTRONIC EXPERIMENTERS from TAB book \$11.50, by Forrest M. Mims. More than 100 projects you'll want to build. (shipping FREE)

Linear IC Equivalents and Pin Connections



LINEAR IC EQUIVALENTS AND PIN CONNECTIONS \$12.50 (shipping free) 247 pages, 7 - 10 in shows equivs & pin connections for popular user oriented IC's

Digital IC Equivalents and Pin Connections



DIGITAL IC EQUIVALENTS AND PIN CONNECTIONS \$12.50 (shipping free) 312 pages, 7 - 10 in shows equivs & pin connections for popular user oriented IC's



32 ELECTRONIC POWER SUPPLY PROJECTS \$10.95. From TAB books. Provides power supply construction info for almost any application. (WE PAY for shipping)



THE PRE-BASIC BOOK \$7.50. A book on the BASIC programming for those who have not yet bought a computer as well as those who have trouble learning how to program. (shipping FREE)



FIRST BOOK OF DIODE CHARACTERISTICS \$5.00. Full interchangeable data and characteristics for thousands of diodes. (shipping FREE)

30 SOLDERLESS BREADBOARD PROJECTS, Reg. \$5.75, Now \$5.00.
30 SOLDERLESS BREADBOARD, Book 2, Reg. \$5.75, Now \$5.00.
ELEMENTS OF ELECTRONICS, AUDIO, Reg. \$9.00, Now \$7.50.
MINI-MATRIX BOARD PROJECTS, Reg. \$5.00, Now \$4.00

Save an extra \$2.00. Order both IC EQUIVALENTS editions and pay only \$23.00. We also include shipping free. You get a complete 2-volume library. (shipping FREE)

REMOTE CONTROL PROJECTS, Reg. \$5.00, Now \$4.50.
PROJECTS USING SOLAR CELLS, Reg. \$5.00, Now \$4.25.
DIGITAL IC PROJECTS, Reg. \$5.00, Now \$4.25.
ELECTRONIC PROJECTS FOR BEGINNERS, Reg. \$5.00, Now \$4.00



SECRETS OF THE COMMODORE 64 \$5.00. Masses of useful info and programming tips not found in any user's manual.

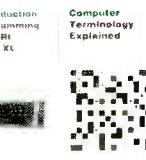

INTRO TO PROGRAMMING THE ATARI 600/800 XL \$5.00. Perfect complement to the Atari user's manual. Even shows how to use animated graphics



COMPUTER TECHNOLOGY EXPLAINED \$5.00. Explanations for computer terms often encountered. A dictionary for computer lingo.



INTRO TO Z-80 MACHINE CODE \$5.75. Speed up your programs. They may be harder to write, but it's worth learning how. Some demo programs are included.



ANTENNA PROJECTS \$5.00. Practical radio antenna designs that deliver good performance and are relatively simple and inexpensive to build.



WHITE'S RADIO LOG \$4.95. An up-to-date directory of AM, FM and TV stations, including a section on worldwide shortwave stations.



CONFIDENTIAL FREQUENCY LIST, 6th edition \$13.95. Latest info on usual and exotic shortwave broadcast and amateur stations.

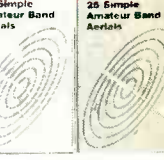

INTRODUCTION TO RADIO DXING \$5.00. How to optimize the reception of distant shortwave broadcast and amateur stations.

MICRO INTERFACING CIRCUITS—BOOK 1 \$5.00. Practical add-ons transform your computer into control or measurement equipment.

MICRO INTERFACING CIRCUITS—BOOK 2 \$5.00. Interfacing sound and speech generators, lenses, and optical sensors, motor controllers, and more.

Quality Paperbacks



HOW TO DESIGN ELECTRONIC PROJECTS \$4.50. Projects include rf amplifiers & converters, test equipment, receiver aids, tuners, receivers and more.

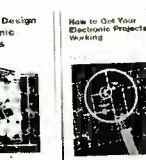

HOW TO GET YOUR ELECTRONIC PROJECTS WORKING \$5.00. How to find the faults in your projects, repair them and get them working.



DESIGN & MAKE YOUR OWN PC BOARDS \$5.75. Everything you need to know before you make printed-circuit boards for your projects.

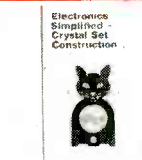

ELECTRONIC SECURITY DEVICES \$5.00. Three basic sections. Switch activated alarms, infrared & ultrasonic systems, smoke, gas, water detection.



INTERNATIONAL TRANSISTOR EQUIVALENTS \$7.50. Locates possible substitutes for a popular user-oriented selection of modern transistors. Japanese, European and American types.



PRACTICAL ELECTRONIC BUILDING BLOCKS, Book 1 \$5.75. Build the blocks and then combine them to form almost any custom project of your choice.



PRACTICAL ELECTRONIC BUILDING BLOCKS, Book 2 \$5.75. Amplifiers of all kinds to add to the circuits from Book 1 of this series.

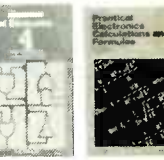

PRACTICAL ELECTRONIC CALCULATIONS AND FORMULAE \$7.50. A workshop manual that bridges the gap between complicated tech theory and cut and try.

ELECTRONIC SCIENCE PROJECTS \$5.75. Simple to complex, a group of projects with a strongly scientific flavor.

CRYSTAL SET CONSTRUCTION \$4.50. A variety of crystal radio receivers for the experimenter and hobbyist.

Affordable Prices



20 PROGRAMS FOR THE ZX SPECTRUM & 16K ZX81 \$5.00. All programs run on both machines. Include flow charts and info on how to modify to run on other computers.

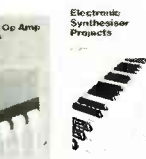

MODERN OP-AMP PROJECTS \$5.00. Includes a Slide Timer, AF Signal Gen, Mike Pre-amp, Scratch Filter, and much more.



ELECTRONIC SYNTHESIZER PROJECTS \$4.50. How to assemble the elements of a synthesizer, and then put them all together.



COUNTER DRIVER & NUMERICAL DISPLAY PROJECTS \$5.00. Timing circuits to fit just about every application. Required for every experimenter.

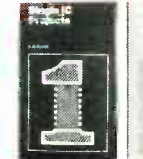

SINGLE IC PROJECTS \$4.25. All projects in this book are based on one IC and are simple to construct. Great way to get started with IC's.



POPULAR ELECTRONIC PROJECTS \$4.75. A collection of a wide range of electronic projects and circuits for the experimenter.



IC PROJECTS FOR BEGINNERS \$5.00. Written especially for the less experienced experimenter. Complete parts layouts and wiring diagrams.



POPULAR ELECTRONIC CIRCUITS, Book 1 \$5.75. More circuits for hobbyists. Audio, radio, test, music, household and more.

ELECTRONIC MUSIC AND CREATIVE TAPE RECORDING \$5.00. Shows how you can make electronic music at home with simple and inexpensive equip.

COUNTER DRIVER & NUMERICAL DISPLAY PROJECTS \$4.50. Numerical indicator devices make it easy to count, divide and display.

CHECK OFF THE BOOKS YOU WANT

ELECTRONIC TECHNOLOGY TODAY INC.
P.O. Box 240, Massapequa Park, NY 11762-0240

Name _____

Address _____

City _____ State _____ Zip _____

*Canadian Shipping (\$1.50 1st two books 50c ea. additional)

Number of books ordered

Total Price of Books \$ _____

Sales Tax (NY State Residents) \$ _____

*Shipping in U.S. only (\$1.00 1st two books, 40c ea additional) \$ _____

TOTAL ENCLOSED \$ _____

RE 3-6

FREQUENCY COUNTER FOR YOUR C-64

A new use for your light pen.

Ralph Neal

■After building the light pen described in the June, 1985 edition of **ComputerDigest**, I began thinking of possible uses for it. One idea, was as an optical tachometer for measuring the speed of rotating objects such as fans or motors. The program presented here is the result. Using this program and a light pen compatible with the Commodore C-64, you can measure the rotational speed of most objects.

The program was originally written in Assembly Language and later converted to data statements to make the program easier to type into the computer. Unfortunately, there is one drawback to this. Without the source code, it is difficult to see how the program functions. However, we'll explain.

How the program works

If it were not for the fact that computers are very-fast adding machines, this system would only work at low frequencies. We take advantage of the computer's speed by having it count the number of times the light pen is activated per second. At the point where the second has ended, the program stops counting and displays the count to the screen for about two seconds. After this, all values are zeroed and the count begins again as sensed by the light pen.

Obviously, timing is everything if this system is to function properly. And all of the timing is accomplished by use of the Jiffy Clock, which is an interrupt-driven clock. The computer keeps a continuous count of the number of times interrupts occur and stores this count at memory locations 160 - 162. However, of these three memory locations, we are concerned only with location 162. This location is updated every 1/60th of a second. All we have to do to check to see if a second has passed, is compare this location with the number 60. When memory location 162 reaches 60, the program stops counting and jumps to a time-out subroutine. This subroutine continuously checks the same memory location (location 160) for a value of zero. This value will *only* be obtained after the count in memory location 162 has passed 255. Once the value in location 162 is equal to zero, the program

```
5 REM* OPTICAL TACHOMETER *
10 PRINT"Q"
20 POKE 53281,1
30 FOR I=32768 TO 32971
40 READ X
50 POKE I,X
60 NEXT I
70 SYS32768
80 DATA169,1,141,255,3,173
90 DATA24,208,9,2,141,24
100 DATA208,32,172,128,169,48
110 DATA141,255,4,141,0,5
120 DATA141,1,5,141,2,5
130 DATA141,3,5,169,72,141
140 DATA5,5,169,26,141,6
150 DATA5,169,0,133,162,162
160 DATA4,24,164,162,192,59
170 DATA176,109,32,150,128,189
180 DATA255,4,109,255,3,157
190 DATA255,4,201,58,208,234
200 DATA233,10,157,255,4,202
210 DATA189,255,4,105,0,157
220 DATA255,4,201,58,208,213
230 DATA233,10,157,255,4,202
240 DATA189,255,4,105,0,157
250 DATA255,4,201,58,208,195
260 DATA233,10,157,255,4,202
270 DATA189,255,4,105,0,157
280 DATA255,4,201,58,208,177
290 DATA233,10,157,255,4,202
300 DATA189,255,4,105,0,157
310 DATA255,4,201,58,208,159
320 DATA233,10,157,255,4,202
330 DATA173,0,220,41,16,208
340 DATA249,173,0,220,41,16
350 DATA240,249,96,165,162,208
360 DATA252,76,16,128,162,0
370 DATA189,186,128,157,50,4
380 DATA232,224,17,208,245,96
390 DATA70,82,69,81,85,69
400 DATA78,67,89,32,67,79
410 DATA85,78,84,69,82,96
```

READY.

jumps to the start and is again ready to record events detected by the light pen.

First connect the light pen to joystick port 2. Then turn on the computer and load the program listed. When run, the program should clear the screen and turn the background of the monitor to white. A simple test to check out the program, is to place the light pen against the screen of the monitor. A value of 60 should appear on the screen if the program is functioning properly. (The value may fluctuate between 59 and 61 on some monitors.)

There are some limitations to this program. From tests conducted, it would appear that the limiting readable frequencies are about 10,000Hz. At this frequency, the optical tachometer reads about 9650Hz, some 450Hz from true value. ◀▶

BUILD THE GRAFEX-32 PART 2

RAY DAHLBY

This article, begun in February is continued here.

A 7220 display cycle requires 2-2Xwclk cycles and a RMW cycle requires 4-2Xwclk cycles. The sequence of events which takes place during a RMW cycle is outlined below. The four 2Xwclk intervals are referred to as e1, e2, e3, and e4 as per the timing diagram, Figure 3.

The intervals description follows:

e1—The 7220 begins to output the display memory address on the 16 AD lines; ALE goes low to indicate this address is valid. This signal (also called RAS) strobes the low 8 address bits into the display memory and latches the high 8 address bits into the CAS latch, IC12.

e2—The 7220 tri-states the AD lines and DBIN goes low to indicate that a RMW cycle is in progress. The CAS latch OE pin is brought low to present the 8 column address bits to the display memory and then, the CAS line is brought low to strobe this address into

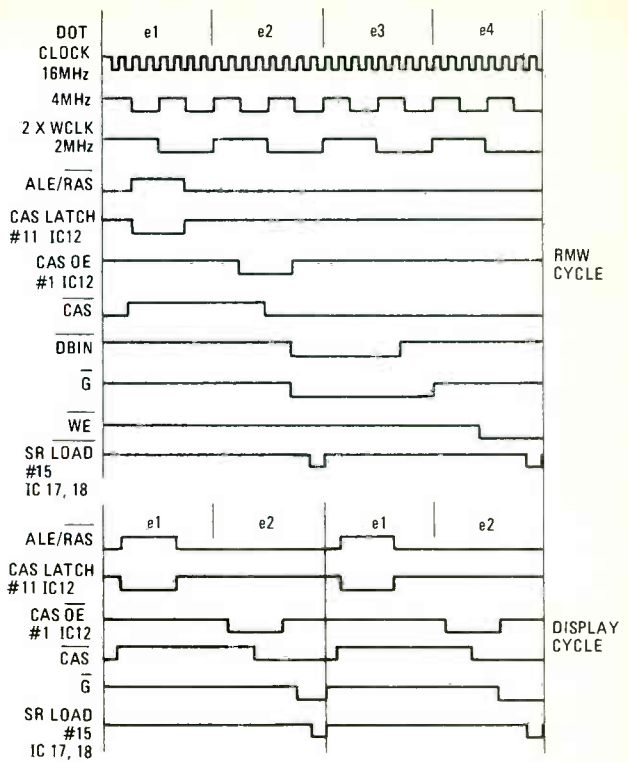
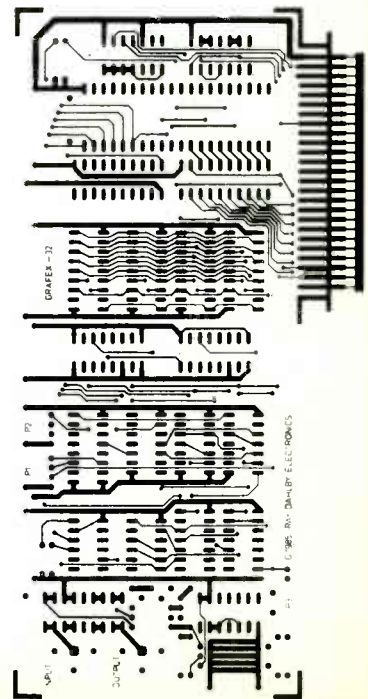
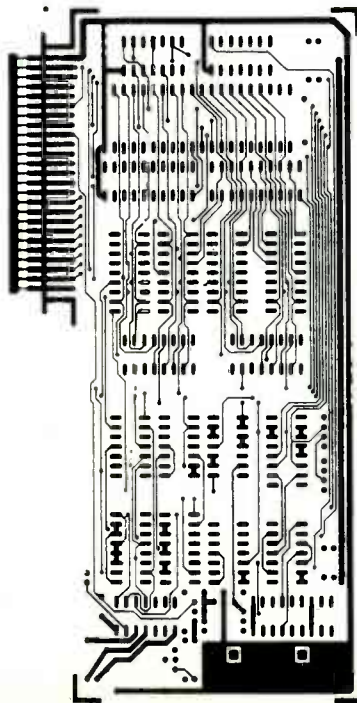

FIG. 3—TIMING DIAGRAM illustrates timing steps and sequences. See text for further information.

the display RAM chips. The G pin of the memory is brought low to allow the read data to be presented to the 7220. The read data is loaded into the video shift registers.

e3—The 7220 reads the 16 bit data from the display

FIG. 4—PRINTED CIRCUIT BOARD is shown half size for those who wish to make their own. Due to space restrictions, board had to be reduced 50%. Be sure to have these drawings photographically enlarged 200% before making board. Component side is shown at left.



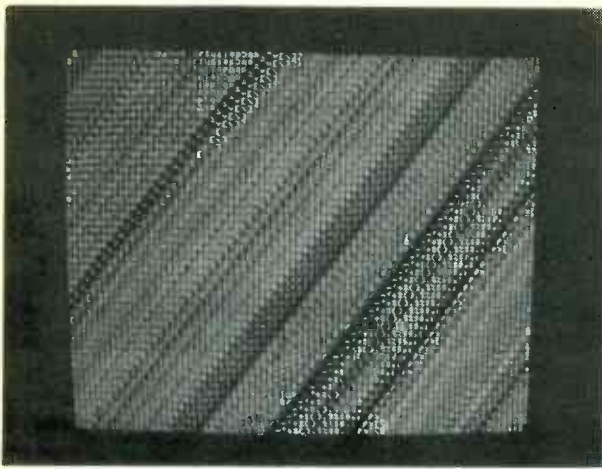

BARBERPOLE EFFECT OF 80 columns by 50 rows of text. The character set is made from a 5 x 7 dot matrix in an 8 x 8 box. This set includes the complete 128 character ASCII set.

memory and performs the modifications.

e4—The G pin of the memory is brought high to tri-state the RAM data lines, the 7220 presents its modified data onto the AD lines, the memory WE is brought low to write the modified data back into the display memory. The modified data is loaded into the video shift registers.

The two 2Xwc1k intervals which make up a display cycle are outlined below. Again, e1 and e2 refer to the 2Xwc1k intervals labelled on the timing diagram.

e1—The 7220 begins to output the display memory address on the 16 AD lines; ALE goes low to indicate this address is valid. This signal strobes the low 8 address bits into the display memory and latches the high 8 address bits into the CAS latch, IC12.

e2—The 7220 tri-states the AD lines and DBIN stays high to indicate that a display cycle is in progress. The CAS latch OE pin is brought low to present the 8 column address bits to the display memory and then, the CAS line is brought low to strobe this address into the display RAM chips. The G pin of the display memory is brought low to allow the read data to be presented to the video shift registers. The read data is loaded into the video shift registers.

Notice that the video shift registers are loaded with new data every two 2Xwc1k interval regardless of whether the 7220 is executing a display cycle or a RMW cycle. In the case of a RMW cycle, the data loaded into the shift registers will not correspond to valid screen data and will cause visible glitches if the 7220 is allowed to access the screen RAM during active video intervals. The 7220 has a provision which allows RMW cycle to take place only during the blanked Vsync and Hsync intervals preventing a disturbed screen display while drawing is in progress. Although the video shift registers are still loaded during RMW operations, these cycles are restricted to the approximately 30% of the time when the screen is blanked, preventing the false data from being seen.

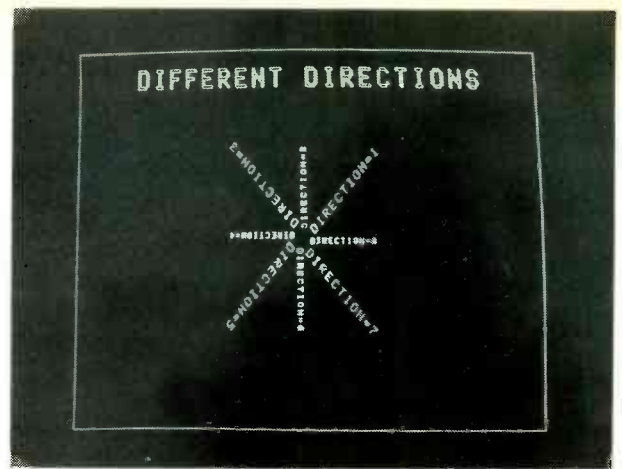

THE EIGHT DRAWING DIRECTIONS. The display was produced by writing the string "DIFFERENT DIRECTIONS" at a magnification factor of 2, then writing it again with the x and y starting position shifted by 1 pixel and the mode set to complement.

When two or more boards are installed in a system, they are daisy-chained together by means of the expansion connectors, P1 and P2. These connectors carry the 16 MHz dot clock and the 7220 video sync signals from the board designated to be the master, to the slave boards. The jumper on P3 is installed only on the board acting as the master. When initialized by software, the slave 7220's synchronize their timing with the master so that all of the 7220's run in phase with each other. In this way, three Grafex boards installed in a system can each drive one gun of an RGB color monitor. The composite sync is carried on the video for those monitors capable of accepting sync on the green input. RGB monitors having external synchronization inputs can be driven from one of the expansion connectors of a Grafex board. Specific information explaining the use of three Grafex boards with RGB monitors is included with the color software package available from my company. Please check with the source mentioned at the end of this article for price and delivery information. Figures 4 and 5 provide necessary information should you prefer to fabricate your own boards.

Programming the 7220

After power up, the 7220 must be initialized by a series of commands and parameters to configure it for the type of display desired. Usually, these commands and parameters are stored in a table which the initialization routine can refer to and then pass to the 7220.

The path for information flow between the host microprocessor and the 7220 is the first-in first-out (FIFO) buffer internal to the 7220. Commands and parameters are loaded into this buffer by the host and removed at the other end by the GDC's command processor. Care must be taken by the programmer to avoid overflowing the FIFO buffer with data faster than the GDC empties it. For this purpose, the GDC has a status register containing bits which indicate when the FIFO buffer is full or empty and also when data is ready

TABLE 1

Address	Read	Write	Video Relay
CON0	Status Register	Parameter	Apple Video Displayed
CON1	FIFO	Command	
CON2	Status Register	Parameter	Grafex Video Displayed
CON3	FIFO	Command	

to be read by the host microprocessor. Referring to Table 1, the status register can be seen to be mapped into the Apple's expansion slot area and can be read at any time. Other bits in this register indicate the state of the Vsync and Hsync video timing counters to allow smooth scrolling and other effects needing software synchronization to the video field rate.

The first command issued after power up is the Reset command. This command is interpreted by special hardware ahead of the FIFO to ensure that the internal registers, FIFO buffer, and command processor of the GDC are reset to their idle state prior to the initialization commands and parameters which follow. Normally, it is a good idea to check the status register for a FIFO FULL condition before each byte is output. On power up, the flags in the status register are not meaningful, so the RESET command must be issued before attempting to read the status register or load other commands and parameters into the GDC.

A typical initialization program is shown in Listing 1.

Listing 1

```

1 IO      EQU  $FE
2        ORG  $0300
3        LDA  ##F2      ;SLDT7
4        STA  IO
5        LDA  ##C0
6        STA  IO+1
7 INIT   LDX  #00
8 LOOP   LDA  TABLE1,X
9        LDY  TABLE2,X
10       STA  (IO),Y
11       INX
12       CFX  #30
13       BNE  LOOP
14       RTS
15 TABLE1 DFB  $00,$1F,$26,$04,$1A
           , $0B,$1E,$CB,$40,$6F,$47,$2B,$70,
           $00,$00,$00,$19,$4B,$00,$C0,$00,$
           46,$00,$7B,$FF,$FF,$23,$4C,$10,$6
           B
16 TABLE2 DFB  1,0,0,0,0,0,0,0,0,1
           ,1,0,1,0,0,0,0,1,0,0,0,1,0,1,0,0,
           1,1,0,1
    
```

GRAFEX-32 Power and Ground Pin-outs

	+5volts	ground
IC1	40	20
IC2	14	7
IC3	14	7
IC4	14	7
IC5	14	7
IC6	14	7
IC7	14	7
IC8	14	7
IC9	14	7
IC10	16	8
IC11	20	10
IC12	20	10
IC13	9	18
IC14	9	18
IC15	9	18
IC16	9	18
IC17	16	8
IC18	16	8
IC19	16	8
IC20	16	8

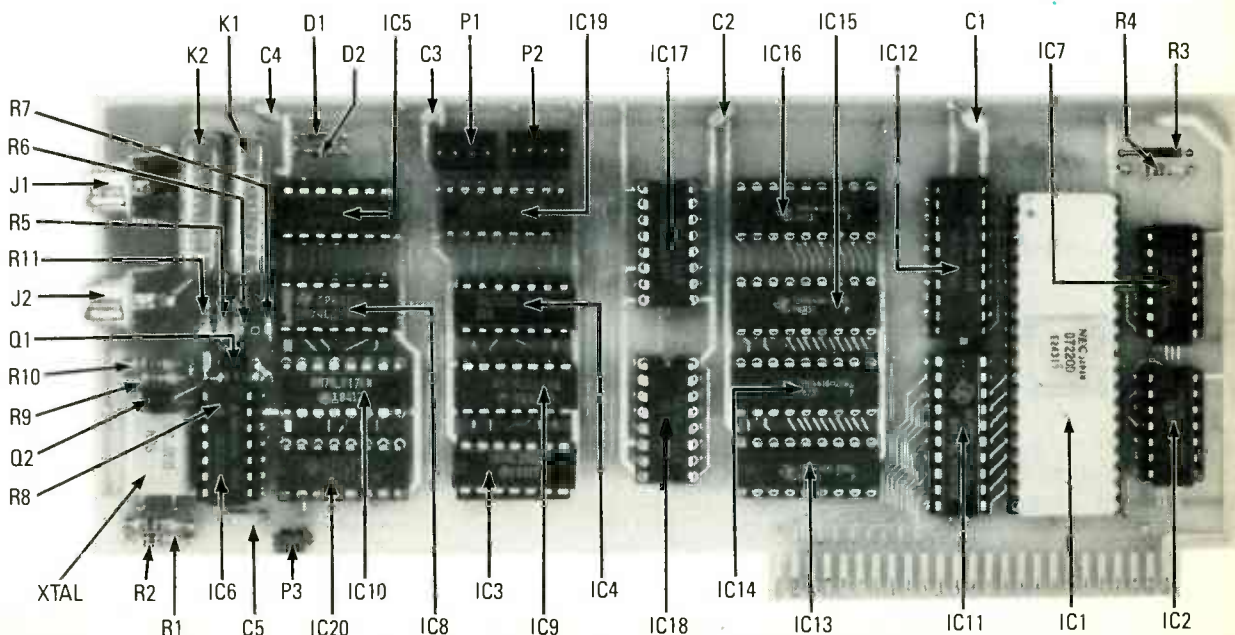

FIG. 5—PARTS PLACEMENT is shown above. No components are mounted on reverse side of board.

Listing II

```

:L
1 IO      EQU   $FE
2        ORG   $0300
3        LDA   #$F2      ;SLOT7
4        STA   IO
5        LDA   #$C0
6        STA   IO+1
7        JSR   FIFO      ;MAKE SURE FIFO IS EMPTY
8        LDY   #01
9        LDA   #$49      ;CURSOR COMMAND
10       STA   (IO),Y
11       DEY
12       LDA   #00
13       STA   (IO),Y
14       STA   (IO),Y
15       INY
16       LDA   #$4A      ;MASK COMMAND
17       STA   (IO),Y
18       DEY
19       LDA   #$FF
20       STA   (IO),Y
21       STA   (IO),Y
22       INY
23       LDA   #$0F      ;SYNC COMMAND
24       STA   (IO),Y
25       DEY
26       LDA   #$0F      ;FAST MODE
27       STA   (IO),Y
28       LDX   #$00
29 LOOP   LDY   #01
30       LDA   #$4C      ;FIGS COMMAND
31       STA   (IO),Y
32       DEY
33       LDA   #$02
34       STA   (IO),Y
35       LDA   #$FF
36       STA   (IO),Y
37       LDA   #$3F
38       STA   (IO),Y
39       INY
40       LDA   #$22      ;WDAT MODE
41       STA   (IO),Y
42       DEY
43       LDA   #$FF
44       STA   (IO),Y
45       STA   (IO),Y
46       JSR   FIFO      ;MAKE SURE FIFO IS EMPTY
47       INX
48       CPX   #$01      ;CHANGE TO #$04 FOR 128K
49       BNE   LOOP
50       RTS
51 FIFO   LDY   #00
52 WAIT   LDA   (IO),Y
53       AND   #$04
54       BEQ   WAIT
55       RTS

```

Table II
Video Parameters

Active Line = 40µs
HFP = 7µs
HBP = 12µs
HSYNC = 6µs
Total Line Time 64µs

Active lines per video field = 200 lines
VFP = 30 lines
VBP = 16 lines
Vsync = 16 lines
Total lines per field = 262 lines

Video field rate = 1/64µs × 262 lines) = 59.637 Hz

This sequence configures the GDC to generate 640 by 400 interlaced video with the video timing parameters given in Table II. The GDC is designated as master, dynamic RAM refresh is enabled, and transparent mode is selected (the GDC is allowed to draw only during blanked screen intervals). Also the entire screen is defined as a bit-mapped graphics area with the screen window set to the top of memory. When this program is run, the 7220 begins outputting video to the system

Listing III

```

:L
1 IO      EQU   $FE
2        ORG   $300
3        LDA   #$F2      ;SLOT7
4        STA   IO
5        LDA   #$C0
6        STA   IO+1
7        JSR   FIFO      ;MAKE SURE FIFO IS EMPTY
8        LDY   #01
9        LDA   #$23      ;WDAT MODE
10       STA   (IO),Y
11       LDA   #$78      ;PATTERN RAM
12       STA   (IO),Y
13       DEY
14       LDA   #$FF
15       STA   (IO),Y
16       STA   (IO),Y
17       INY
18       LDA   #$49      ;CURSOR COMMAND
19       STA   (IO),Y
20       DEY
21       LDA   #$B1
22       STA   (IO),Y
23       LDA   #$17
24       STA   (IO),Y
25       LDA   #$00
26       STA   (IO),Y
27       INY
28       LDA   #$4C      ;FIGS COMMAND
29       STA   (IO),Y
30       DEY
31       LDA   #$40
32       STA   (IO),Y
33       LDA   #$03
34       STA   (IO),Y
35       LDA   #$00
36       STA   (IO),Y
37       LDA   #$63
38       STA   (IO),Y
39       LDA   #$00
40       STA   (IO),Y
41       LDA   #$63
42       STA   (IO),Y
43       LDA   #$00
44       STA   (IO),Y
45       LDA   #$FF
46       STA   (IO),Y
47       LDA   #$3F
48       STA   (IO),Y
49       LDA   #$63
50       STA   (IO),Y
51       LDA   #$00
52       STA   (IO),Y
53       INY
54       LDA   #$6C      ;FIGD COMMAND
55       STA   (IO),Y
56       RTS
57 FIFO   LDY   #00
58 WAIT   LDA   (IO),Y
59       AND   #$04
60       BEQ   WAIT
61       RTS

```

CRT monitor from the random power-up data in the display memory.

A screen clear sequence is shown in Listing 2. This sequence clears the entire 32,768 bytes of display memory to zeroes in under 16 ms, or less than the time required for one video field. This routine can be modified to clear 128K bytes of display memory by changing the indicated line to: CPX #\$04.

A final sequence of commands and parameters, shown in Listing 3, draws a rectangle in the center of the screen with the dimensions of 100 vertical pixels by 100 horizontal pixels.

That's all the space for now. We'll conclude this article next month.

lems and other regulating functions were performed by the Department of Commerce, and, later, by the Federal Radio Commission (the FRC), the forerunner of our present-day FCC. The FRC was started by an act of Congress in 1927, and the FRC began life with a group of technically knowledgeable commissioners who had many problems with politicians who wanted to control—or abolish—the FRC. And the tremendous growth of radio meant that the FRC had all it could do just to keep up with technical problems.

Among its many other responsibilities, the FRC regulated the use of language that might be considered profane. To a degree, the FRC could punish persons or stations for infractions of the rules. Criminal violations were referred to the Department of Justice.

Cracking down on pirate (unlicensed) stations was another of the FRC's tasks. Dozens of pirate stations were creating interference with licensed stations. By the 1930's, the FRC was already handling hundreds of cases per week, all of which were related to radio regulations.

Stations were assigned their place on the dial according to several criteria, including type of programming and power output. For example, in 1921, the Department of Commerce assigned music and entertainment stations to 360 meters. Agricultural and meteorological (weather) reports were assigned to 485 meters. During the next few years, stations were assigned by their power output. Lower-powered stations were placed on the 230-330 meter band. Later, the broadcast band was lowered to 200 meters.

There were about 15,000 to 20,000 amateur radio operators (hams) operating in the United States in those early days. Those operators and experimenters were an asset to the industry as well as to the country, and the government always encouraged their efforts. Unfortunately, many of their contributions to the development of radio remain anonymous.

Patent-infringement suits were being solved in the 1930's, and that meant that more superheterodyne receivers could be built. Of

course, suits and bankruptcies continued on through the 1930's and into present times.

Other early influences

This column is devoted mostly to radio. But closely intertwined with the development of radio was, of course, TV. The earliest radio experimenters were just as interested in being able to send visual as aural messages. Some of those ideas go back as far as the 1700's, when experimenters believed that transmitting images would be easier than transmitting sound!

The editors of early radio publications deserve much credit for advancing the state of the radio art, as well as for fostering interest in radio. Actually, the radio magazines, and their learned editors, were probably the most reliable sources of information for early radio enthusiasts. Complete schematics, explanations of the latest circuits, photographs, and sources for parts were often published in those magazines.

In the early 1900's almost all home-built receivers were built from information contained in a radio magazine. With the coming of commercially-built sets, many of those magazines disappeared. Of course, not all radio publications fell by the wayside. And among the survivors were the publications by Hugo Gernsback. Starting with *Modern Electrics* (see Fig. 1) in 1908, *Radio Craft* in the 1920's, and *Gernsback's Educational Library*, in the 1930's, Gernsback's publications were, and still are, a vital source of information for radio enthusiasts and people interested in all facets of electronics.

Have and needs

I have sent many personal replies assisting fellow collectors. If you still need antique radio parts or information, try one of the following:

Antique Electronic Supply Co. (1725 W. University, Temple, Arizona 85281) is a good source of tubes, parts, and books. The Vestal Press Ltd., (Box 97, 320 N. Jensen Road, Vestal, New York 13850) also has a good supply of books and manuals. **R-E**

STUN GUN

49.95



Free holster with purchase.



EQUALIZER

- The ultimate non-lethal defense weapon.
- In five seconds can immobilize your attacker, even through heavy clothing.
- Discharges over forty thousand volts of electricity from a nine volt nickel-cadmium battery.
- \$49.95, Mass 5% sales tax, \$3.00 shipping and handling.

1-800-522-2636
FOR ORDERS ONLY
617-871-5611
FOR INFORMATION

Cameo Enterprises, Inc.
P.O. Box 63, Accord, MA 02018

CIRCLE 277 ON FREE INFORMATION CARD

Cash in on the Video-Cassette Boom! START YOUR OWN TV/VCR REPAIR BUSINESS at Home in Spare Time



Now it's easy for you to get into this money-making business. Be the person in demand by the millions of families who own videocassette recorders—the fastest-growing product in the home entertainment field. Train at home in your spare time for an exciting career as a TV/VCR Repair Specialist. Experts show you how to start small at home with low overhead. Later you can go after repair business from hotels, offices, hospitals and other companies who use TVs and VCRs in their daily operations.

Experts show you what to do, how to do it...guide you every step of the way!

Learn how to handle house calls and shop repairs—everything you need to know to get started fast. Tools are included with your course so you get "hands-on" practice as you follow your lessons step by step. Everything is explained in easy-to-understand language, but if there is ever anything in your lessons you don't understand, you can write or phone your instructor and you can count on getting an authoritative answer. Get free facts and color brochure that tell about home business opportunities. No cost. No obligation. No salesman will visit.

MAIL COUPON TODAY!

ICS SCHOOL OF TV/VCR REPAIR, Dept. DE026
SINCE 1991 Scranton, Pennsylvania 18515

Please send me free facts on how I can learn TV/VCR Repair at home in my spare time.

Name _____ Age _____
Address _____
City/State/Zip _____
Phone () _____

MARCH 1988

DRAWING BOARD



ROBERT GROSSBLATT,
CIRCUITS EDITOR

Z80 demo program

LAST MONTH, WE SHOWED YOU A DEMONSTRATION program for our simple Z80 circuit. This month, we'll finish up the demonstration program, and then see if we can put our Z80 circuit to work.

Odds and ends

There are only two other things to talk about: the way instructions are printed and the way the program ends.

You probably noticed that, in the Op Code column in Table 1, the addresses in lines 6, 9, and 13, and the data in line 11 appear to be written backwards. To avoid getting into a lot of messy details, you'll just have to accept the fact that that's the way it's done. The reason isn't really all that important—certainly it's not as important as remembering that it is done. Your reference book may give you the answer, but unlike programming tricks, if the answer isn't there, the book is not necessarily bad. Not all microprocessors use that low-high format, either; so be careful.

About ending the program: Since all it does is to count from fifteen down to zero, we could either have it go on forever or stop after a number of runs. Of course, we chose the latter, and the HALT instruction in line 10 ends the program. After that HALT executes, the only way to make the Z80 do anything useful is to reset it.

So get an EPROM burned and plug it in. With some LED's connected to the latch you should see the count go from F down to 0 ten times. You'll get tired of watching it after a while, but it'll be thrilling the first couple of times—and at

TABLE 1—EXAMPLE PROGRAM

Line	Address	Op Code	Source Code	Comments
1	0000	AF	X0R A	Zero the Accumulator
2	0001	26 0F	LD H,0F	Set the display number
3	0003	2E A0	LD L,A0	Set the loop counter
4	0005	7C	LD A,H	Load the Accumulator
5	0006	D3 FF	OUT (FF),A	Send it to the latch
6	0008	C3 11 00	JP 0011	Go to delay subroutine
7	000B	25	DEC H	Decrement port count
8	000C	2D	DEC L	Decrement loop counter
9	000D	C2 05 00	JP NZ 0005	Do again if not zero
10	0010	76	HALT	End of the program
11	0011	11 83 8B	LD DE,8B83	Preset the delay loop
12	0014	1B	DEC DE	Decrement the counter
13	0015	C2 14 00	JP NZ 0014	Jump back if not zero
14	0018	C3 0B 00	JP 000B	Return if finished

least you'll know your circuit works.

Now that we have a working circuit, what else can we do with it? By adding a couple of things, we can make that circuit one of the most useful we've ever put together—seriously! The first addition is a keyboard, and the second is RAM. I know it sounds as if we're talking about building a complete computer, but that's not the case at all.

A keyboard could be located in the regular memory address space; doing that would make getting data as simple as reading an address. A better way to do it would be to set the keyboard up at a port address as we did with our output latch. Of course, you would access the keyboard with an IN instruction as opposed to the OUT instruction we use in the demo.

Any serious use of that circuit will require getting data in and storing it somewhere. Using the registers for storage is fine for a

demo, but for any serious use, we need some RAM.

The first thing we need to decide when adding RAM to the circuit is where it will be located. Since the Z80 starts program execution at power-up (or reset) from address 0000, it's a good idea to reserve low memory for ROM and high memory for RAM. A 2K EPROM might be addressed from 0000 to 07FF, and a 2K RAM might be addressed from F800 to FFFF. In order to access that additional memory, as well as the keyboard, you'd have to do more decoding of the RD, WR, MREQ, and IORQ lines, but that's not the real problem. As you might have guessed, the real problem is, once again, software.

But let's forget about that for a moment; let's imagine some of the spiffy things you could do with the sort of circuit we've just described:

- Look up values in a table.
- Control peripheral devices.
- Test routines for the EPROM.
- Build an intelligent keyboard.

So to get your creative juices flowing, we'll start another contest. The rules are simple. Attach a keyboard (with any number of keys) to our circuit, add some RAM, and write a program that makes the circuit do something useful—anything you want. Send me your designs, and I'll publish the best one that really works. I'll give you guest space in the column, and you'll get a free one-year subscription to **Radio-Electronics**, too. So get to work.

Memory wars

Before we begin our next adventure in circuitland, there are a few things I'd like to talk about. Although the news will be outdated by the time you read this, you should know that the so-called computer revolution has claimed its first major victim. On October 17, 1985, Mostek was closed down by its parent company, United Technologies. The reason that happened is complicated, but, in essence, Mostek was a casualty of the computer-memory war.

The mainstay of the Mostek product line was memory, and, as we all know, the Japanese have taken most of that market. By using more efficient manufacturing techniques (which consequently cut prices), Japanese semiconductor companies have captured close to 70% of the 64K market, and an astonishing 90% of the 256K market. And let's not forget that the major users of memory are all in the computer industry. When you put those two facts together, it's surprising that Mostek didn't go under even earlier.

The reason I mentioned that is as a lead-in to the subject of computers in general. The computer revolution has been with us for the last five or six years, and if the computer revolution were comparable to anything in recent memory, it would have to be the real-estate boom in Florida in the early 1970's. Computer manufacturers, peripheral manufacturers, magazine publishers, book publishers—and just about anything else you can think of—have all proliferated the past couple of years.

But now we're beginning to see the bubble burst.

If you're a regular reader of the column you've probably noticed that I don't spend much time talking about computers. They're wonderful tools; I use one every day—but I also use my multimeter every day. The point is that a computer can do all sorts of great things for you, and you can learn a lot by taking one apart. But there's a lot more to electronics than CPU's, disk drives, and software.

Computers can be a tremendous help in designing circuits, but not all programs are available for all machines. I'd like to tell you about useful software packages that make life at the workbench a bit easier. In order to do that, however, I have to know which computers you people out there are using. Take a few minutes to drop me a postcard and tell me what kind of computer you use. Don't forget to include a list of the peripherals you have. I'll put all that stuff together and keep my eyes open for packages that you should know about. **R-E**

ELECTRONIC COMPONENTS



Manufacturers of Quality Electronic Components

- BATTERY HOLDERS & CLIPS • COILS
- CAPACITORS • CONNECTORS • FUSES
- JACKS • KNOBS • LAMPS • PLUGS
- MICROPHONES • POTENTIOMETERS
- RELAYS • RESISTORS • SWITCHES
- TRANSFORMERS • SPEAKERS • LEDS
- SEMICONDUCTORS • RF COILS

OVER 15,000 DIFFERENT ITEMS IN STOCK!

MOUSER ELECTRONICS
11433 WOODSIDE AVE. SANTEE, CA 92071
PHONE (619) 449-2222 TWX 910-331-1175

CIRCLE 117 ON FREE INFORMATION CARD

Learn the IBM PC's secrets with the MICROPROFESSOR I/88



Students, engineers, or technicians—Now you can learn micro-processing and understand the technology which made the IBM PC famous.

The MPF-I/88 features:

- extensive documentation
- 16-bit central processor
- full-size keyboard
- special options

Three tutorial guides cover all capabilities. The ideal training tool! If the IBM PC or micro-processing are in your future, you owe yourself an MPF-I/88. Invest now!

Only **\$349.95**

Plus—

- Check this box for a 10% discount when you purchase within twelve days.



Dept. RE 0286
5326 9th Ave. NE
Seattle, WA 98105-3617

For immediate action call TOLL FREE:
1-800-426-1044

Full money back guarantee.



CIRCLE 251 ON FREE INFORMATION CARD

Get A Complete Course In

ELECTRONIC ENGINEERING

8 volumes, over 2000 pages, including all necessary math and physics. 29 examinations to help you gauge your personal progress. A truly great learning experience.

Prepare now to take advantage of the growing demand for people able to work at the engineering level.

Ask for our brochure giving complete details of content. Use your free information card number, or write us directly. **\$89.95**, Postage Included. Satisfaction guaranteed or money refunded.



Banner Technical Books, Inc.

1203 Grant Ave.
Rockford, IL 61103

CIRCLE 275 ON FREE INFORMATION CARD

DESIGNER'S NOTEBOOK

More single-gate designs

THINGS ARE HEATING UP IN THE ONE-gate contest again. I've received a big batch of new entries the past few weeks. This month, I'll pass along a couple of the better ones.

A few months back, you'll recall, we were looking for ways to get a negative voltage from a single-ended positive supply. At that time we built a charge-pump inverter from a 555 and a few discrete components. The circuit in Fig. 1 shows an even neater way to get a negative voltage from a positive supply. That design uses only a single inverter—and there's always an unused one in a circuit design. The circuit was submitted by Don, Bill, and John from the Companion Computer Company of Apex, North Carolina.

You can use just about any CMOS inverter for IC1-a, but a more powerful IC (like a 4049) will be able to supply more current. You may be able to parallel gates to increase current output, but that will change the operating frequency (which is set by R1 and C1) of the oscillator, hence the circuit's output voltage.

Diodes D1 and D2, along with capacitors C2 and C3, function as a voltage doubler. When IC1-a's output goes high, D1 is forward biased, so C2 begins to charge. At the same time, C1 charges up through R1. When C1 exceeds the inverter's turn on voltage, the output of IC1-a goes low. Since D2 is reverse biased with respect to C2, C2 has no way to discharge and a negative voltage appears at the output of the circuit.

The frequency of oscillation, in conjunction with the current drawn by the load, determines the

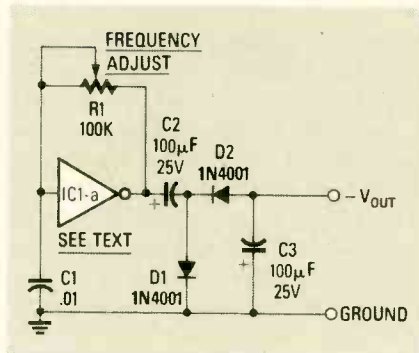

FIG. 1

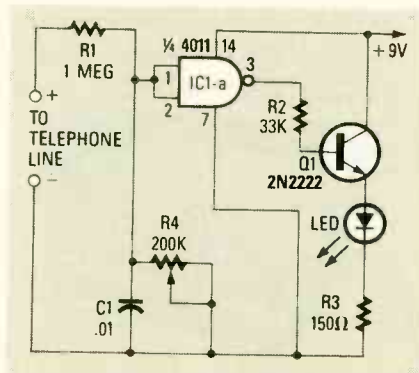

FIG. 2

output voltage of the circuit. Simulate your load with a resistor of the appropriate value, and then adjust R1 while monitoring the output with a voltmeter.

Our 555 circuit could provide about 60 mA, but a single CMOS inverter can't supply anywhere near the power of a 555. In fact, I'd be surprised if you could get more than 10 mA out of it. Even so, that circuit could save you a lot of grief when you discover that there's absolutely no way you can get an op-amp circuit working without a negative voltage.

As with any charge-pump circuit (including the 555 version), you can expect a lot of ripple. That's

not necessarily a big problem, but you'll have to keep it in mind.

Off-hook indicator

Tim Frazer of Ormund Beach, Florida sent me the circuit shown in Fig. 2. He used a single 4011 NAND gate to build a neat indicator that illuminates when the telephone is off hook. Resistors R1 and R4 function as a voltage divider that scales the phone line's output voltage to a level the gate can handle. Tim says R4 should be adjusted so that the input to the gate is 7.0 volts when the phone is on hook, and 1.1 volts when it's off hook. When the phone is off hook, the output of the gate goes high, transistor Q1 turns on, and the LED lights up.

Tim also mentioned that the DC supply should be separated from the phone line and that the circuit shouldn't be powered directly from the loop.

In the meantime, here are a few suggestions to help you get a little more out of that circuit. First, you can drive the LED directly and eliminate R2, R3, and Q1. If the LED is too dim, use a 4049 instead of the 4011. Also you should use a high-efficiency LED.

By using a diode bridge at the input to the circuit, you won't have to worry about the polarity of the phone lines. The diodes will also help isolate the circuit from the phone line, so you won't have to worry about dropping the on-hook voltage to the point where the line is accidentally seized.

Thanks again to Tim and the gang at Companion Computers. You've earned your one-year subscriptions. R-E



ROBERT GROSSBLATT
CIRCUITS EDITOR

Where's Your **ELECTRONICS** Career Headed?

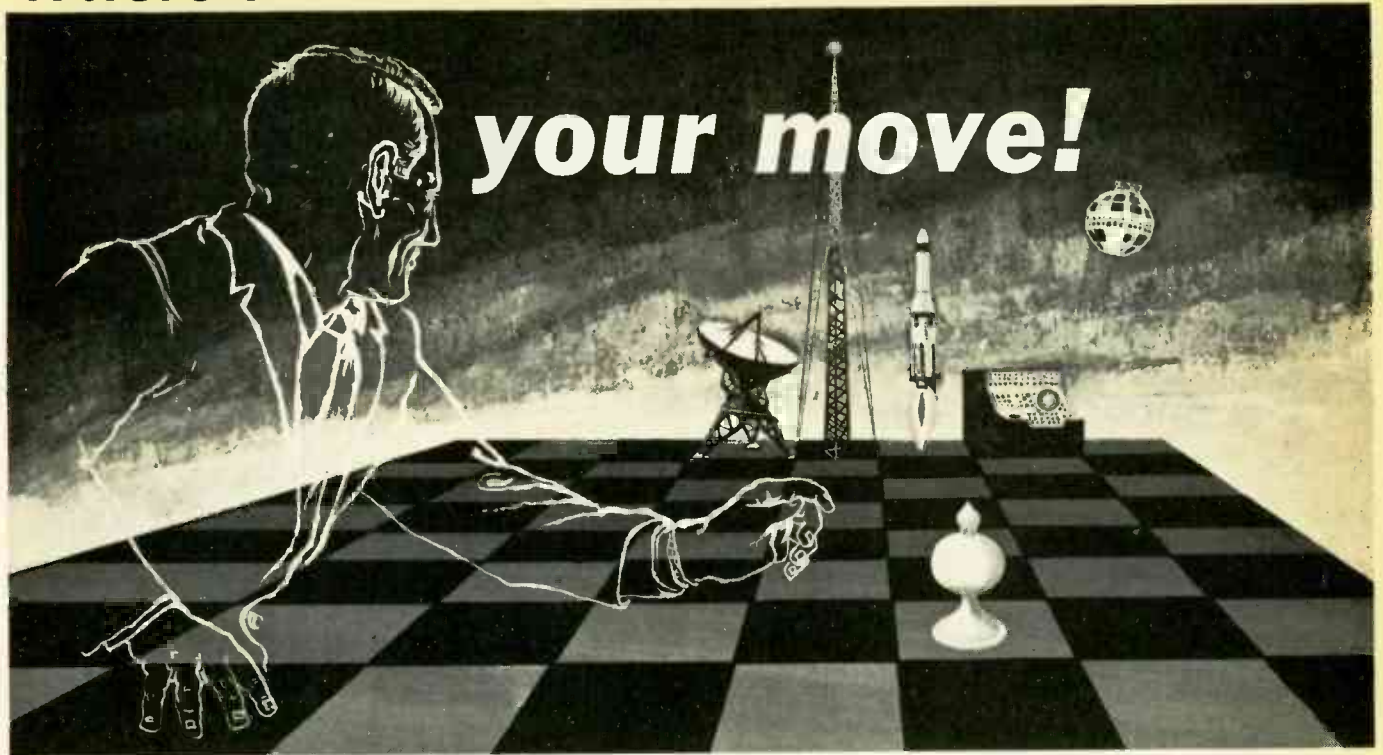

The Move You Make Today Can Shape Your Future

Yes it's your move. Whether on a chess board or in your career, you should plan each move carefully. In **electronics**, you can *move ahead* faster and further with a

B. S. DEGREE

Put professional knowledge and a **COLLEGE DEGREE** in your electronics career. Earn your degree through independent study at home, with Grantham College of Engineering. No commuting to class. Study at your own pace, while continuing your present job.

The accredited Grantham non-traditional degree program is intended for mature, fully employed workers who want to upgrade their careers . . . and who can successfully study electronics and supporting subjects through

INDEPENDENT STUDY, AT HOME

Free Details Available from:

Grantham College of Engineering
10570 Humbolt Street
Los Alamitos, California 90720

Independent Home Study Can Prepare You

Study materials, carefully written by the Grantham staff for independent study at home, are supplied by the College, and your technical questions related to those materials and the lesson tests are promptly answered by the Grantham teaching staff.

Recognition and Quality Assurance

Grantham College of Engineering is accredited by the Accrediting Commission of the National Home Study Council.

All lessons and other study materials, as well as communications between the college and students, are in the English language. However, we have students in many foreign countries; about 80% of our students live in the United States of America.

Grantham College of Engineering R-03-86
10570 Humbolt Street, Los Alamitos, CA 90720

Please mail me your free catalog which explains your B.S. Degree independent-study program.

Name _____ Age _____

Address _____

City _____ State _____ Zip _____

COMMUNICATIONS CORNER



HERB FRIEDMAN
COMMUNICATIONS EDITOR

Cross-country networking

THE WAY IT'S TOLD IN THE POPULAR press—newspapers and magazines—we are rapidly on our way to becoming a “networked” nation. That means that we will be doing much, if not all, of our daily information gathering and disseminating via computer networks.

For example, a child writing a composition for school will no longer have to spend time doing research in the library; he'll simply dial up the library's electronic database from home, using a computer and a modem. Similarly, we'll no longer need skilled electronics technicians (or skilled technicians of any sort); they'll all be replaced by minimum-wage workers who can get all the information they need on-site by using a lap computer to access the office mainframe. Even your accountant will never have to drop by: He'll simply use the telephone and a modem to tap your computer for your business records.

Networking snags

Boy, does networking sound great! But that's just the problem: It *sounds* great. In actual fact, except for a few special-purpose applications (like getting trading data on stocks and bonds), general-purpose networking has been simply underwhelming.

The problem with networking is that it is often the most *inefficient* means of communication. At its best, networking is often slow, cumbersome, and inconvenient. Consider for a moment the skilled technician in the field: The knowledge in his head is accessible to him much quicker, and much

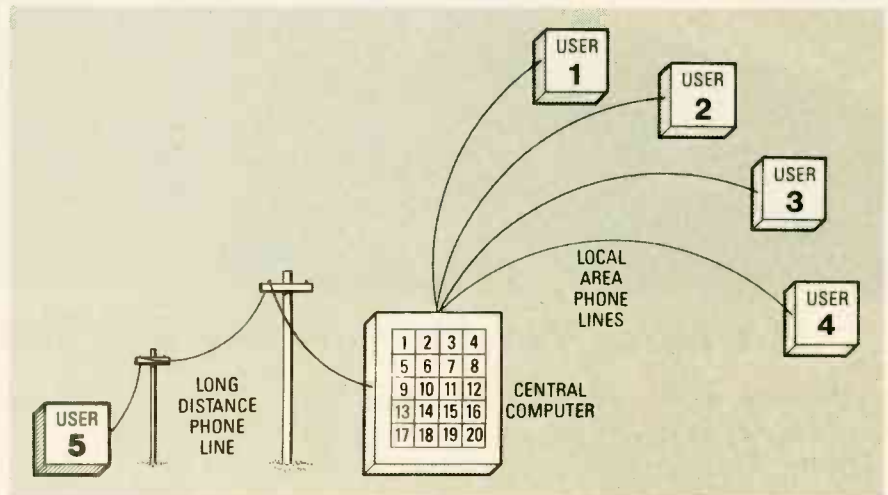

FIG. 1

more conveniently, than anything that can be sent to him by computer. If he does need reference material, he can often get it from a service manual much faster than from a computer database. That's because he can mark pertinent sections with small scraps of paper, and then flip through the book to find what he needs. With a computer, you can never keep track of where you are.

Even in the area of general-reference information sources, users have not rushed to embrace networking. Subscription rates to most services have been sharply reduced to attract subscribers, yet one of the most prestigious newspapers closed its on-line reference service for lack of use.

Even The Source and CompuServe, whose rates are reasonable, and who have experimented with many different kinds of databases, have a combined membership of only about 250,000 users, in spite of the fact that there are an estimated 10-million per-

sonal computers in homes, offices, and schools.

Or how about teletext, or videotext, or any other kind of “-text” service? Most have failed, or they survive only as an “add-on” to some other service like cable TV.

The reason for the lackluster interest in most networking is that it usually isn't a better way to communicate: It neither enhances the way we presently communicate, nor offers a new and more efficient means of exchanging information. Networking appears to be most successful when it is specifically designed, not as a substitute for the printed page, but as a totally new way to communicate, and when it provides general access to anyone, at any place, and at any time.

Enter MCI mail

The best example of that kind of thinking is MCI's Electronic Mail. MCI provides many different services, but from the communications point of view the most

important feature is the electronic mailbox. Basically, electronic mail works as shown in Fig 1. MCI's central computer can be accessed by any personal computer—local or long distance—through the switched telephone network (the dial-up system). But instead of being routed to another party for voice communications, the user is connected to the computer's storage system, in which he may store a document—a note, a letter, or any text file—for automatic transmission at some later time.

The document might then be forwarded to a computer in another city where it would be printed and then delivered by messenger or by the U. S. mail. Alternatively, the user might select conventional electronic-mailbox service wherein the document would be stored in the addressee's "mailbox." When the addressee dialed up, he would be informed that your letter was waiting.

As far as the user is concerned your document is in his "mailbox," but actually that mailbox is com-

puter memory just like other computer memory. When the addressee request his "mail," your document is moved from that memory to the user's computer terminal via the dial-up system.

At first glance, an electronic mailbox might appear as just another cute networking function with no real value, but think about it. How else could you easily step around time zones, or deliver an important document at an inconvenient time, or afford a personal FAX (facsimile) system?

Here in New York I can't start calling businesses on the coast until noon, and then my lunch hour gets tangled with their coffee breaks. We close at 5 PM; but that's the middle of the afternoon in California. And the middle of my work day is lunch hour out there. With electronic mail I simply don't have that problem. I send my message electronically, and it is "picked up" when convenient. If I need to send a message overseas I can use MCI's Telex service.

I can even use the electronic

mailbox to exchange documents with other editors in my area. If the creative juices strike someone at 3 AM, he can "drop" his "copy" in my "mailbox" in the wee hours, and I can "pick up the mail" when the sun comes up.

But perhaps the nicest feature of electronic mail is simulated FAX. A major difficulty in electronic communications has always been the reproduction of tables and charts. With electronic mail, the receiving party gets an exact copy of the original document. We can send almost anything by electronic mail, as long as it can be represented by ASCII codes.

MCI's mail services are not networking in the true sense of the word, because they aren't performed in real time—meaning there is always a delay between the sending of a document and its receipt. Nevertheless, MCI accomplishes the real purpose of networking: convenient, unattended information exchange that is no more difficult to use than existing information services. R-E

Get professional quality at home.



KeproClad is the quick, easy and inexpensive approach to home production of quality printed circuit boards. Minimum investment required.

Complete package.

KeproClad comes packaged—pre-sensitized negative acting dry film photoresist. Extremely rugged yet holds fine lines. Available in two sizes with one or two-sided copper foil. Developer included.



For your local distributor write or call:
1-800-325-3878 1-314-343-1630 (in Missouri)



Kepro Circuit Systems, Inc.

630 Axminster Drive, Fenton, MO 63026-2992

CIRCLE 263 ON FREE INFORMATION CARD

LOWEST EVER SMART BUY

from
MEGURO
(JAPAN)

20 MHz Dual Trace Oscilloscope

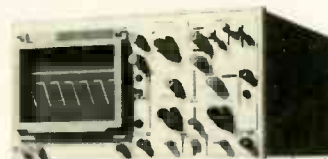

\$339⁰⁰

2-FREE Probes Included

- Built-in Component Tester
- 6" Square Internal Graticule CRT
- Sensitivity: 5mV ~ 10V/div ±3%
- Rise Time: 17ns or less
- Sweep Time: 0.2µs ~ 0.5s/div ±3%
- X-Y and Z Axis Operation
- 110/220 Volt Operation
- One Year Parts & Labor Warranty

35 MHz Scope/Delay Trigger \$499.00
Add 12.00 Per Unit for UPS & C.O.D. Charges

TO ORDER CALL COLLECT:
(213) 624-3757

Diplomat International, 453 South Spring St.,
Los Angeles, CA 90013

CIRCLE 270 ON FREE INFORMATION CARD

SEE YOUR DEALER TODAY

FROM



HERE'S A TIP THAT'S PERFECT!

AM/FM AUTO RADIO AND CB

'Firestik' II

GOLDEN SERIES

BARE-HANDS TUNABLE
"NO TOOLS NEEDED"
HIGH PERFORMANCE ANTENNAS

ALSO ANTENNAS FOR
CORDLESS TELEPHONES
MONITOR SCANNERS

Dealer & Distributor Inquiries Invited
SEND FOR FREE CATALOG

'Firestik' Antenna Company
2614 East Adams/Phoenix, AZ 85034

Name _____
Street _____
City _____
State _____ Zip _____

Serving the CB and
Communications Market Since 1962.

5-YEAR REPLACEMENT WARRANTY

CIRCLE 100 ON FREE INFORMATION CARD

STATE OF SOLID STATE



ROBERT F. SCOTT,
SEMICONDUCTOR EDITOR

Overvoltage protection

HIGH VOLTAGES STRIKE FEAR IN THE heart of circuit designers because damage by a high-voltage condition can easily cause erratic circuit operation or even catastrophic component failure. To protect circuits from overvoltage conditions, Motorola has introduced four new IC's that work with both positive and negative supplies. Those IC's sense the overvoltage condition and almost instantly "crowbar" (short circuit) the power-supply line; the dangerous voltage is thereby reduced before sensitive circuitry can be damaged. One nice feature of the new IC's is that an external capacitor may be used to program a delay between the onset of the overvoltage condition and the tripping of the crowbar. That delay provides noise immunity. The IC's also have circuitry that eliminates trip-voltage and temperature-drift errors due to SCR gate variations.

The MC34061 is a three-terminal device in a TO-92 plastic package. The basic MC34061 offers a $\pm 2\%$ trip-voltage tolerance. The corresponding figure for the MC34061/A is $\pm 1\%$, and its other key parameters have been tightened. Other features of the MC34061 include:

- 200-mA SCR gate drive
- 2.5-volt sense voltage
- 250-mV hysteresis
- 4-41-volt supply voltage

A block diagram of the MC34061 is shown, along with a typical application, in Fig. 1-a. The voltage at the comparator's inverting input (pin 3) is $(V_{CC} \times R_2)/(R_1 + R_2)$, while the voltage at the non-inverting input is $V_{CC} - 2.5$ volts. Therefore, the voltage divider (R1 and

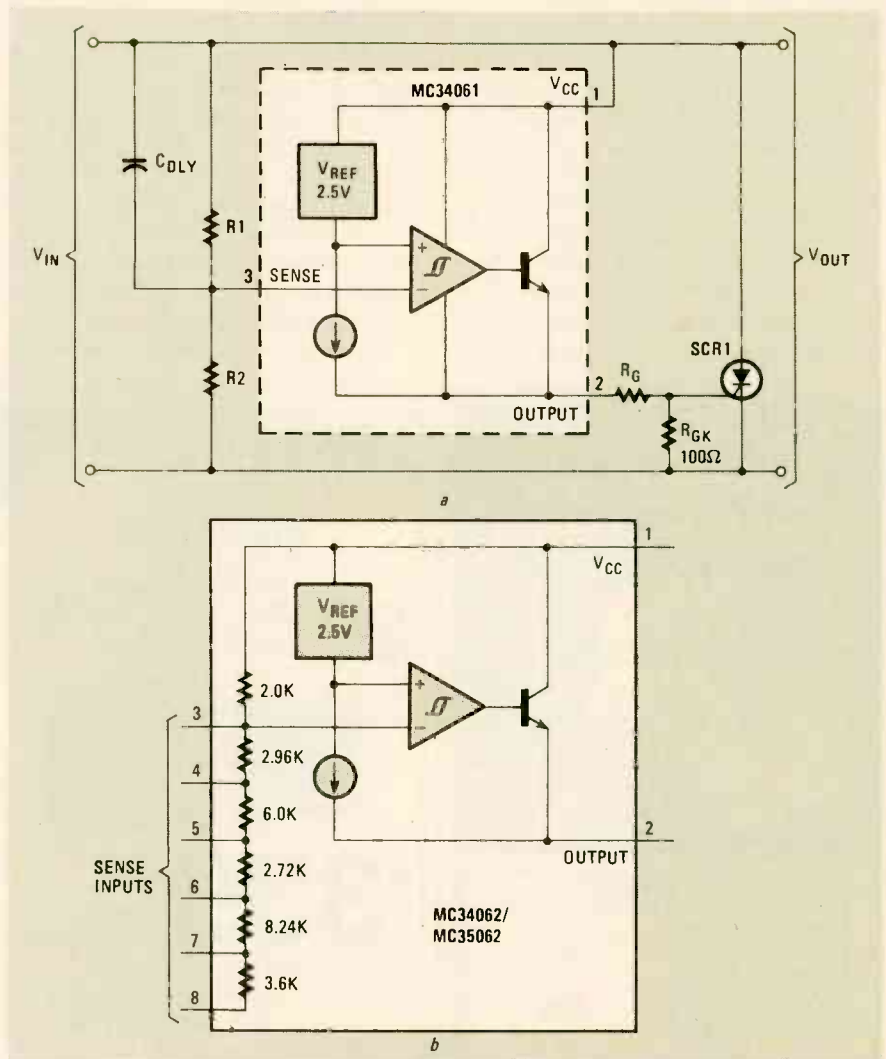

FIG. 1

R2) sets the sense-trip level, and the comparator's output is a function of V_{CC} .

The trip voltage (V_{TRIP}) equals $2.5(R_1 + R_2)/R_1$. When V_{CC} is less than V_{TRIP} , the output transistor is *off*. When V_{CC} is greater, the output transistor is *on*.

In the *off* state, a small current (the sum of the reference- and comparator-supply currents) is available at pin 2. Resistor R_{GK} may be used to shunt that current away from the driven circuit. A value of 100 ohms reduces the off-state drive to about 60 mV.

In the *on* state, the device becomes a current source capable of saturating to within 2.0 volts of V_{CC} . So, if the device must drive a high-impedance load, you'll have to clamp the output to at least 3.0 volts below V_{CC} .

Resistor R_G should be connected in series with the SCR's gate when you use a power supply greater than eleven volts. That gate resistor limits the power dissipated in the IC to about two watts. It also protects the IC if the SCR fails. The data sheets for the MC34061 supply detailed information, including nomographs, on selecting an appropriate SCR and gate resistor.

The delay provided by capacitor C_{DLY} is a function of $R1$, $R2$, C_{DLY} , as well as the nominal supply voltage and the value of the overvoltage. The magnitude of the overvoltage condition determines the rate at which C_{DLY} charges up to the reference voltage (2.5 volts). So, for given values of $R1$, $R2$, and C_{DLY} , the delay decreases as overvoltage increases. The time (in mil-

liseconds) may be found from this equation:

$$T_{DLY} = \frac{R1 \times R2 \times C_{DLY}}{R1 + R2} \times \ln \left(\frac{V_{CC} - V_{CC} (NOM)}{V_{CC} - V_{TRIP}} \right)$$

Motorola provides a nomograph that simplifies determining the time delay for various values of C_{DLY} at supply voltages ranging from 6.3 to 40 volts. In a typical 5-volt supply, $R1=1.8K$, $R2=2.7K$, $V_{CC}=5.0$ volts, and $V_{TRIP}=6.25$ volts.

The MC34062 and MC35062 are similar devices with built-in trip-point sensing. They come in eight-pin dual-in-line packages (DIP's). The MC35062U comes in a ceramic DIP and operates over the military temperature range of -55 to $+125^\circ C$. The MC34062P1 (ceramic) and MC34062U (plastic) operate over the commercial temperature range of 0 to $+70^\circ C$.

The MC34062 and MC35062 are very similar to the MC34061. They differ from it in that they include a

built-in voltage divider, as shown in Fig. 1-b, that allows the user to program a trip voltage ranging from 3.5- to 40-volts DC. By connecting the input voltage to a single pin, an MC34062/MC35062 can trip at 5, 10, 12, 15, 24, or 28 volts. By inter-connecting pins, grounding them, or both, the user can select 120 other trip voltages ranging from 3.483 to 39.064 volts.

For more information contact your local Motorola representative, or write to **Motorola Semiconductor Products, Inc.**, P. O. Box 20912, Phoenix, AZ 85036.

DAC manual

The *CMOS DAC Application Guide* is a comprehensive 63-page guide to CMOS digital-to-analog converters (DAC's). It covers the theory, operation, and applications of DAC's. Also discussed is basic DAC circuit design, and the meaning of specifications like glitches, output-leakage current, and power-supply rejection.—**Analog Devices**, P. O. Box 289, Norwood, MA 02062. R-E

TECHNICIANS,
Get serious about
your profession;



Now you can order the "Study Guide for the Associate—Level CET Test" from the International Society of Certified Electronics Technicians. It includes material covering the most often missed questions on the Associate CET Exam. 8½" x 11", paperback, 60 pages.

GET CERTIFIED!

Send to IS CET, 2708 West Berry Street, Fort Worth, TX 76109 for information.

Name _____

Address _____

City _____

State _____ Zip _____

_____ Copies at \$5 (plus \$1 postage)

_____ Send material about IS CET and becoming certified.



TUBES
and IC's
FAST DELIVERY

LOWEST PRICES
call Toll Free (800) 221-5802

In-depth Inventory - Industrial & Receiving Tubes
Here are 2 dozen examples

3-400Z	\$85.00	8122	\$130.00
3-500Z	85.00	MRF450	12.95
572B	61.50	MRF454	18.95
811A	12.00	MRF455	14.95
6146B	8.75	MRF492	19.95
M2057	15.00	6LF6	8.26
8950	12.75	6JS6C	7.46
807	5.75	6KD6	8.26
6550A	8.75	6MJ6	8.38
4CX250B	60.00	8417	8.38
6DJ8	2.75	7360	13.95
6883B	8.25	6CA7	5.55

Major Manufacturers Factory Boxed and Full line of
Sylvania ECG Replacement Semiconductors



Minimum order \$25.00

Allow \$3 UPS charge

TRANSLERONIC INC.



Box R, 1365 39th Street, Brooklyn, NY 11218

Tel. 718-633-2800/Watts Line 800-221-5802

FAX # (718) 633-4375

CIRCLE 284 ON FREE INFORMATION CARD

Be an FCC
LICENSED
ELECTRONIC TECHNICIAN!



Earn up to
\$30 an hour
and more!

Learn at home in spare time.
No previous experience needed.

No costly school. No commuting to class. The Original Home-Study course prepares you for the "FCC Commercial Radio-telephone License". This valuable license is your "ticket" to thousands of exciting jobs in Communications, Radio-TV, Microwave, Computers, Radar, Avionics and more! You don't need a college degree to qualify, but you do need an FCC License. **No Need to Quit Your Job or Go To School** This proven course is easy, fast and low cost! **GUARANTEED PASS** - You get your FCC License or money refunded. Send for **FREE** facts now. **MAIL COUPON TODAY!**

COMMAND PRODUCTIONS

FCC LICENSE TRAINING, Dept. 90
P.O. Box 2223, San Francisco, CA 94126

Please rush **FREE** details immediately!

NAME _____
ADDRESS _____
CITY _____ STATE _____ ZIP _____

MARKET CENTER

FOR SALE

TI-99/4A software/hardware bargains. Hard-to-find items. Huge selection. Fast service. Free catalog. **DYNA**, Box 690, Hicksville, NY 11801.

TUBES: "oldies" latest. Supplies, components, schematics. Send S.A.S.E. for catalog. **STEIN-**

METZ, 7519 Maplewood Ave., R.E., Hammond, Indiana 46324.

CABLE-TV FILTERS for elimination of undesirable signals. (50 dB notch) Channels available: 2 through 8; 14(A) through 22(I). Send \$20 each. **Money back guarantee.** Quantity discounts. **CATV**, Box 17621, Plantation, FL 33318.

CLASSIFIED AD ORDER FORM

To run your own classified ad, put one word on each of the lines below and send this form along with your check to:

Radio-Electronics Classified Ads, 500-B Bi-County Boulevard, Farmingdale, NY 11735

PLEASE INDICATE in which category of classified advertising you wish your ad to appear. For special headings, there is a surcharge of \$23.00.

() Plans/Kits () Business Opportunities () For Sale
() Education/Instruction () Wanted () Satellite Television
()

Special Category: \$23.00

PLEASE PRINT EACH WORD SEPARATELY, IN BLOCK LETTERS.

(No refunds or credits for typesetting errors can be made unless you clearly print or type your copy.) Rates indicated are for standard style classified ads only. See below for additional charges for special ads. **Minimum: 15 words.**

1	2	3	4	5
6	7	8	9	10
11	12	13	14	15 (\$42.75)
16 (\$45.60)	17 (\$48.45)	18 (\$51.30)	19 (\$54.15)	20 (\$57.00)
21 (\$59.85)	22 (\$62.70)	23 (\$65.55)	24 (\$68.40)	25 (\$71.25)
26 (\$74.10)	27 (\$76.95)	28 (\$79.80)	29 (\$82.65)	30 (\$85.50)
31 (\$88.35)	32 (\$91.10)	33 (\$94.05)	34 (\$96.90)	35 (\$99.75)

We accept MasterCard and Visa for payment of orders. If you wish to use your credit card to pay for your ad fill in the following additional information (Sorry, no telephone orders can be accepted.):

Card Number

Expiration Date

Please Print Name

Signature

IF YOU USE A BOX NUMBER YOU MUST INCLUDE YOUR PERMANENT ADDRESS AND PHONE NUMBER FOR OUR FILES. ADS SUBMITTED WITHOUT THIS INFORMATION WILL NOT BE ACCEPTED.

CLASSIFIED COMMERCIAL RATE: (for firms or individuals offering commercial products or services) \$2.85 per word prepaid (no charge for zip code). **MINIMUM 15 WORDS.** 5% discount for same ad in 6 issues; 10% discount for same ad in 12 issues within one year; if prepaid. **NON-COMMERCIAL RATE:** (for individuals who want to buy or sell a personal item) \$2.30 per word, prepaid....no minimum. **ONLY FIRST WORD AND NAME** set in bold caps at no extra charge. Additional bold face (not available as all caps) 50¢ per word additional (20% premium). Entire ad in boldface, add 20% premium to total price. **TINT SCREEN BEHIND ENTIRE AD PLUS ALL BOLD FACE AD:** add 25% premium to total price. **TINT SCREEN BEHIND ENTIRE AD EXPANDED TYPE AD:** add 25% premium to total price. **TINT SCREEN BEHIND ENTIRE EXPANDED TYPE AD PLUS ALL BOLD FACE AD:** add 45% premium to total price. **DISPLAY ADS:** 1" x 2 1/4" — \$310.00; 2" x 2 1/4" — \$620.00; 3" x 2 1/4" — \$930.00. **General Information:** Frequency rates and prepayment discounts are available. **ALL COPY SUBJECT TO PUBLISHERS APPROVAL. ADVERTISEMENTS USING P.O. BOX ADDRESS WILL NOT BE ACCEPTED UNTIL ADVERTISER SUPPLIES PUBLISHER WITH PERMANENT ADDRESS AND PHONE NUMBER.** Copy to be in our hands on the 12th of the third month preceding the date of the issue. (i.e., August issue copy must be received by May 12th). When normal closing date falls on Saturday, Sunday or Holiday, issue closes on preceding working day.

CABLE-TV converters and descramblers. Low prices, quality merchandise, we ship C.O.D. Send \$2.00 for catalog. **CABLETRONICS UNLIMITED**, P.O. Box 266, South Weymouth, MA 02190.

ZENITH SSAVI Manual. Original manual used by technicians. Theory of scrambling, schematics, parts list, repair for UHF and cable. For speedy delivery send \$15.00, cash or money order. **BAY STATE ELECTRONICS**, P.O. Box 263, Accord, MA 02018.

WHOLESALE audio, video, telephone accessories, antennas, cartridges. Free catalog. (718) 897-0509 **D & WR**, 68-12 110 St., Flushing, NY 11375.

CABLE and subscription TV secret manual. Build your own descramblers, converters. Instructions, schematics for sinewave, inband/outband gated sync, SSAVI—(HBO, Showtime, Cinemax UHF, etc.) Send \$8.95 to **CABLETRONICS**, Box 30502R, Bethesda, MD 20814.

LINEAR parts, tubes, transistors—MRF454 \$16, MRF455 \$12, MRF477 \$11, MRF492 \$18. Catalog. **RFPC**, Box 700, San Marcos, CA 92069. (619) 744-0728.

TEST Equipment, reconditioned. For sale. \$1.25 for catalog. **WALTER'S**, 2697 Nickel, San Pablo, CA 94806. (415) 724-0587.

ELECTRONICS catalog. Over 4,500 items. Parts & components. Everything needed by the hobbyist or technician. \$2.00 postage & handling. (States only), refundable with first \$15.00 order. **T & M ELECTRONICS**, Dept. R, 472 East Main Street, Patchogue, NY 11772. (516) 289-2520.

SCHEMATICS: Radio receivers 20's/60's. Send brandname, Model Number, SASE. **EARL SCARAMELLA**, Box 1, Woonsocket, RI 02895-0001.

TV Tunable notch filters, Free brochure. **D.K. VIDEO**, Box 63/6025, Margate, FL 33063. (305) 752-9202.

OLDTIME radio programs on high quality tapes. Comedy! Adventure! Music! Free catalogue. **CARL F. FROELICH**, Heritage Farm, New Freedom, PA 17349.

FREE Importer accessories catalog, video, audio, others. With business card write **17 BANNER COURT**, East Brunswick, NJ 08816.

RESTRICTED Technical Information: Electronic surveillance, schematics, locksmithing, covert sciences, hacking, etc. **Huge selection. Free brochure:** **MENTOR-Z**, 135-53 No. Blvd., Flushing, NY 11354.

LASERS and nightvision surplus components. Free catalog. **M. J. NEAL COMPANY**, 6672 Mallard Ct. Orient, OH 43146.

RESISTORS: 1/4W, 1/2W, 5%, C.F. \$0.03. 1% Metal-films, Custom wirewounds, capacitors and other components. **JR INDUSTRIES**, 5834-H Swancreek, Toledo, Ohio 43614.

ASSORTMENT #103—consisting of **TOKO Coils 144LY-120K, 520 HN-3000023, BKAN-K5552AXX (2); PCB; transistors, 2N3904 (2), BFQ85 (Sub); IC's 7812, 74123, MC1330A1P; diodes IN914, IN5231B.** Only \$25.00. Coils (only) \$8.00/set, **AC Adapter \$6.00. Free shipping. MC/Visa/COD. Toll free 1-800-821-5226 Ext. 426 (orders).** **JIM RHODES, INC.**, 1025 Ransome Lane, Kingsport, TN 37660.



Quality Microwave TV Antennas

Multi-Channel 1.9 to 2.7 GHz
40dB Gain True Parabolic 20 Inch Dish
Complete System \$84.95 (Shipping Incl.)
Dealerships, Qty. Pricing, Replacement Parts

Phillips-Tech Electronics

P.O. Box 34772 • Phoenix, AZ 85067

(802) 947-7700 (\$3.00 Credit all phone orders!)

LIFETIME WARRANTY MasterCard • Visa • C.O.D.

DESCRAMBLERS for downconverters. High gain. Send \$2.00. **RB ELECTRONICS**, P. O. Box 643, Kalamazoo, MI 49005.

TOKO IF transformers and coils used in video circuits. Transformer BKAN K5552AXX, \$1.80, E520-HN-300000023, \$1.00, 144LY-120K, \$1.00. Spec sheets with order. Add \$1.00 PH. **CP ELECTRONICS** P.O. Box 9056, Midland, TX 79708.

ELECTRO-MATH

NOW SOLVE THOSE ELECTRONIC AC AND DC MATH PROBLEMS ON YOUR COMMODORE 64



SOLVE FOR: Inductive reactance, capacitive reactance, total impedance, resonant frequencies, bandwidth, vector solutions R, P and P → R, decibel problems, Ohms law time constants, charge on capacitors, sine wave conversions, H.T and L pads, transformer relationships and much more.

\$19.95 design those circuits today with Electro - Math **\$19.95**
send check or money order today
Electro-Math • P.O. Box 5906, Sherman Oaks, Ca. 91413

CABLE-TV converters—All major brands. Wireless remotes with volume, wired remotes. Cable and video accessories. Cablemaster distributor. Lowest prices. Ship C.O.D.. Catalogs \$3.00. **SONE ASSOCIATES**, 5 Broadway, Suite 201, Troy, NY 12180. (518) 274-0608.

TUBES \$2.49, IC's 33 cents, 1% resistors 2 cents, SASE brings lists. **ADNF**, 6690 7 Mile So., Lyon, MI 48178.

TELECOM software for Commodore 4000/8000. **ARIEL SOFTWARE, LTD.**, 210 N. Bassett, Madison, WI 53703. (608) 258-7065.

MAKE your video system 100% cable ready with the **Quest Video Interface**. CH3 Input, audio and video outputs. \$129.95 Credit Card and COD orders accepted. **QUEST INTERFACES**, 22931 Edmonds Way, Edmonds, WA 98020. (206) 775-2110.

MOBILE telephone using your 2-way radio, plans \$9.95, with PC boards \$19.95. Parts available. **CURRENT DEVELOPMENT CORP.**, Box 384, Westmoreland, NY 13490.

LIGHT chaser, color organ controller, rope lights, triggerable neon power supply. **DESIGN SPECIALTY**, Box 1995, Huntington Beach, CA 92647.

CORDLESS phone interference? We've got the answer. Have a radar speeding ticket? We can help. Home phone extension in your car? You can have it. 50-page color catalog airmailed \$3.00. **DBE**, P. O. Drawer G, Waikiki, HI 96830.

INDIVIDUAL Photofact-folders #1 to #1400. \$3.00 postpaid. **LOEB**, 414 Chestnut Lane, East Meadow, NY, 11554.

DRAMS 41256 150ns for your PC memory expansion \$2.90. **COMPUSOURCE**, 34 Main Street, MA 02148.

RADAR detectors, CB's, scanners. Up to 50% off! Free price list 1-800-237-2897 **COMPUTRONIX** 1-312-729-2897. VISA, M/C, Amex, Checks.

CATALOG: Electronics components at budget prices for students, hobbyists and industry. Send \$2.00 P&H (refundable). **BUDGET ELECTRONICS**, Box 1477, Moreno Valley, CA 92388.

BUGGED? Wiretapped? Find out fast. Countermeasures equipment catalog \$1. **CAPRI ELECTRONICS**, Route 1R, Canon, GA 30520.

REBUILT picture tubes, monitor tubes, CRT's 1/2 or less than new price. **VIDEO ELECTRONICS**, 510-8th Ave., San Diego, CA 92101. (619) 232-4422.

CATALOG: Many cable converters. Example: N12 Minicode \$98.00. TV and cable pulse descrambler kits \$79.00. Assembled \$120.00. Satellite systems, microwave converters. Surge and RFI protectors assembled 15 ampere \$49. Hobby kits \$1. **MINUTE KITS**, Box 531, Bronx, NY 10461.

MICROWONDERLAND. Commodore computer parts! KIM-1 computers, accessories! Thousands IC's by mail! Free 64K DRAM sets! Discounts! Catalog—\$3.00! **K. BOUFAL—CONSULTING SERVICES**, 244 Fitzwater, Philadelphia, PA 19147. (215) 925-6469.

TUBES, name brands, new, 80% off list, **KIRBY**, 298 West Carmel Drive, Carmel, IN 46032.

PHILIPS wireless remotes with volume \$125. Panasonic wireless remote \$99. DR2 and DRX remotes only \$90. **REDCOAT ELECTRONICS**, P.O. Box 28504, Jamaica, NY 11128. (718) 459-5088.

IBM-PC compatible. 384K, keyboard, drive, 135W. Unused. \$700.00. **RICHARD**, (617) 792-9507.

CABLE-TV



BONANZA!

ITEM	SINGLE UNIT PRICE	DEALER 10-UNIT PRICE
RCA 36 CHANNEL CONVERTER (CH. 3 OUTPUT ONLY)	29.95	18.00 ea.
PIONEER WIRELESS CONVERTER (OUR BEST BUY)	88.95	72.00 ea.
LCC-58 WIRELESS CONVERTER	92.95	76.00 ea.
JERROLD 450 WIRELESS CONVERTER (CH. 3 OUTPUT ONLY)	105.95	90.00 ea.
SB ADD-ON UNIT	109.95	58.00 ea.
BRAND NEW — TRIMODE UNIT FOR JERROLD'S	<i>Call for specifics</i>	
MINICODE (N-12)	109.95	58.00 ea.
MINICODE (N-12) VARISYNC	119.95	62.00 ea.
MINICODE VARISYNC W/AUTO ON-OFF	179.95	115.00 ea.
M-35 B (CH. 3 OUTPUT ONLY)	139.95	70.00 ea.
M-35 B W/AUTO ON-OFF (CALL FOR AVAILABILITY)	199.95	125.00 ea.
MLD-1200-3 (CALL IF CH. 2 OUTPUT)	109.95	58.00 ea.
INTERFERENCE FILTERS — CH. 3	24.95	14.00 ea.
JERROLD 400 OR 450 REMOTE CONTROLLER	29.95	18.00 ea.
ZENITH SSAVI CABLE READY (DEALER PRICE BASED ON 5 UNITS)	225.00	185.00 ea.
SPECIFY CHANNEL 2 or 3 OUTPUT		Other products available — Please Call

Quantity	Item	Output Channel	Price Each	TOTAL PRICE
California Penal Code #593-D forbids us from shipping any cable descrambling unit to anyone residing in the state of California.			SUBTOTAL	
Prices subject to change without notice.			Shipping Add \$3.00 per unit	
			COD & Credit Cards — Add 5%	
			TOTAL	

PLEASE PRINT

Name _____

Address _____ City _____

State _____ Zip _____ Phone Number () _____

Cashier's Check Money Order COD Visa Mastercard

Acct # _____ Exp. Date _____

Signature _____

FOR OUR RECORDS:

DECLARATION OF AUTHORIZED USE — I, the undersigned, do hereby declare under penalty of perjury that all products purchased, now and in the future, will only be used on cable TV systems with proper authorization from local officials or cable company officials in accordance with all applicable federal and state laws.

Dated: _____ Signed: _____

Pacific Cable Company, Inc.

7325 1/2 RESEDA BLVD., DEPT. #10 • RESEDA, CA 91335
(818) 716-5914 • No Collect Calls • (818) 716-5140

IMPORTANT: WHEN CALLING FOR INFORMATION
 Please have the make and model # of the equipment used in your area. *Thank You*

CB MODIFICATIONS

Increase channels, range, privacy! We specialize in frequency expanders, speech processors, FM converters, PLL & slider tricks, how-to books, plans, kits. Expert mail-in repairs & conversions. 16-page catalog \$2

CBC INTERNATIONAL, P.O. BOX 31500RE, PHOENIX, AZ 85046 (602) 996-8700

PLANS & KITS

HI-FI speaker kits, auto speaker systems and speaker components from the world's finest manufacturers. For beginners and audiophiles. Free literature. **A&S SPEAKERS**, Box 7462R, Denver, CO 80207. (303) 399-8609.

CATALOG: Hobby/broadcasting/1750 Meters/Ham/CB: Transmitters, amplifiers, antennas, scramblers, bugging devices, more! **PANAXIS**, Box 130-F3, Paradise, CA 95969.

CRYSTAL radio sets, plans, parts, kits. Catalog \$1.00. **MIDCO**, 660 North Dixie Highway, Hollywood, FL 33020.

BUILD this five digit panel meter and square wave generator including an ohms, capacitance and frequency meter. Detailed instructions \$2.50. Refundable plus 50 cents. **BAGNALL ELECTRONICS**, 179 May., Fairfield CT 06430.

FILTER designer kit, a variable gain state variable filter. May be reconfigured to build most of the circuits in Don Lancaster's book, "Active Filter Cookbook." \$24.95. Indiana residents add 5% sales tax. **KEY ELECTRONICS**, P.O. Box 1, Red Key, IN 47373.

METAL detector, very sensitive, build for under \$15.00. Plans \$2.95. **POWELL**, 1162 June Drive, Xenia, OH 45385.

CABLE-TV notch filters. Super-simple helical resonator design. Plans, \$1.00. **BRYON ECKERT**, 974 E. 700, N. Provo, UT 84601.

GAS detector kit, LED bargraph display \$39.95. For listing of other kits send **SASE. Q.D.I. INC.**, P. O. Box 205, West Union, OH 45693.

TRIPLE output power supply kit. Includes PC board, all parts and cabinet. \$74.95. VCR amplifier kit, \$24.95. (CA residents add 6.5%) Catalog \$1.00, refundable with order. **CAS ELECTRONICS**, 1559-J Amar Rd., Suite 457, West Covina, CA 91792.

PC/XT compatible three boards set, motherboard, graphic, and disk card \$225.00. Less IC version \$115.00. Brochure available. **AMT TECHNOLOGY**, 1020 Bay Area Blvd., Suite 210, Houston, TX 77058. (713) 480-9506.

NEW DIGITAL REVERB FOR ORGANS

ADJUSTABLE DELAYS • MULTIPLE INPUTS
11 BIT ACCURACY • HIGH S/N RATIO
VERSATILE • QUIET • MANY USES
Send for complete information
SONIC CREATIONS INC.
P.O. Box 758, Cortez, Colorado 81321

PROJECTION TV ... Convert your TV to project 7-foot picture ... Results comparable to \$2,500 projector. Total cost less than \$30.00. Plans and 8" lens \$19.95. Illustrated information free. **MACROCOMAGG**. Washington Crossing, PA 18977. Creditcard orders 24 hours (215) 736-3979.

CABLE-TV converters: Jerrold products include "New Jerrold TRI-Mode" SB-3, Hamlin, Okn Vn-12, M-35-B, Zenith, and more. UHF deluxe II kits. (Quantity discounts) 60 day warranty. Only our converters serviced. For fast service C.O.D. orders accepted. Send SASE. (60 cents postage) or call for info (312) 637-4408, **HIGGINS ELECTRONICS**, 5143-R W. Diversey, Chicago, IL 60639. No Illinois orders accepted.

DIGITAL KLOCK KIT plays 1-of-12 melodies each quarter hour. Displays time, date, and other features. Send \$2.50 for assembly plans and pricing to **KERBER KLOCK CO.**, 36117 Hillcrest, Eastlake, OH 44094.

TESTER: a multi purpose tester capable of testing the condition of a diode, capacitor, LED, and transistor. (PNP, NPN, power trans). Continuity. Its simple but effective ckt. Limits the max. Current to under 5MA so that even sensitive devices may be tested safely. Build for \$10/ less. send \$5 for plan including electronics components. **SESTEX CO.**, BOX 23094, San-Jose, CA 95153

SATELLITE TELEVISION

UNCYPHERS American and Canadian satellite or cable. Latest technology available. Plans and boards, kits or complete. Send \$5.00 for catalogue, refundable on order, to **PILGRIM VIDEO PRODUCTS**, Box 203 Oak Street, Pembroke, MA 02359. (617) 826-8704.

COMPLETE Satellite-TV System. Dish receiver and down converter. New condition \$1,250.00. Cashiers check please. **LARRY POWELL**, 608 Main, Terrell, TX 75160.

CONVERTER descrambler schematics, service manuals, cable and satellite. New Oak Cable descrambler \$35.00, varisync units \$45.00. No Colorado sales. Call (303) 634-6666 for special wants. **PONDEROSA COMPANY**, 2408-A East Platte, Colorado Springs, CO 80909.

SATELLITE Receiver kit—Complete with PCB, chassis, all components and parts, with downconverter completely assembled and tested. 24 channel tunable video and audio. Breakthrough proven straight forward design, requires no special tools. Only \$180.00. **TECHKIT** 1111 W. El Camino Real, Suites 109-141, Sunnyvale, CA. 94087. VISA, MasterCard. Money back guarantee.

CABLE-TV Secrets—the outlaw publication the cable companies tried to ban. HBO, Movie Channel,

MICRO MART

508 Central Ave.
Westfield, N.J. 07090
(201) 654-8008

- | | | |
|--|---------|---------|
| 15 Pin Header & Mating Socket, Vert MT/PC | | |
| .156" Centers | 5/1.00 | |
| Crystal Clock Oscillator | .50 | |
| 3.300uF 35V AXIAL .12" x .78" Nich | 2/95 | |
| Coils For Radio Elec's Feb. 84 TV Project, Toko #1S T-2, L-1 (1.2uH) & L-2 (0.1uH) Complete Set Of All 4 Coils | | 8.50 |
| MC1330—Prime (Moto) | 2/1.00 | |
| BFO-85 Transistor | 1.50 | |
| Disc Caps .001uf | 20/1.00 | |
| 74123 Prime (Natl) | 3/1.00 | |
| 470uf 35V (Radial) | 3/1.00 | |
| 470uf 16V (Axial) | 4/1.00 | |
| 2N3904 | 10/1.00 | |
| 2N3906 | 10/1.00 | |
| 1N4148 | 40/1.00 | |
| 1N5211B (5.1V Zener Diode) | 5/1.00 | |
| Voltage Regulators (Prime TO-220) | .7805 | |
| 7812, 7824, 7905, 7912-Mix or Match | 3/1.00 | |
| Mica Insulators For TO-220 Pkg | 20/1.00 | |
| Voltage Reg's (Unmarked 50% Prime) May Include Positive/Neg & Adjust | 15/1.00 | |
| 78L08 Voltage Reg (DM106, TO-92) | 20/1.00 | |
| PN2222A | 20/1.00 | |
| 2N3055 | .50 | |
| 2N5308 | 20/1.00 | |
| 15 Cent (.15) Per IC TTL | | |
| 7403 | 7442 | 74126 |
| 7404 | 7450 | 74151 |
| 7410 | 7474 | 74163 |
| 7437 | 7476 | 74365 |
| 7438 | 7495 | |
| 7440 | 74107 | |
| 15 Cent (.15) Per IC 74LSXX | | |
| 74LS02 | 74LS32 | 74LS158 |
| 74LS08 | 74LS74 | 74LS174 |
| 74LS10 | 74LS86 | 74LS257 |
| 74LS20 | 74LS153 | 74LS273 |
| 20 Cent (.20) Per IC CMOS | | |
| 4001B, 4011B, 4050B, 4051B | | |
| MC838 (DTL) | | 10/1.00 |
| Opto Isolator (H11G2-6PIN DIP) Specs | 40 | |
| 2716 Eprom | | 1.45 |
| 2732 Eprom | | 1.95 |
| 2764 Eprom | | 2.45 |
| 27128 EPROM | | 4.95 |
| 256K Dram 150ns Prime Hitachi (Ideal For Mac Upgrades & Expansion Projects) | | 4.95 |
| 8243 (I/O Expander IC) W/Specs | | 2.95 |
| UDN 618 (Display Driver IC) Specs | | .85 |
| UDN 612B | | .95 |
| UCN 4116B Osc/Freq Div Clock IC Specs 5/1 | | |
| LM324 Quad OP AMP | | 3/1.00 |
| LM339 | | .45 |
| LM380 (ULN 2801) | | .45 |
| 555 Timers (DTL) | | 4/1.00 |
| NE555 (Dual Timer-Moto) | | .50 |
| 741 Op Amp | | 4/1.00 |
| LM1310 (Unmarked Tested Prime) | | .50 |

- | | | |
|--|--------------|------------|
| LM1889 | .95 | |
| LM3900 | .45 | |
| AM/FM Radio IC (#2204 W/Specs-Hobby) | 15/1.00 | |
| IC Sockets | | |
| 8 PIN/.07 | 14 PIN/.13 | 16 PIN/.15 |
| 18 PIN/.17 | 20 PIN/.19 | 22 PIN/.21 |
| 24 PIN/.22 | 28 PIN/.24 | 40 PIN/.39 |
| 7 Segment Display (3 Common Cath) | 15 | |
| 7 Segment Display (6 Common An) | 65 | |
| Tri Slate LED's | 3/1.00 | |
| Jumbo Red LED's-Diffused Lens, Prime (TI) | | |
| All 100% Prime-15/51, 100/56, 1000/557.50 | | |
| LED Mounting Clips & Rings | 15/1.00 | |
| Texas Inst/4934A Keyboard-Incr Data For Pins Made When Each Key Depressed | 4.95 | |
| Dip Switch-12 Position | 2/1.00 | |
| Dip Switch-8 Position | 4/1.00 | |
| Keyboard Push Button Tops | 30/1.00 | |
| Audio Cable | 30 Feet/1.00 | |
| 22AWG Wire | 50 Feet/1.00 | |
| 27AWG Wire | 50 Feet/1.00 | |
| Mini Lubricant (& Lubricant) | 1.00 | |
| Molex Pins (7 Pin/Strip) 100/\$2.50/4.1K/56 | | |
| MC1458 (Dual 741) | 4/1.00 | |
| ULN2274 (Dual Audio Power AMP) | .75 | |
| Rotary Switch (5 Position, 5A 125V) | 3/1.00 | |
| Giant Alpha Numeric Display 1-1/2" X 2" | | |
| 7X5 (35 Total) Red LED Matrix/Specs-4.95 | | |
| 11 LED Bar Graph Display 2-3/4" Rect LED's (Specify Red, Grn, Amber) Specs | 2.59 | |
| Seven Amp (7 Tapped Transistor Can Be Wired For) 7.5V, 9V, 15V, 18V Reg Shpg | .895 | |
| Wall Plug Transformer-24V 525mA | 1.50 | |
| 6.3V 1.2A Transformer | 1.25 | |
| 12V Center Tap Transformer | 2.90 | |
| 82AMP 220V Bodge, Quick Disconnect (GI) | .95 | |
| 1N4007 | 20/1.00 | |
| 1N5059 (200V 1 Amp) | 15/1.00 | |
| 1N5060 (400V 1 Amp) | 10/1.00 | |
| Zener Diodes 20V 1W | 30/1.00 | |
| Zener Diodes 13V 1W Glass | 30/1.00 | |
| 256.0K Crystal | | |
| 3.579545 Color Burst Crystal (HC-18) | .50 | |
| 10 Mhz Crystal | 1.95 | |
| 60 Mhz Crystal | 1.95 | |
| TO-5 Heat Sinks (Berm) | 10/1.00 | |
| TO-18 Heat Sinks (Berm) | 10/1.00 | |
| Super Sub-Mini Ceramic Caps (All 100V) | | |
| .0015uf 100V (152) | 30/1.00 | |
| .0022uf 100V (182) | 30/1.00 | |
| .0027uf 100V (272) | 30/1.00 | |
| .0033uf 100V (332) | 30/1.00 | |
| .0039uf 100V (392) | 30/1.00 | |
| .0056uf 100V (562) | 30/1.00 | |
| .0082uf 100V (822) | 30/1.00 | |
| 4.7uf 40V Lytic (Radial) | 20/1.00 | |
| 47uf 25V Lytic (Radial) | 10/1.00 | |
| 1000uf 185V Twist Lock | 1.00 | |
| 1000uf 50V (Ideal For Power Supplies)-1.00 | | |
| 5600uf 25V (Comp Grade 3-5/8" X 1)-3/1.00 | | |
| 1uf 50V Monolithics | 10/1.00 | |
| 01uf 50V Monolithics | 20/1.00 | |

- | | |
|---|---------|
| Chip Caps-Set of 4, 2 Each 2.7 & 3.3pF-1.00 | |
| 33uf 100V Dip Mylar | 10/1.00 |
| IN4004 Diodes | 30/1.00 |
| Rect 1 Meg Linear Taper | 5/1.00 |
| Motion Detector Bds (Inc IC \$2) | 7/10.00 |
| Mot Det (IC Only-ULN2232A) 3/52-20/10.00 | |
| Project Box/Ltd For Detector | 1.95 |
| Miniature Speaker For Detector | .65 |
| Extensive Construction Article For Det. \$1 | 15/1.00 |
| TV Knobs | |
| Ammeter (0-15 A.C. Amperes) | 4.95 |
| Volt/OHM Meter MVMNT (0-1K OHM, 0-300V) | 2.95 |
| 6V Miniature Gear Motor | .50 |
| RF Chokes-1.8uH, 8.2uH, 12uH, 22uH-10/1.00 | |
| 40 Pin Flat Cable Socket Connector/Hood | .40 |
| 50 Pin Flat Cable Socket Connector/Hood | .50 |
| 14 Pin Dip Header Plug/Mate (3M) | 3/1.00 |
| Mixed Connector Ass't | 10/1.00 |
| 1.5AMP 50V Bridge (GI, TO-5 Pkg) | .50 |
| 25AMP 200V Bridge (Solder Lug Term) | 1.50 |
| Zenith TV Replacement IC Special \$1 Each | |
| 221-42, 221-43, 221-45, 221-48, 221-69, 221-79, 221-87, 221-96, 221-104, 221-105, 221-106, 221-140 | |
| 2SD0901 (Incr Output W/Damper Diode)-2.95 | |
| 2SC1172B (Toshib-Horiz Output Trans)-1.95 | |
| Winegard 4 Bay Bowtie UHF Antenna-19.50 | |
| IC Storage (Bug) Box (Holds) 30 IC's-1.75 | |
| Precision (Multi-Turn) Trim Pots (Copal), 100 OHM, 500 OHM, 1K, 2K, 5K, 10K, 20K, 50K, 100K, 200K, 500K, 1M, 55 Each-\$3.52 | |
| Pher-POT-10V Hor Mt (Single Turn) Trimmers 100 OHM, 1K, 10K, 25K, 50K, 100K, 4/1.50 | |
| High Sensitive Switch/150°C | 10/1.00 |
| Mixed Coil Ass't | 10/1.00 |
| Buzzers | 3/1.00 |
| Chip Resistor (6.8K) | 20/1.00 |
| Chip Resistor (470K) | 20/1.00 |
| Chip Cap (330pF) | 20/1.00 |
| 36 Pin RI, Angle Header Connector | .50 |
| MRF901 (Hobby Grade-60% Good) | 10/1.00 |
| IC Ass't (Hobby Grade, Some Marked)-30/\$1 | |

20 Cent (.20) 74SCXX Series Special

- Octal Interface Circuits
 - Equivalent To 74LSXX Series
 - Low Power ISO-CMOS Technology
 - Short Propagation Delay
 - Improved Noise Margins
 - High Current, Sink/Source Capability
- 74SC137-1 Of 8 Inverted Decoder, Latched
74SC138-1 Of 8 Inverted Decoder
74SC139-1 Of 4 Inverted Decoder
74SC237-1 Of 8 Non-Inverted, Latched
74SC238-1 Of 8 Non-Inverted
74SC239-1 Of 4 Non-Inverted
74SC240-Octal Buffer/Line Driver-Inv
74SC241-Octal Buffer/Line Driver-N/I
74SC242-Octal Buffer/Line Driver-N/I
74SC245-Octal Bus Transceiver-N/I
74SC373-Transoarent Latch-N/I

Terms: MICRO-MART accepts Visa, MC and telephone COD's. Minimum order \$10.00. Shipping—U.S. orders, \$2.00. Canada and other countries \$3.50 (includes ins.) Shipping rate adjusted where applicable. NJ residents add 6% sales tax.
MICRO-MART • 508 CENTRAL AVE., WESTFIELD, NJ 07090 • (201) 654-8008

- | | |
|--------------------------------------|------|
| 74SC374-D Type Flip-Flop, Non/Inv | |
| 74SC533-Transparent Latch-Inverted | |
| 74SC534-D Type Flip-Flop, Inverted | |
| 74SC540-Octal Buffer/Line Driver-Inv | |
| 74SC541-Octal Buffer/Line Driver-N/I | |
| 74SC563-Transparent Latch, Inverted | |
| 74SC564-D Type Flip-Flop, Inverted | |
| 74SC573-Transparent Latch, Non/Inv | |
| 74SC574-D Type Flip-Flop, Non/Inv | |
| Data Book For All Above * \$ | 2.50 |

Cypher IV Micro-Controller Kit \$129.50

- 4 MHz, 8-Bit Microprocessor (NAT 1NS8073)
- Control Basic Interrupter On-Chip
- Auto-Start Operation At Power-On
- Fast 16-Bit Multiply And Divide
- RS-232, Supports CRT & Serial Link
- 24 Bi-Directional I/O Lines (8255A)
- RAM Memory-2K Expandable To 16K
- Eprom Memory-Expandable To 16K
- Built In Eprom Programmer
- Parr (Centronic) Printer Interface
- Optional Real-Time Clock W/Backup

Pay TV Hardware Installation Kit Blow Out As Low As \$2.95 + \$3.50 Shipping Per Unit

- All Kits Contain 5 F Connectors, 300 to 75 OHM Balun, 300 OHM Terminal Block 2 Ft
- 75 OHM Patch Cord 2 Ft 300 OHM Twin Lead
- Nylon Cable Ties, And UHF Antenna
- Model #41124-\$2.95 Includes All Of The Above Plus 25 Feet Coaxial Cable And Mounting Hardware For Indoor Wall/Ceiling Installation
- Model #4880-\$2.95 Includes All Of The Above Plus 25 Feet Coaxial Cable And Attractive Expandable Pole/U-Bolt For Easy Indoor Installation
- Model #4845-\$3.95 Includes All Of The Above Plus 65 Feet Coaxial Cable And All Necessary U-Bolt Hardware

MODEL 705 Digital Multimeter

- | | |
|-----------------|-------------------------|
| DC Voltage | 100uV to 1000V |
| AC Voltage | 100uV to 750V |
| DC Current | 0.1uA to 10A |
| AC Current | 0.1uA to 10A |
| Hi-Z Resistance | 0.1 Ohm to 20M |
| Capacitance | 1pF to 20uF |
| Diode Test | forward voltage testing |
| Hrs Test | transistor testing |
- \$51.95

UHF-TV PREAMP

(As featured in Radio Electronics March/May articles, 1982)
This inexpensive antenna mounted pre-amp can add more than 25 dB of gain to your system. Lots of satisfied customers and repeat orders for this high quality kit, which includes all component parts, PC BD, Case, Power Supply and Balun \$34.50
Assembled Version \$57.50

RAMSEY

THE FIRST NAME IN ELECTRONIC TEST GEAR

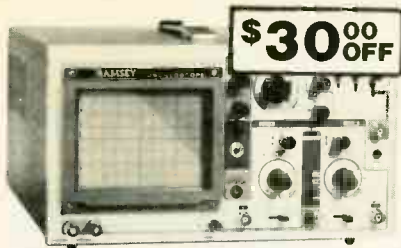

\$30⁰⁰ OFF

Save \$30 on the RAMSEY 20MHz Dual Trace Oscilloscope

Unsurpassed quality at an unbeatable price, the Ramsey oscilloscope compares to others costing hundreds more. Features include a component testing circuit for resistor, capacitor, digital circuit and diode testing • TV video sync filter • wide bandwidth & high sensitivity • internal graticule • front panel trace rotator • Z axis • high sensitivity x-y mode • regulated power supply • built-in calibrator • rock solid triggering

Was \$399.95 NOW ONLY **\$369.95** high quality hook on probes included

NEW 35 MHz DUAL TRACE OSCILLOSCOPE

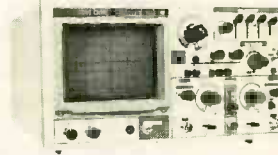

A heavy duty and accurate scope for service as well as production use. Features include • wide frequency bandwidth • optimal sensitivity • extremely bright display • delayed triggering sweep • hold off • ALT trigger • single sweep • TV sync • 5X magnification • XY or XYZ operation • HF/LF noise reduction

3500 Dual Trace Oscilloscope \$499.95 includes 2 high quality probes

ALL OSCILLOSCOPES INCLUDE 2 PROBES

NEW 15 MHz DUAL TRACE PORTABLE OSCILLOSCOPE

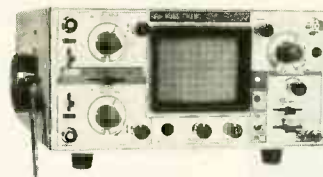

Ideal for field/bench applications, this scope can display up to 15 MHz signals. Internal battery pack allows up to 2 hours operation on a single charge. Features include • built-in battery charger • 5X horizontal magnification • high brightness CRT • front panel trace rotator • internal rechargeable battery pack

2500 Portable Oscilloscope \$449.95 includes 2 high quality probes



NEW RAMSEY 1200 VOM MULTITESTER

Check transistors, diodes and LEDs with this professional quality meter. Other features include, decibel scale • 20K volt metering system • 3 1/2" mirrored scale • polarity switch • 20 measuring ranges • safety probes • high impact plastic case

\$19.95 test leads and battery included



NEW RAMSEY D-4100 COMPACT DIGITAL MULTITESTER

Compact sized reliability and accuracy. This LCD digital multimeter easily fits in your pocket, you can take it anywhere. It features full overload protection • 3 1/2 digit LCD readout • recessed input jacks • safety probes • diode check function • 2000 hours battery life

\$22.95 test leads and battery included

MINI KITS—EASY TO ASSEMBLE, FUN TO USE BEGINNERS & PROS WILL HAVE A GREAT TIME WITH THESE KITS

FM MINI MIKE

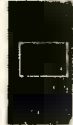

A super high performance FM wireless mike kit. Transmits a stable signal up to 300 yards with exceptional audio quality by means of its built in electret mike. Kit includes case, mike, on-off switch, antenna, battery and super instructions. This is the finest unit available.

FM-3 Kit **\$14.95**
FM-3 Wired and Tested **19.95**

Color Organ

See music come alive! 3 different lights flicker with music. One light each for, high, mid-range and lows. Each individually adjustable and drives up to 300 W. runs on 110VAC.

Complete kit, ML-1 **\$8.95**

Video Modulator Kit
Converts any TV to video monitor. Super stable, tunable over ch 4-6. Runs on 5-15V accepts std. video signal. Best unit on the market! Complete kit, VD-1 **\$9.95**



Led Blinky Kit
A great attention getter which alternately flashes 2 jumbo LEDs. Use for name badges, buttons, warning panel lights, anything! Runs on 3 to 15 volts. Complete kit, BL-1 **\$2.95**

Super Sleuth
A super sensitive amplifier which will pick up a pin drop at 15 feet! Great for monitoring baby's room or as general purpose amplifier. Full 2W rms output, runs on 6 to 15 volts, uses 8-45 ohm speaker. Complete kit, BN-9 **\$5.95**

CPO-1
Runs on 3-12 Vdc 1 wall out, 1 KHZ good for CPO, Alarm, Audio Oscillator. Complete kit **\$2.95**

FM Wireless Mike Kit



Transmits up to 300' to any FM broadcast radio, uses any type of mike. Runs on 3 to 9V. Type FM-2 has added sensitive mike preamp stage.

FM-1 Kit **\$3.95** FM-2 Kit **\$4.95**

Whisper Light Kit

An interesting kit, small mike picks up sounds and converts them to light. The louder the sound, the brighter the light. Includes mike, controls up to 300 W. runs on 110 VAC.

Complete kit, WL-1 **\$6.95**

Tone Decoder

A complete tone decoder on a single PC board. Features: 400-5000 Hz adjustable range via 20 turn pot, voltage regulation, 567 IC. Useful for touch-tone burst detection, FSK, etc. Can also be used as a stable tone encoder. Runs on 5 to 12 volts. Complete kit, TD-1 **\$5.95**



Siren Kit
Produces upward and downward wail characteristic of a police siren. 5 W peak audio output, runs on 3-15 volts, uses 3-45 ohm speaker. Complete kit, SM-3 **\$2.95**

60 Hz Time Base
Runs on 5-15 VDC. Low current (25ma) 1 min/month accuracy TB-7 Kit **\$5.50**
TB-7 Assy **\$9.95**

Universal Timer Kit

Provides the basic parts and PC board required to provide a source of precision timing and pulse generation. Uses 555 timer IC and includes a range of parts for most timing needs.

UT-5 Kit **\$5.95**

Mad Blaster Kit

Produces LOUD ear shattering and attention getting siren like sound. Can supply up to 15 watts of obnoxious audio. Runs on 6-15 VDC.

MB-1 Kit **\$4.95**

Power Supply Kit

Complete triple regulated power supply provides variable 6 to 18 volts at 200 ma and -5 at 1 Amp. Excellent load regulation, good filtering and small size. Less transformers, requires 63V (a 1 A and 24 VCT. Complete kit, PS-3LT **\$6.95**

30 Watt 2 mtr PWR AMP

Simple Class C power amp features 8 times power gain. 1 W in for 8 out, 2 W in for 15 out, 4 W in for 30 out. Max output of 35 W, incredible value, complete with all parts, less case and T-R relay.

PA-1, 30 W pwr amp kit **\$22.95**
TR-1, RF sensed T-R relay kit **6.95**

CT-70 7 DIGIT 525 MHZ COUNTER

Lab quality at a breakthrough price. Features • 3 frequency ranges each with pre amp • dual selectable gate times • gate activity indicator • 50mV @ 150 MHz typical sensitivity • wide frequency range • 1 ppm accuracy

\$119.95 wired includes AC adapter
CT-70 kit **\$99.95**
BP-4 nicad pack **8.95**

CT-50 8 DIGIT 600 MHZ COUNTER

\$169.95 wired
CT-50 kit **\$139.95**
RA-1 receiver adapter kit **14.95**

CT-90 9 DIGIT 600 MHZ COUNTER

The most versatile for less than \$300. Features 3 selectable gate times • 8 digits • gate indicator • display hold • 25mV @ 150 MHz typical sensitivity • 10 MHz timebase for WWV calibration • 1 ppm accuracy

\$149.95 wired includes AC adapter
CT-90 kit **\$129.95**
OV-1 0.1 PPM oven timebase **59.95**
BP-4 nicad pack **8.95**

CT-125 9 DIGIT 1.2 GHZ COUNTER

\$169.95 wired includes AC adapter
CT-125 kit **\$149.95**
BP-4 nicad **8.95**

DM-700 DIGITAL MULTIMETER

Professional quality at a hobbyist price. Features include 26 different ranges and 5 functions • 3 1/2 digit, 1/2 inch LED display • automatic decimal placement • automatic polarity

\$119.95 wired includes AC adapter
DM-700 kit **\$99.95**
MP-1 probe set **4.95**

PR-2 COUNTER PREAMP

The PR-2 is ideal for measuring weak signals from 10 to 1,000 MHz • flat 25 db gain • BNC connectors • great for shifting RF • ideal receiver/TV preamp

\$44.95 wired includes AC adapter
PR-2 kit **\$34.95**

PS-2 AUDIO MULTIPLIER

The PS-2 is handy for high resolution audio resolution measurements, multiplies up in frequency • great for PL tone measurements • multiplies by 10 or 100 • 0.01 Hz resolution & built-in signal preamp/conditioner

\$49.95 wired
PR-2 kit **\$39.95**

PS-10B 1.5 GHZ PRESCALER

Extends the range of your present counter to 1.5 GHz • 2 stage preamp • divide by 1000 circuitry • super sensitive (50 mV typical) • BNC connectors • 1 GHz in, 1 MHz out • drive any counter

\$79.95 wired includes AC adapter

ACCESSORIES FOR RAMSEY COUNTERS

- Telescopic whip antenna—BNC plug **\$ 8.95**
- High impedance probe, light loading **16.95**
- Low pass probe, audio use **16.95**
- Direct probe, general purpose use **13.95**
- Tilt bail, for CT-70, 90, 125 **3.95**

PHONE ORDERS CALL **716-586-3950**
TELEX 466735 RAMSEY CI

TERMS: • satisfaction guaranteed • examine for 10 days; if not pleased, return in original form for refund • add 6% for shipping and insurance to a maximum of \$10.00 • overseas add 15% for surface mail • C.O.D. add \$2.50 (C.O.D. in USA only) • orders under \$15.00 add \$1.50 • NY residents add 7% sales tax • 90 day parts warranty on all kits • 1 year parts & labor warranty on all wired units.



RAMSEY ELECTRONICS, INC.
2575 Baird Rd.
Penfield, N.Y. 14626

CIRCLE 70 ON FREE INFORMATION CARD

Showtime, descramblers, converters, etc. Suppliers list included. \$8.95. **CABLE FACTS**, Box 711-R, Pataskala, OH 43062.

CABLE-TV Source Book—a complete listing of suppliers for hard-to-find converters, descramblers, technical information, schematics and much more. Full refund if not satisfied. Send \$4.95 to **CABLE**, Box 12505-R, Columbus, OH 43212.

SATELLITE systems \$449. Name brands. Information \$1. Catalog \$2. **STARLINK, INC.**, 2603-164R Artie, Huntsville, AL 35805.

BUILD your own satellite TV receiving system and save! Instruction manuals, schematics, circuit boards, parts kits! Send stamped envelope for complete product listing: **XANDI**, Box 25647, Dept. 21Y, Tempe, AZ 85282.

THE LNA specialists! Brand name, lowest noise, lowest prices! We will not be undersold! Send for prices: **LNA**, 201 E Southern, Suite 100, Tempe, AZ 85282.



A SINGER'S DREAM!

REMOVES VOCALS FROM RECORDS!

Now You can sing with the world's best bands! The Thompson Vocal Eliminator can remove most or virtually all of a lead vocal from a standard stereo record and leave the background!

Write or call for a free brochure and demo record.

LT Sound, Dept. R-1, P.O. Box 338, Stone Mountain, GA 30086. (404) 493-1258

SATELLITE-TV systems ... lowest prices! Name Brand dishes, receivers, LNAs, etc. Factory guaranteed. Free catalog. **TITANSAT**, Box 101, Lemont, PA 16851.



WRITE FOR McGEE'S

SPEAKER & ELECTRONICS CATALOG

1001 BARGAINS IN SPEAKERS

toll free 1-800-346-2433 for ordering only.

1901 MCGEE STREET KANSAS CITY, MO. 64108

EDUCATION & INSTRUCTION

F.C.C. Commercial General Radiotelephone License. Electronics Home Study. Fast, inexpensive! "Free" details. **Command**, D-176, Box 2223, San Francisco 94126.

ELECTRONICS courses, mailed monthly basis. \$2.00 for details refundable with purchase. 1632 N. **LECLAIRE**, Chicago, IL 60639.

PASS FCC general radiotelephone examination. FCC questions with simplified answers plus FCC-Type multiple choice questions - 160 PAGES \$5.95. Also available - complete general radiotelephone easy-to-understand home study course - 450 pages \$8.95. **AMECO PUBLISHING**, 220 E. Jericho Turnpike, Mineola, NY 11501.

INVENTORS

INVENTORS! Can you profit from your idea? Call **AMERICAN INVENTORS CORPORATION** for free information. Over a decade of service. 1-800-338-5656. In Massachusetts call (413) 568-3753.

BUSINESS OPPORTUNITIES

YOUR own radio station! AM, FM, TV, Cable. Licensed/unlicensed. **BROADCASTING**, Box 130-F3, Paradise, CA 95969.

MECHANICALLY inclined individuals desiring ownership of small electronics manufacturing business—without investment. Write: **BUSINESSES**, 92-R, Brighton 11th, Brooklyn, NY 11235.

ELECTRONIC ASSEMBLY SCHOOL, well established southern California location. Growth potential. New owner. Training. \$68,000.00, terms, (714) 530-8897 owner.

BIG PROFITS

ELECTRONIC ASSEMBLY BUSINESS

Start home, spare time. Investment knowledge or experience unnecessary. **BIG DEMAND** assembling electronic devices. Sales handled by professionals. Unusual business opportunity.

FREE: Complete illustrated literature
BARTA, RE-O Box 248
Walnut Creek, Calif. 94597

ELECTRONICS Able to repair, draw, assemble, wire, maintain machines, know different languages. **P.O. BOX 962**, Murray Hill Station, NYC 10156.

PROJECTION TV Make \$\$\$'s assembling projectors ... easy ... results comparable to \$2,500 projectors ... your total cost less than \$20.00 ... plans, 8" lens & Dealers information \$17.50 ... Illustrated information free ... **MACROCOMA-GGX**, Washington Crossing, PA 18977. Credit card orders 24 hours (215) 736-2880.

WANTED

RADIO tubes: 2A3, 45's, 50's, 211, 845. Western Electric tubes, amps, drivers, horns, speakers. **DAVID**, P.O. Box 832, Monterey Park, CA 91754, Tel: (818) 576-2642.

WM. B. ALLEN LEADING THE WAY WITH LEADER

CALL TOLL FREE FOR ALL AUDIO AND VIDEO NEEDS
ASK FOR JOHN OR PHIL

800 535-9593

LOUISIANA ONLY 800 462-9520

LBO 516

100 MHZ - 3 CH.

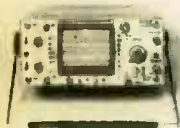

- Eight Trace Capability
- Alternate Triggering
- High Vertical Input Sensitivity
- Excellent Triggering Sensitivity

\$1435

LBO 524L

35 MHZ - 2 CH.



- 500 μ V Sensitivity
- Calibrated Delayed Time Base
- Alternate Triggering
- CH-1 Output

\$890

LBO-518 \$1985

LBO-525L \$1156

LBO-524 \$ 843

LBO-523 \$ 759

LBO-513A \$ 399

LBO-310A \$ 259

LBO-5825 \$3727

LBO 522

20 MHZ - DT



- 500 μ V Sensitivity
- Variable Hold-off
- 8 x 10 cm Display
- Alternate Triggering

\$589

LBO 514

15 MHZ - DT



- 1 mV Sensitivity
- 5" CRT
- 0.1 μ s Sweep Speed
- X-Y Mode

\$394

WM. B. ALLEN SUPPLY COMPANY ALLEN SQUARE

300 BLOCK NORTH RAMPART STREET, NEW ORLEANS, LOUISIANA 70112

TEST EQUIPMENT HOUSE OF THE SOUTH

CIRCLE 103 ON FREE INFORMATION CARD

TENMA

THE NAME YOU CAN TRUST IN ELECTRONIC TEST EQUIPMENT

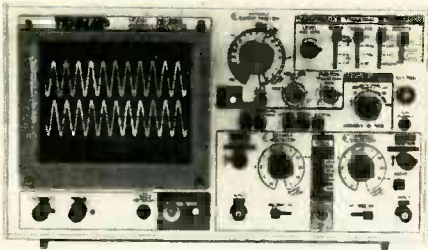

TENMA 35 MHz Dual Trace Oscilloscope

- Two high quality 10:1 probes included
- For additional specifications see MCM Catalog #11

#72-330

\$56900
(ea)



TENMA Autoranging Digital Multimeter

- 3½ digit ■ Auto polarity ■ Low battery indicator
- 10 amp AC-DC current ■ Continuity buzzer ■ 2¼" x 5¾" x 1¾"
- Carrying case included

#72-058 \$49.80 (1-4)

\$4495
(2-up)

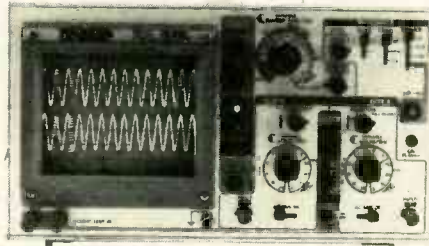

TENMA 20 MHz Dual Trace Oscilloscope

- Two high quality 10:1 probes included
- For additional specifications see MCM Catalog #11

#72-320

\$38995
(ea)



TENMA Capacitance Meter

- Measures capacitors from 0.1pF to 19.999mF
- Accuracy 0.5% ■ Checks capacitors in and out of circuit ■ Carrying case included

#72-040 \$59.80 (ea)

\$5495
(2-up)



NEW

TENMA Rotary Dial DMM

- 3½ digit LCD display ■ Rotary dial for rapid selection of functions and ranges
- 20 amp AC-DC current ■ .1ohm resolution ■ Carrying case included

#72-075 \$44.80 (ea)

\$4195
(2-up)

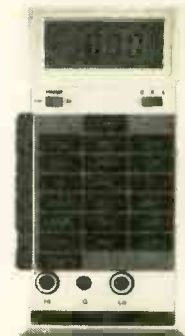

NEW

TENMA Digital LCR Meter

- Measures inductance, capacitance and resistance ■ L = 1 micro H to 200H, C = 1pF to 200 micro F, R = .01ohm to 20Mohm ■ Carrying case included.

#72-370

\$14995
(ea)



TENMA Combination Function Generator and Frequency Counter

- 6 digit display ■ Output range: .2Hz to 2MHz seven ranges ■ Counter range .1Hz to 10MHz ■ 5-15 volt TTL and CMOS output ■ Wave forms: sine, triangle, square, pulse, and ramp.

#72-380

\$21990
(ea)

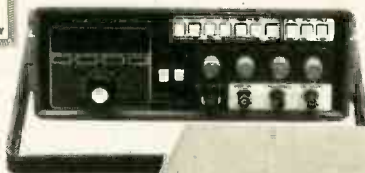

TENMA Frequency Counter

- 8 digit LED display ■ Measurement range: 1Hz - 120MHz ■ High input sensitivity of 20mV RMS

#72-375 **\$18995**
(ea)

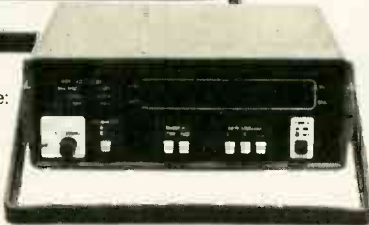

NEW

MCM ELECTRONICS
358 E. Congress Park Dr.
Centerville, Ohio 45459-4072
(513) 434-0031

SOURCE NO. RE-18

Terms:

- \$10 minimum order. \$1.00 charge for orders under \$10.
- \$20 minimum charge card order.
- Orders shipped UPS C.O.D.
- Most orders shipped within 24 hours.
- Sales office open 9:30 am to 7:00 pm Saturdays 10:00 am to 3 pm EST.
- For prepaid orders add \$2.75 for shipping and handling.
- Should shipping and handling charges exceed \$2.75, the balance due will be sent C.O.D.



Be Sure To Call For Your FREE Catalog! Over 6,000 Items!

We also have ... a full line of test equipment, computer accessories, telephone accessories, speakers, television parts, flybacks, yokes, switches, fuses, lamps, capacitors, resistors, cartridges, styli, wire, CATV equipment, the largest selection of original Japanese semiconductors in the country and more.

CALL TOLL FREE 1-800-543-4330
In Ohio 1-800-726-4315 • In Alaska and Hawaii 1-800-858-1849

CIRCLE 87 ON FREE INFORMATION CARD

Saratoga Electronics



ORDER TOLL FREE

800-621-0854
ext.245

DYNAMIC RAMS

4164 - 150NS \$1.00
41256 - 150NS \$2.45

EPROMS

2716 - 450NS \$1.95
2732A - 450NS \$2.25
2764 - 450NS \$2.50
2764 - 250NS \$2.00
27256 - 300NS \$5.95

PC/AT COMPATIBLE SYSTEM BOARD

- ★ 1 Megabyte Installed
- ★ Dual Speed Selectable at 6 or 8 MHZ
- ★ Compatible "AT" System Bios
- ★ 8-Slot Expansion Capability
- ★ Complete & Tested w/90 - Day Warranty

\$895

PC/XT COMPATIBLE SYSTEM BOARD

- ★ 64K Installed - Expandable to 640 KB
- ★ 4.77 MHZ Speed
- ★ Compatible "XT" System Bios
- ★ 8 - Slot (Full) Expansion Capability
- ★ Complete & Tested w/ 90 - Day Warranty

\$200

\$25 MINIMUM ORDER

12380 SARATOGA - SUNNYVALE ROAD
SARATOGA, CA 95070

(408) 446 - 4949



TUBES — OVER 2000 TYPES! DISCOUNT PRICES



Parts, supplies, and literature for tube type radios, including early and hard-to-find tubes.

Send \$1.00 for 24 page wholesale catalog.

ANTIQUE ELECTRONIC SUPPLY

688-B W. First St. • Tempe, AZ 85281 • (602) 894-9503

INVENTIONS, ideas, new products wanted! Industry presentation/national exposition. Call free 1-800-528-6050. Canada, 1-800-528-6060. X831.

INVENTORS! AIM wants—ideas, inventions, new products, improvements on existing products. We present ideas to manufacturers. Confidentiality guaranteed. Call Toll Free 1-800-225-5800 for information kit.

REEL-TO-REEL TAPES

AMPEX professional series open reel tape. 1800- or 2400-feet on 7-inch reels, used once. Case of 40, \$45.00 10 1/2" x 3600 feet and cassettes available. MasterCard, Visa. VALTECH ELECTRONICS, Box 6-RE, Richboro, PA 18954 (215) 322-4866.

CABLE TV

DEALERS wanted: Channel 2, 3, and 4 notch filters. Money back guarantee. Send \$15.00 for sample and quantity price list. Specify channel(s). GARY KURTZ, P.O. Box 291394, Davie, FL 33329.

PRINTED-CIRCUIT BOARDS

PRINTED-circuit boards. Quick prototypes, production, design, reflow solder. Send print or description for quote to KIT CIRCUITS, Box 235, Clawson, MI 48017.

CIRCUIT BOARDS, guaranteed lowest quotes and free twelve hour prototypes. Single and double sided boards. Small through large production quantities. Mail specifications. **Hobbyists:** any schematic, 6" x 9" maximum, etched on a 3" x 4" board—\$1.50 (larger boards—\$2.50).—Send remittance and schematic or artwork; or, print your own circuit boards. Kits of all sizes. Guaranteed lowest prices—Basic kit \$2.75; Materials for two 3" x 4" boards (included), or SASE for catalog—T.O.R.C.C. ELECTRONICS, Box 47148, Chicago, IL 60647. (312) 342-9171.

DO-IT-YOURSELF TV REPAIR

NEW ... repair any tv ... easy Anyone can do it. Write, RESEARCH, Rt3, Box 601BR, Colville, WA 99114.

RESISTORS

Resistors—any value/quantity, 1/4 watt @ \$.01, 1/2 watt @ \$.015 (\$1.00 minimum). Quantity discounts, 1,000+. Send wattage(s), value(s), quantity(s), and remittance—T.O.R.C.C. ELECTRONICS, Box 47148, Chicago, IL 60647. (312) 342-9171.

EPROM PROGRAMMING

HOBBYISTS: Pretested EPROMs sold with your programming installed. Program listing provided. Fast service. Write or call: ROMULUS MICRO-CONTROL, Box 8669, Rockville, MD, 20856. (301) 540-8863.

FREE EVALUATION and ADVISORY SERVICE



A NON PROFIT ORGANIZATION

For professional electronic technicians by prestigious non-profit organization. Earn University Degree (Bachelors or Masters) through Home Study! Credit given for previous schooling and professional experience. Upgrade your earning power. Free Details!

CONTINENTAL EDUCATION ASSOCIATES
P.O. Box 1197 - Champlain, NY 12919-1197

THE BEST PLACE to BUY, SELL or TRADE NEW and USED EQUIPMENT
NUTS & VOLTS MAGAZINE
BOX 1111-E • PLACENTIA, CA 92670
(714) 632-7721
Join Thousands of Readers Nationwide Every Month
ONE YEAR U.S. SUBSCRIPTIONS
\$10.00 - 3rd Class • \$15.00 - 1st Class
\$35.00 - Lifetime - 3rd Class

NUTS & VOLTS

HAM GEAR
COMPUTERS
SOFTWARE
SCANNERS • OPTICS
TEST EQUIPMENT
MICROWAVE
SATELLITE
AUDIO VISUAL
NEW PRODUCTS
COMPONENTS • KITS
ANTIQUE ELECT.
PUBLICATIONS
PLANS • SERVICES

WANTED

AMBITIOUS INDIVIDUALS

To operate Very profitable Electronics Assembly Business. Part time, Full time. No Experience or investment required. Excellent home business Products sold for you. **FREE** Information package

SCORPION ENTERPRISES
Station 2 Box 27
Houma, LA 70360

PAY TV and Satellite Descrambling.

73 pages of theory and schematics for all major systems. Fantasy and Anik-D schematics included. Most complete reference available on satellite scrambling \$12.95. MDS Handbook \$10. Stungun schematics \$5. Satellite systems under \$600, \$11.95. Printed circuits, kits catalog \$1.

SHOJIKI ELECTRONICS CORP. 1327R Niagara Street.
Niagara Falls, NY 14303 COD's 716-282-1001

EQUIPMENT REPORTS

continued from page 28

feet above sea level, stations as far away as 35 miles could be heard using those antennas.

The 800XLT is fairly free of birdies (self-generated spurious signals). As in other Uniden-Bearcat scanners we have used and evaluated, the birdies were primarily evident in the 40-50- and the 150-160-MHz range. However, in no instance did those present any kind of problem.

The 800XLT offers some impressive specifications, especially for equipment of its type. While we won't go into detail here, those specifications compare favorably with those of some other communications-quality gear we've recently seen.

As to the unit's instruction manual, it is clear and concise. It easily leads you through the 800XLT's features, and it offers an extra bonus on its back page: a listing of popular frequencies to help the new scanner user get started. The manual's graphics were clear and illustrated the text quite well.

On the whole, the Uniden-Bearcat 800XLT is an outstanding performer. If you're in the market for a scanning receiver with expanded frequency coverage, it should be placed near the top of your list. Undoubtedly, at a suggested list of \$499.95, the 800XLT isn't inexpensive, but you certainly get what you pay for.

R-E

THE MOST POPULAR PRODUCTS IN EUROPE & ASIA ARE COMING NOW! 50 HOT ITEMS FOR YOUR SELECTION. SEND \$1.00 FOR MARK V CATALOG, REFUND UPON ORDER

TURBO SCREW-DRIVER (RECHARGEABLE) No. 988



The most perfect powerful multi-purpose tool for Workshop, Home, Hobby & Outdoor work... Includes UL approval charger, Driver bits: 2 Regular and 2 Philips.
Each set \$30.00

CORDLESS SOLDERING IRON (RECHARGEABLE) No. 620



The most perfect handy, lightweight soldering iron for Workshop, Home, Hobby & Outdoor work... Includes UL approval charger & cleaning sponge. With build-in solder point illumination.
Each set \$22.80

TALKING CLOCK NEW FOR 86'



1. Talk: push button for voice announcement of time.
2. Read out: twelve hours system display for hour, minute, second (by color flash), AM & PM.
3. Display: three display modes of time, alarm time & date.
4. Alarm: on/off switch with thirty seconds voice alarm.
5. Snooze: reminder voice alarm of thirty seconds after 4 minutes of first voice alarm.
6. Volume: two level of voice output.
7. Language available: English.

Mynah 8504 & Cockatoo 8502 \$25.00 NOT A KIT!

LCD THERMOMETER CLOCK NEW!



Features:
0.34" DIGITAL thermometer with Hi & Low temperature alarm function and 12 hours clock combination.
Measuring range: 0°F to 160°F or -20°C to +70°C.
Resolution reading: ±1.8°F.
Dimension: 3.2" x 0.86" x 2.08".
T-1 with In/Out Door sensor \$20.00
T-2 with Fahrenheit/Celsius measuring . \$18.00 NOT A KIT!

YAMATO 4001 3 1/2 DIGITAL MULTIMETER



SPECIAL OFFER!

The YAMATO 4001 is a 3 1/2 DIGIT COMPACT DIGITAL MULTIMETER, it employs FE type LCD, with large figures. Its ADVANTAGES: High accuracy in measuring. High impedance assures min. measuring error. One rotary switch allows fast & convenient operation. 26 measurement range enable wider application. Over-input indication & low battery life appears on display. LSI-circuit use provides high reliability and durability. Measurement possible even under strong magnetic field.
Not a KIT, assembled with tested \$33.80

150MC UNIVERSAL DIGITAL FREQUENCY COUNTER SM-100

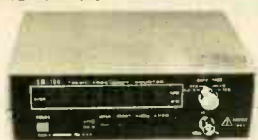

SM-100 is an accurate, easy-operated digital frequency counter. Few pieces of advanced, high technical LSI integrated circuit are used, thus, circuit structure is reliable. SM-100 can give you up to 8 digits of resolution for a wide frequency range of 10Hz to 150MHz. Besides, a memorize system is available, the last input digits can be held on the panel, as compare to the other or even observation.
Input sensitivity: KHz range 10Hz - 10MHz 50mVrms
MHz range 1MHz - 150MHz 40mVrms
Response time: 0.2 sec.
Hold: Hold the last input signal
Power supply: DC6V Battery or DC9V 250MA Adaptor
Assembled with Tested \$99.00

TA-302 60W VERSATILE STEREO POWER BOOSTER



- * OTL full transistorize and low distortion of SEPP circuit design, high output power and sound fidelity.
- * With high and low input impedance for selection, so it can match with all pre-amplifiers, low power of portable sound equipment, and all types of stereo recorder deck to use. It can boost 'walkman' type of radio and tape player, too.
- * With 10 band colour LED power meter, output power can be easily defined. TA-302 is a versatile amplifier for both visual and listening enjoyment.

Assembled with Tested \$60.00
Kit \$50.00

SM-43 MULTIFUNCTIONAL LED D.P.M.



6 different kinds of usages with only one meter, high accuracy (±0.1%) (±1 digit), high input impedance, high anti-vibrating ability, the display reset to zero automatically when the input is OV and employs 100PPM/°C temperature compensating zener diode which improves the accuracy and stationarity of the meter.
MEASUREMENT RANGE:
D.C. VOLTAGE: 1mV - 1000V
A.C. VOLTAGE: 1mV - 1000V
DIGITAL THERMOMETER: 0°C - 100°C
D.C. CURRENT: 1uA - 2A
CAPACITOR METER: 1pF - 2uF
FREQUENCY COUNTER: 10Hz - 20KHz
DIMENSION: 3 3/4" x 1 7/8" x 4 1/16"
Kit \$29.23
Assembled with tested \$35.00

TY-38 SOUND OR TOUCH CONTROL SWITCH



When there is a sound input, the switch is on, otherwise the switch is off.
High precision timing circuit makes it possible to adjust delay from 0.5 second to 15 seconds.
Suitable for CB transmitter.
When touching plate is pressed, the switch is on, otherwise it is off.
High precision delay circuit is included.
Power supply: 9-16V DC.
Kit \$10.00

PRACTICAL & DECORATIVE TWO-PIECE PHONE HT-10



- * Ultra-slim desk top style.
- * Last number memory redial.
- * 10 memories function.
- * Two colors available: Red & Gray.

FCC approved No. DEW7DH-15793-TE-R.
Each Set \$39.90

TA-2400A ELECTRONIC ECHO AND REVERBERATION AMPLIFIER



REMIX your record yourself

This unit combines the most advanced computer V.L.S.I. technique with high quality Japan Made component, so it has the following FEATURES:
It can generate various reflection and reverberation effect such as that in valley and music hall. It has a 3 section effect control which includes reverberation control, delay control and depth control. Special effect can be made in your record tapes by using this model. All kinds of infield sound effect can be obtained by skilful use of this control. It has LED display to show reflection and reverberation.
Ass. with tested \$99.85

TA-2500 HIGH QUALITY MULTIPURPOSE PRE-AMPLIFIER



This specially designed pre-amplifier includes a professional GRAPH EQUALIZER TONE control system and has a gain to 12dB. Frequency response extends from 5Hz to 20KHz, so even in bad listening condition it can improve well. It can accept input from various magnetic cartridge, record deck and tuner, its output can be connected to all kinds of power amplifier! The following combinations are good examples.
Assembled with tested \$90.00

TY-23B COLOR LIGHT CONTROLLER



As a result of the advanced technology, this unit can control various colorful light bulbs, the visual effect of which is most suitable in places like party, disco, electronic game centre and also in lightings for advertisement. Total output power is 3000W (1000W/Ch.) which means that it can control 30 pieces of 100W or 600 pieces of 5W color light which is enough for most usages.
Kit \$65.00
Ass. with tested \$75.00

TY-36 AC/DC QUARTZ DIGITAL CLOCK



The reference frequency is derived from a circuit consisting of 3579545 KC quartz crystal and MM 5369 IC so it is very precise and will never be affected by mains frequency. It also includes a Fast/Slow trimmer.
It uses 0.6" LED display panel so the display is more clear and readable.
Specially designed dual-tone alarm sounds beautiful and attracting. An electronic buzzer is supplied free of charge. The power supply is DC 12V/0.2A, or AC 9V x 20.5A.
Kit \$16.92

TERMS:

Min order: \$10.00
Charge card order: \$20.00
NO C. O. D. ! Cashier's check, phone orders accept.
Calif. Res Add 6.5% Sales Tax.
Prices are subject to change without notice.

All merchandises are subject to prior sale.
Shipping & Handling: Inside L. A. 5% of total order (Min 1.50). Outside L. A. 10% of total order (Min 2.50). Outside U.S.A. 20% of total order (Min 5.00).
Shipped by UPS



HOURS: MON - FRI 10:00 TO 5:00
SATURDAYS 9:00 TO 12:00

MARK V ELECTRONICS INC.
248 E. Main Street,
Suite 100,
Alhambra, CA91801
Information (818) 282-1130
Orders (818) 282-1196
P. O. Box 7422 ALHAMBRA, CA 91802
TELEX: 3716914 MARK 5

This publication is available in microform.



University
Microfilms
International

University Microfilms International reproduces this publication in microform: microfiche and 16mm or 35mm film. For information about this publication or any of the more than 13,000 titles we offer, complete and mail the coupon to: University Microfilms International, 300 N. Zeeb Road, Ann Arbor, MI 48106. Call us toll-free for an immediate response: 800-521-3044. Or call collect in Michigan, Alaska and Hawaii: 313-761-4700.

Please send information about these titles:

Name _____

Company/Institution _____

Address _____

City _____

State _____ Zip _____

Phone () _____

ALL SALES SUBJECT TO THE TERMS OF OUR 90 DAY LIMITED WARRANTY. FREE COPY UPON REQUEST.

SOLAR CELL SPECIAL: 4 In. Diameter Rated .45 VDC At 1.2 Amps Or Better. Brand New Units, Cosmetic Seconds, But Perfect Electrically. \$3.99 6/\$20.

THE NEW ZRT-80 CRT TERMINAL BOARD!

A LOW COST Z-80 BASED SINGLE BOARD THAT ONLY NEEDS AN ASCII KEYBOARD, POWER SUPPLY, AND VIDEO MONITOR TO MAKE A COMPLETE CRT TERMINAL. USE AS A COMPUTER CONSOLE, OR WITH A MODEM FOR USE WITH ANY OF THE PHONE-LINE COMPUTER SERVICES.

FEATURES:

- Uses a Z80A and 6845 CRT Controller for powerful video capabilities.
- RS232 at 16 BAUD Rates from 75 to 19,200.
- 24 x 80 standard format (60 Hz).
- Optional formats from 24 x 80 (50 Hz) to 64 lines x 96 characters (60 Hz).
- Higher density formats require up to 3 additional 2K x 8 6116 RAMS.
- Uses N.S. INS 8250 BAUD Rate Gen. and USART combo IC.
- 3 Terminal Emulation Modes which are Dip Switch selectable. These include the LSI-ADM3A, the Heath H-19, and the Beehive.
- Composite or Split Video.
- Any polarity of video or sync.
- Inverse Video Capability.
- Small Size: 6.5 x 9 inches.
- Upper & lower case with descenders.
- 7 x 9 Character Matrix.
- Requires Par. ASCII keyboard.

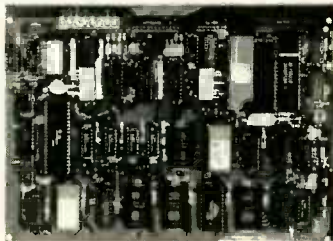

\$89⁹⁵

#ZRT-80
(COMPLETE KIT, 2K VIDEO RAM)

BLANK PCB WITH 2716

CHAR. ROM. 2732 MON. ROM

\$49⁹⁵

SOURCE DISKETTE - ADD \$10

SET OF 2 CRYSTALS - ADD \$7.50

FOR 8 IN.
SOURCE DISK
(CP/M COMPATIBLE)
ADD \$10

Digital Research Computers (OF TEXAS)

P.O. BOX 381450 • DUNCANVILLE TX 75138 • (214) 225-2309

Call or write for a free catalog on Z-80 or 6809 Single Board Computers, SS-50 Boards, and other S-100 products.

TERMS: Add \$3.00 postage. We pay balance. Orders under \$15 add 75¢ handling. No C.O.D. We accept Visa and MasterCard. Texas Res. add 5-1/8% Tax. Foreign orders (except Canada) add 20% P & H. Orders over \$50 add 85¢ for insurance.

AMAZING DEVICES

PERSONAL DEFENSE AND PROPERTY PROTECTION UTILIZE SPACE AGE TECHNOLOGY. CAUTION THESE DEVICES CAN BE HAZARDOUS AND MAY SOON BE ILLEGAL.

PHASORS

POCKET PAIN FIELD GENERATOR — IPG50
Assembled \$64.50
IPG5 Plans \$8.00 IPG5K Kit/Plans \$44.50

PHASOR PAIN FIELD CROWD CONTROLLER — PPF10
Assembled \$250.00
PPF1 Plans \$15.00 PPF1K Kit/Plans \$175.00

BLASTER - Provides a plasma discharge capable of puncturing a can. Produces a 100,000 WATT PULSE.
BLS10 ASSEMBLED \$89.50
BLS1 PLANS \$10.00 BLS1K KIT/PLANS \$69.50

PLASMA STUN GUN - Very intimidating and affective 5 to 10 feet 100,000 VOLTS
ITM10 ASSEMBLED \$99.50
ITM1 PLANS \$10.00 ITM1K KIT/PLANS \$69.50

RUBY LASER RAY GUN — Intense visible red beam burns and welds hardest of metals. **MAY BE HAZARDOUS.**

RUB3 All Parts Available for Completing Device \$20.00
CARBON DIOXIDE BURNING, CUTTING LASER — Produces a continuous beam of high energy. **MAY BE HAZARDOUS.**

LCS. All Parts Available for Completing Device \$20.00
VISIBLE LASER LIGHT GUN — produces intense red beam for sighting, spotting, etc. Hand held complete.
LGU3 Plans \$10.00 (Kit & Assembled Units Available)
IR PULSED LASER RIFLE — Produces 15-30 watt infra-red pulses at 200-2000 per sec
LRG3 All Parts & Diodes Available \$10.00

BEGINNERS LOW POWER VISIBLE LASER — Choice of red, yellow, green — provides an excellent source of monochromatic light.
LHC2 Plans \$5.00 LHC2K Kit \$34.50

SNOOPER PHONE — Allows user to call his premises and listen in without phone ever ringing.
SNP20 Assembled \$89.50
SNP2 Plans \$9.00 SNP2K Plans/Kit \$59.50

LONG RANGE WIRELESS MIKE — Miniature device clearly transmits well over one mile. Super sensitive, powerful.
MFT1 Plans \$7.00 MFT1K Plans/Kit \$49.50

WIRELESS TELEPHONE TRANSMITTER — Transmits both sides of phone conversation over one mile, shuts off automatically.
VWPM5 Plans \$8.00 VWPM5K Plans/Kit \$39.50

PWM5—LONG RANGE SUPER EAR WITH WIRELESS ATTACHMENT
PWM5 Plans \$10.00 PWM5K Kit \$139.50
PWM50 Assembled and Tested \$169.50

Our phone is open for orders anytime. Technicians are available 9-11 a.m. Mon-Thurs for those needing assistance or information. Send \$1.00 for catalog of hundreds more similar devices. Send check, cash, MO, Visa, MC, COD to: **INFORMATION UNLIMITED**
DEPT R8 P.O. Box 716, Amherst, N. H. 03031 Tel: 603-673-4730

CIRCLE 72 ON FREE INFORMATION CARD



One tree can make
3,000,000 matches.



One match can burn
3,000,000 trees.



A Public Service of This Magazine
& The Advertising Council

RADIO-ELECTRONICS

VISA
 NATIONAL SEMICONDUCTOR • PANASONIC
 OK MACHINE • EWC, INC. • INTERSIL • AD
 EAC, INC. • J. W. MILLER • AAVI ENGINEER
 E. F. JOHNSON • ATLANTIC SEMICONDUCTOR

256K (262,144 x 1) DRAM 150NS \$5.70/1; \$39.95/9
Factory Firsts

DIODES • DIAMOND TOOL • UNGAR • ES • CW INDUSTRIES • AMDEK • G.E. JGAR • YAGED • J. W. MILLER • LUXO • 3C CHEMICALS • ARIES • PLESSEY

INTEGRATED CIRCUITS

Part No.	Description	Part No.	Description
7400 TTL	74151N	74250N	74151N
7401N	74152N	74251N	74152N
7402N	74153N	74252N	74153N
7403N	74154N	74253N	74154N
7404N	74155N	74254N	74155N
7405N	74156N	74255N	74156N
7406N	74157N	74256N	74157N
7407N	74158N	74257N	74158N
7408N	74159N	74258N	74159N
7409N	74160N	74259N	74160N
7410N	74161N	74260N	74161N
7411N	74162N	74261N	74162N
7412N	74163N	74262N	74163N
7413N	74164N	74263N	74164N
7414N	74165N	74264N	74165N
7415N	74166N	74265N	74166N
7416N	74167N	74266N	74167N
7417N	74168N	74267N	74168N
7418N	74169N	74268N	74169N
7419N	74170N	74269N	74170N
7420N	74171N	74270N	74171N
7421N	74172N	74271N	74172N
7422N	74173N	74272N	74173N
7423N	74174N	74273N	74174N
7424N	74175N	74274N	74175N
7425N	74176N	74275N	74176N
7426N	74177N	74276N	74177N
7427N	74178N	74277N	74178N
7428N	74179N	74278N	74179N
7429N	74180N	74279N	74180N
7430N	74181N	74280N	74181N
7431N	74182N	74281N	74182N
7432N	74183N	74282N	74183N
7433N	74184N	74283N	74184N
7434N	74185N	74284N	74185N
7435N	74186N	74285N	74186N
7436N	74187N	74286N	74187N
7437N	74188N	74287N	74188N
7438N	74189N	74288N	74189N
7439N	74190N	74289N	74190N
7440N	74191N	74290N	74191N
7441N	74192N	74291N	74192N
7442N	74193N	74292N	74193N
7443N	74194N	74293N	74194N
7444N	74195N	74294N	74195N
7445N	74196N	74295N	74196N
7446N	74197N	74296N	74197N
7447N	74198N	74297N	74198N
7448N	74199N	74298N	74199N
7449N	74200N	74299N	74200N

TI IC SOCKETS

Part No.	Description	Part No.	Description
SO1	8-pin DIP	SO18	18-pin DIP
SO2	14-pin DIP	SO19	24-pin DIP
SO3	16-pin DIP	SO20	28-pin DIP
SO4	18-pin DIP	SO21	32-pin DIP
SO5	20-pin DIP	SO22	36-pin DIP
SO6	24-pin DIP	SO23	40-pin DIP
SO7	28-pin DIP	SO24	44-pin DIP
SO8	32-pin DIP	SO25	48-pin DIP
SO9	36-pin DIP	SO26	52-pin DIP
SO10	40-pin DIP	SO27	56-pin DIP
SO11	44-pin DIP	SO28	60-pin DIP
SO12	48-pin DIP	SO29	64-pin DIP
SO13	52-pin DIP	SO30	68-pin DIP
SO14	56-pin DIP	SO31	72-pin DIP
SO15	60-pin DIP	SO32	76-pin DIP
SO16	64-pin DIP	SO33	80-pin DIP
SO17	68-pin DIP	SO34	84-pin DIP
SO18	72-pin DIP	SO35	88-pin DIP
SO19	76-pin DIP	SO36	92-pin DIP
SO20	80-pin DIP	SO37	96-pin DIP
SO21	84-pin DIP	SO38	100-pin DIP
SO22	88-pin DIP	SO39	104-pin DIP
SO23	92-pin DIP	SO40	108-pin DIP
SO24	96-pin DIP	SO41	112-pin DIP
SO25	100-pin DIP	SO42	116-pin DIP
SO26	104-pin DIP	SO43	120-pin DIP
SO27	108-pin DIP	SO44	124-pin DIP
SO28	112-pin DIP	SO45	128-pin DIP
SO29	116-pin DIP	SO46	132-pin DIP
SO30	120-pin DIP	SO47	136-pin DIP
SO31	124-pin DIP	SO48	140-pin DIP
SO32	128-pin DIP	SO49	144-pin DIP
SO33	132-pin DIP	SO50	148-pin DIP
SO34	136-pin DIP	SO51	152-pin DIP
SO35	140-pin DIP	SO52	156-pin DIP
SO36	144-pin DIP	SO53	160-pin DIP
SO37	148-pin DIP	SO54	164-pin DIP
SO38	152-pin DIP	SO55	168-pin DIP
SO39	156-pin DIP	SO56	172-pin DIP
SO40	160-pin DIP	SO57	176-pin DIP
SO41	164-pin DIP	SO58	180-pin DIP
SO42	168-pin DIP	SO59	184-pin DIP
SO43	172-pin DIP	SO60	188-pin DIP
SO44	176-pin DIP	SO61	192-pin DIP
SO45	180-pin DIP	SO62	196-pin DIP
SO46	184-pin DIP	SO63	200-pin DIP
SO47	188-pin DIP	SO64	204-pin DIP
SO48	192-pin DIP	SO65	208-pin DIP
SO49	196-pin DIP	SO66	212-pin DIP
SO50	200-pin DIP	SO67	216-pin DIP
SO51	204-pin DIP	SO68	220-pin DIP
SO52	208-pin DIP	SO69	224-pin DIP
SO53	212-pin DIP	SO70	228-pin DIP
SO54	216-pin DIP	SO71	232-pin DIP
SO55	220-pin DIP	SO72	236-pin DIP
SO56	224-pin DIP	SO73	240-pin DIP
SO57	228-pin DIP	SO74	244-pin DIP
SO58	232-pin DIP	SO75	248-pin DIP
SO59	236-pin DIP	SO76	252-pin DIP
SO60	240-pin DIP	SO77	256-pin DIP
SO61	244-pin DIP	SO78	260-pin DIP
SO62	248-pin DIP	SO79	264-pin DIP
SO63	252-pin DIP	SO80	268-pin DIP
SO64	256-pin DIP	SO81	272-pin DIP
SO65	260-pin DIP	SO82	276-pin DIP
SO66	264-pin DIP	SO83	280-pin DIP
SO67	268-pin DIP	SO84	284-pin DIP
SO68	272-pin DIP	SO85	288-pin DIP
SO69	276-pin DIP	SO86	292-pin DIP
SO70	280-pin DIP	SO87	296-pin DIP
SO71	284-pin DIP	SO88	300-pin DIP
SO72	288-pin DIP	SO89	304-pin DIP
SO73	292-pin DIP	SO90	308-pin DIP
SO74	296-pin DIP	SO91	312-pin DIP
SO75	300-pin DIP	SO92	316-pin DIP
SO76	304-pin DIP	SO93	320-pin DIP
SO77	308-pin DIP	SO94	324-pin DIP
SO78	312-pin DIP	SO95	328-pin DIP
SO79	316-pin DIP	SO96	332-pin DIP
SO80	320-pin DIP	SO97	336-pin DIP
SO81	324-pin DIP	SO98	340-pin DIP
SO82	328-pin DIP	SO99	344-pin DIP
SO83	332-pin DIP	SO100	348-pin DIP

DISC CAPACITORS

Part No.	Cap.	Volt.	Price
PA100	100 pF	50V	0.45
PA101	100 pF	75V	0.49
PA102	100 pF	100V	0.53
PA103	100 pF	150V	0.61
PA104	100 pF	200V	0.69
PA105	100 pF	250V	0.77
PA106	100 pF	300V	0.85
PA107	100 pF	350V	0.93
PA108	100 pF	400V	1.01
PA109	100 pF	450V	1.09
PA110	100 pF	500V	1.17
PA111	100 pF	550V	1.25
PA112	100 pF	600V	1.33
PA113	100 pF	650V	1.41
PA114	100 pF	700V	1.49
PA115	100 pF	750V	1.57
PA116	100 pF	800V	1.65
PA117	100 pF	850V	1.73
PA118	100 pF	900V	1.81
PA119	100 pF	950V	1.89
PA120	100 pF	1000V	1.97

74HC00 CMOS

Part No.	Description	Part No.	Description
74HC00	NAND	74HC01	NOT
74HC02	NAND	74HC03	NOT
74HC04	NOT	74HC05	NOT
74HC06	NOT	74HC07	NOT
74HC10	SCHMITT	74HC11	SCHMITT
74HC12	SCHMITT	74HC13	SCHMITT
74HC14	SCHMITT	74HC15	SCHMITT
74HC16	SCHMITT	74HC17	SCHMITT
74HC18	SCHMITT	74HC19	SCHMITT
74HC20	MONO	74HC21	MONO
74HC22	MONO	74HC23	MONO
74HC24	MONO	74HC25	MONO
74HC26	MONO	74HC27	MONO
74HC28	MONO	74HC29	MONO
74HC30	MONO	74HC31	MONO
74HC32	MONO	74HC33	MONO
74HC34	MONO	74HC35	MONO
74HC36	MONO	74HC37	MONO
74HC38	MONO	74HC39	MONO
74HC40	MONO	74HC41	MONO
74HC42	MONO	74HC43	MONO
74HC44	MONO	74HC45	MONO
74HC46	MONO	74HC47	MONO
74HC48	MONO	74HC49	MONO
74HC50	MONO	74HC51	MONO
74HC52	MONO	74HC53	MONO
74HC54	MONO	74HC55	MONO
74HC56	MONO	74HC57	MONO
74HC58	MONO	74HC59	MONO
74HC60	MONO	74HC61	MONO
74HC62	MONO	74HC63	MONO
74HC64	MONO	74HC65	MONO
74HC66	MONO	74HC67	MONO
74HC68	MONO	74HC69	MONO
74HC70	MONO	74HC71	MONO
74HC72	MONO	74HC73	MONO
74HC74	MONO	74HC75	MONO
74HC76	MONO	74HC77	MONO
74HC78	MONO	74HC79	MONO
74HC80	MONO	74HC81	MONO
74HC82	MONO	74HC83	MONO
74HC84	MONO	74HC85	MONO
74HC86	MONO	74HC87	MONO
74HC88	MONO	74HC89	MONO
74HC90	MONO	74HC91	MONO
74HC92	MONO	74HC93	MONO
74HC94	MONO	74HC95	MONO
74HC96	MONO	74HC97	MONO
74HC98	MONO	74HC99	MONO
74HC100	MONO	74HC101	MONO
74HC102	MONO	74HC103	MONO
74HC104	MONO	74HC105	MONO
74HC106	MONO	74HC107	MONO
74HC108	MONO	74HC109	MONO
74HC110	MONO	74HC111	MONO
74HC112	MONO	74HC113	MONO
74HC114	MONO	74HC115	MONO
74HC116	MONO	74HC117	MONO
74HC118	MONO	74HC119	MONO
74HC120	MONO	74HC121	MONO
74HC122	MONO	74HC123	MONO
74HC124	MONO	74HC125	MONO
74HC126	MONO	74HC127	MONO
74HC128	MONO	74HC129	MONO
74HC130	MONO	74HC131	MONO
74HC132	MONO	74HC133	MONO
74HC134	MONO	74HC135	MONO
74HC136	MONO	74HC137	MONO
74HC138	MONO	74HC139	MONO
74HC140	MONO	74HC141	MONO
74HC142	MONO	74HC143	MONO
74HC144	MONO	74HC145	MONO
74HC146	MONO	74HC147	MONO
74HC148	MONO	74HC149	MONO
74HC150	MONO	74HC151	MONO
74HC152	MONO	74HC153	MONO
74HC154	MONO	74HC155	MONO
74HC156	MONO	74HC157	MONO
74HC158	MONO	74HC159	MONO
74HC160	MONO	74HC161	MONO
74HC162	MONO	74HC163	MONO
74HC164	MONO	74HC165	MONO
74HC166	MONO	74HC167	MONO
74HC168	MONO	74HC169	MONO
74HC170	MONO</		

Mail-Order Electronics
415-592-8097

CALL FOR QUANTITY DISCOUNTS

Table with columns: Part No., Price, and various part numbers under the heading '7400'.

Table with columns: Part No., Price, and various part numbers under the heading '74LS'.

Table with columns: Part No., Price, and various part numbers under the heading '74S/PROMS'.

Table with columns: Part No., Price, and various part numbers under the heading '74F'.

Table with columns: Part No., Price, and various part numbers under the heading 'CD-CMOS'.

SPECIAL!! SPECIAL!! SPECIAL!! SPECIAL!!

MOTOROLA MC68701 - Microcomputer with EPROM. Features: 8-bit single chip microcomputer unit (MCU) which significantly enhances the capabilities of the MC6800 family of parts.

Table listing custom commodity chips for VIC-20, C-64, and C-128 Personal Computers. Columns include Part No., Description, Price, and various chip models.

MICROPROCESSOR COMPONENTS

Table listing microprocessor chips and dynamic RAMs. Columns include Part No., Description, Price, and various chip models like 8086, 8088, 8080, etc.

6500/6800/6800 SERIES

Table listing various microprocessors from the 6500/6800 series, including 6502, 6505, 6506, etc.

BIOS/ROM SERIES

Table listing BIOS and ROM chips, including 8031, 8032, 8033, etc.

74H

Table listing various 74H series components, including 74H00, 74H01, 74H02, etc.

EEPROM

2816A 24 2048x8 16K EPROM 350ns. \$8.95. Features: On-board Address/Data Latches - Auto-Timed Byte Write (on chip) time - 3V-5V Voltage Range - Optional High Voltage Erasable (9V-18V) - Power Up/Down Write Protection - Auto Erase before Write.

Digitalker™. DT1050 - assembly, factory pre-tested, complete, plug-and-play, microcomputer, and/or interface kit. Includes 133 standard DIGITALKer™ or encoded with 133 software and user's manuals, 2 lines, and 5 different screen durations.

DT1050 Digitalker™ \$24.95 ea.

MT54104 Processor Chip. \$12.95 ea.

DT1057 - Exports the DT1050 necessary from 133 to over 750 words. \$11.95 ea.

INTERFIL

30009 1985 Interfil Data Book (1075 pp.) \$9.95

74HC HIGH SPEED CMOS

Table listing 74HC series components, including 74HC00, 74HC01, 74HC02, etc.

74C-C/MOS

Table listing 74C-C/MOS series components, including 74C00, 74C01, 74C02, etc.

LINEAR

Table listing linear components, including LM7400, LM7401, LM7402, etc.

30003 1982 Nat. Linear Data Book (1952 pp.) \$14.95

74L

Table listing various 74L series components, including 74L00, 74L01, 74L02, etc.

74L

Table listing various 74L series components, including 74L00, 74L01, 74L02, etc.

Worldwide • Since 1974

• QUALITY COMPONENTS • COMPETITIVE PRICING • PROMPT DELIVERY

Mall Order Electronics • Worldwide
Jameco
 ELECTRONICS

Commodore® Accessories

RS232 Adapter for VIC-20 and Commodore 64

The JE232C allows connection of standard serial RS232 printers, modems, etc. to your VIC-20 and C-64. A 4-pole switch allows the inversion of the 4 control lines. Complete installation and operation instructions included.

- Plugs into User Port
- Provides Standard RS232 signal levels
- Uses 6 signals (Transmit, Receive, Clear to Send, Request to Send, Data Terminal Ready, Data Set Ready).

JE232CM \$39.95

VOICE SYNTHESIZER FOR COMMODORE VIC-20 AND C-64
 Plug-In - Talking in Minutes!

JE520CM \$99.95

300 BAUD AUTO MODEM Mitey-Mo (For C-64) \$74.95

PARALLEL PRINTER INTERFACE
 FREE 4K Buffer Included!

MW350 (For VIC-20, C-64 & C-128) \$69.95

TRS-80 Accessories

EXPAND TRS-80 MEMORY TRS-80 MODEL I, III

Each Kit complete with eight MM5290 (UPD4164) 16K Dynamic RAMs and documentation for conversion. Model I 16K equipped with Expansion Interface can be expanded to 48K with 2 Kits. Model III can be expanded from 16K to 48K using 2 Kits. Each Kit will expand computer by 16K increments.

TRS-16K3 200ns (Model III) \$5.95
TRS-16K4 250ns (Model I) \$5.49

TRS-80 COLOR AND COLOR II

Easy to install Kit complete with 8 each 4164N-20 (200ns) 64K Dynamic RAMs and documentation for conversion. Converts TRS-80 Color Computers with D, E, F and NC circuit boards to 32K. Also converts TRS-80 Color Computer II to 64K. Flex DOS or OS-9 required to utilize full 64K RAM on all computers.

TRS-64K-2 \$9.95

TRS-80 MODEL 4, 4P

Easy to install Kits complete with TRS-64K-2 (8 ea. 4164N-20 (200ns) 64K Dynamic RAMs), TRS-64K-2PAL (8 ea. 4164A plus PAL chip) and documentation for conversion.

TRS-64K-2 \$9.95
Model 4P from 64K to 128K \$29.95
TRS-64K-2PAL \$29.95
Expands Model 4 from 64K to 128K \$29.95

• TRS-80 Model 100 • NEC • Olivetti

Easy to install Module plugs right into the socket increasing memory in 8K increments. Three modules will increase your memory to its full capacity. Complete with module and documentation for installation.

MY08K (TRS-80 Model 100 Expansion) \$29.95 ea. or 3/\$79.95
NEC8KR (NEC PC-4201A) \$29.95 ea. or 3/\$79.95
OM108K (Olivetti M10) \$29.95 ea. or 3/\$79.95

TANDY 200

Easy to install module plugs right into the socket increasing memory in 24K increments. Complete with module and documentation for installation.

M200R (Tandy 200 Expansion) \$99.95 ea. or 2/\$189.95

PROMETHEUS MODEMS

Intelligent 1200/300 Baud Modem with Real Time Clock/Calendar

The ProModem™ is a Bell 212A (1200/300) Intelligent stand-alone modem. Hayes command set compatible plus an additional extended command set. Shows with alphanumeric display option.

PM1200 RS-232 Stand-Alone Unit \$299.95

OPTIONS FOR ProModem 1200

PM-COM (ProCom Communication Software) \$ 79.95
 Please specify Operating System - Apple, ProDOS or CP/M - or IBM, PC DOS or MS DOS

PM-OPS12K (12K Memory for PM-OPS12K) \$ 54.95
PM-ALP (Alphanumeric Display) \$ 79.95

PM-Serial#2 (Includes PM-OPS12K, BUFS12K and PM-ALP) \$249.95

The ProModem 1200B/BS is a 1200/300 baud modem card which plugs into IBM PC and XT. Provides a third serial port. Two versions available: 1200B (without software) and 1200BS (with software). The PM1200BS is supplied with powerful MITE communications software from Mycroft Labs. Software available: PC DOS or MS DOS.

PM1200B (without software) \$239.95
PM1200BS (with MITE Software) \$274.95

Muffin-Style & Sprite-Style Fans

MUF60 (SPN3-15-2462) Howard Industries (4.65" sq, 60cm) \$9.95
SU2C7 EG&G Rotron (3.125" sq, 20 cfm) \$9.95

APPLE® COMPATIBLE COMPUTER ACCESSORIES

Five Key Software Programs! For Apple II, II+ and IIe*

The JE888 is functionally compatible with the Apple II language card and can be utilized with all software that can be used with a standard 16K card. The JE888 requires no modifications to your Apple computer. Five key software programs are included: Memory Management System, Utilities, diagnostics, demos, and RAM disk emulators for DOS 3.3, CP/M and Apple Pascal. Also features DOS relocater. Complete with instructions. **Note: CP/M versions 2.2 or earlier - PASCAL - versions 1.1 or earlier!**

JE888 (Expand-A-RAM) \$119.95

Applesurance Diagnostic Disk Controller Card Prevents Crashes! For Apple II, II+ and IIe*

The JE877 serves as a diagnostic tool, an assurance maintenance tool and a dual disk drive controller. The JE877 will verify and check the operating hardware of your system each time you turn on your Apple II, II+ or IIe. Test your RAM, ROM (PROM) and disk drives. Diagnostic routines may be canceled at the touch of a key. Complete with instructions.

JE877 (DRV-1/Applesurance II) \$69.95

Parallel Printer Card For Apple II, II+ and IIe*

The JE880 Printer interface board is an intelligent interface to most of today's popular dot matrix graphics printers. The JE880 is fully compatible with Apple CP/M, Apple Pascal for FORTRAN, and most other operating systems and software packages available for Apple II, II+ and IIe. The JE880 is shipped configured for the Centronics standard and can be re-configured for other standards if necessary. Advanced test printing features include: video screen echo ON or OFF, auto-disable linefeed after carriage return, set/clear the bit of the output data, set left margin and more! Complete with instructions.

JE880 (PRT-1) \$59.95

Parallel/Serial Buffer Card For Apple II, II+ and IIe*

The JE883 provides the user with up to 64K of additional or buffered memory (18 pages of information). Using the parallel jumper cable supplied, the JE883 will attach to the JE880 (above). Parallel Card needed for operation. The JE883 includes a standard parallel input with both parallel and serial (RS232) buffered outputs. With these features you may access and buffer information to two types of printers (one serial, one parallel) simultaneously. Complete with instructions.

JE883 (P/S Buffer) \$79.95

APPLE® Compatible 5 1/4" Half-Height Disk Drive For Apple II, II+ and IIe*

ONLY \$129.95

APPLE® Compatible 5 1/4" Disk Drive and Controller Card for Apple II, II+ and IIe*

- Ball driven - 143K formatted storage - Color matches Apple Computer - Works with Apple Controller or other Apple-compatible controllers (JE875) - Complete with connectors - Just plug into your disk controller card - 35 tracks - Size: 6 1/2" x 3 1/4" x 8-9/16" - Weight: 4 lbs.

ADD-514 (Disk Drive) \$139.95
JE875 (Controller Card) \$ 49.95

APPLE® II/c Compatible 5 1/4" Half-Height Disk Drive

Same specs as ADD-12 except no controller necessary.

ADD-11c \$129.95

Additional Apple® Compatible Products

- Key: a = Apple II or II+ b = Apple IIe
- APF-1 Cooling Fan with surge protection - Key: (a, b) \$ 39.95
 - KHP4007 Switching Power Supply - Key: (a, b) \$ 39.95
 - JE614 Numeric/Aux. Keypad - 11 accessible functions - Key: (b) \$ 49.95
 - JE860 16K RAM Card (Note: CP/M Versions 2.2 or earlier) - Key: (a) \$ 39.95
 - JE864 80-Column plus 64K RAM - Key: (b) \$ 69.95
 - AMON 12" Green Monitor with swivel stand - Key: (a, b & IIc) \$ 99.95
 - KB-EA1 Apple Keyboard and Case - Key: (a) \$ 99.95
 - JE520AP Voice Synthesizer - Plug-In, User Ready - Key: (a, b) \$119.95
 - PM1200A Prometheus Internal Modem - 2 cards - Key: (a, b) \$299.95
 - PM1200M Prometheus Macintosh Ext. Modem - Key (Macintosh) \$349.95

General Application Power Supplies

Power/Mate Corp. REGULATED POWER SUPPLY

Input: 105-125/210-250VAC @ 47-63Hz. Line regulation: ±0.05%. Three mounting surfaces. Overvoltage protection. UL recognized - CSA certified.

Part No.	Output	Size	Weight	Price
EMAS/6B	5V @ 3A/6V @ 2.5A	4 1/4" x 4 1/4" x 2 1/4" H	2lbs.	\$29.95
EMAS/6C	5V @ 6A/6V @ 5A	5 1/4" x 4 1/4" x 2 1/4" H	4lbs.	\$39.95

1-CHANNEL SWITCHING POWER SUPPLY

Microprocessor, mini-computer, terminal, medical equipment and process control applications. Input: 90-130VAC, 47-440Hz. Output: +5VDC @ 5A, -5VDC @ 1A, +12VDC @ 1A, -12VDC @ 1A. Line regulation: ±0.2%. Ripple: 30mV p-p. Load regulation: ±1%. Overcurrent protection. Adj. 5V main output ±10%. Size: 5 1/2" x 1 1/2" x 4-15/16" H. Weight: 1 1/2 lbs.

FCS-604A \$59.95

DATA BOOKS

- 30009 Intel Data Book (1985) \$9.95
- 30013 Zilog Data Book (1985) \$9.95
- 210830 Intel Memory Components Hndbk. (1983/84) \$14.95
- 230843 Intel Microsystem Components Hndbk. (1983/84) \$19.95
- 30022 National Logic Data Book Set (1984) \$24.95

IBM® Accessories

IBM PC/XT Compatible Keyboard

IBM-5151 (Equivalent to Keytronic's 5151) \$129.95

Additional Add-Ons Available!

IBM-Case	Computer Case	\$ 59.95
IBM-KB	Keyboard	\$ 79.95
IBM-FCC	Disk Controller	\$ 79.95
IBM-MCC	Monochrome Card	\$ 99.95
IBM-MON	12" Monochrome Monitor	\$109.95
IBM-ICB	Color Card w/Printer Port	\$149.95
IBM-E384K	384K RAM Card	\$199.95
IBM-MB	Motherboard	\$349.95
IBM-10MBK	10MB HH Hard Kit	\$599.95
IBM-20MBK	20MB HH Hard Kit	\$799.95

IBM PCXT Equivalent 130 Watt Power Supply
 UPGRADE YOUR PCI

- Input: 110V @ 60Hz - Output: +5VDC @ 15A, -5VDC @ 0.5A, +12VDC @ 4.2A, -12VDC @ 0.5A - Plug compatible connectors - Fits into IBM PC - Weight: 6 lbs.

IBM-PS \$99.95

IBM Compatible! DISK DRIVES

Documentation Included

- RFD480 (Remex 5 1/4" DS full-ht.) \$69.95
- FD55B (Teac 5 1/4" DS half-ht.) \$99.95
- SA455 (Shugart 5 1/4" DS half-ht.) \$99.95
- TM100-2 (Tandon 5 1/4" DS full-ht.) \$99.95

JMR 5 1/4" DISK DRIVE ENCLOSURES

Complete with power supply, switch, power cord, fuseholder and connectors

- DDE-1FH (Houses 1 full-ht. 5 1/4" floppy drive) \$ 69.95
- DDE-2HH (Houses 2 half-ht. 5 1/4" floppy drives - vertical) \$ 79.95
- HDDE-1FH (Houses 1 hard drive) \$199.95

General Application Keyboards

Mitsumi 54-Key Unencoded Keyboard

- SPST keyswitches - 20 pin ribbon cable connection
- Low profile keys - Features: cursor controls, control, caps (lock), function, enter and shift keys - Color (keycaps): grey - Weight: 1 lb. - Pinout incl. - Size: 13 1/2" x 4 1/4" W x 3/4" H

KB54 \$9.95

74-Key ASCII Cherry Keyboard

7-bit parallel ASCII - Full Upper Case, Full Lower Case except l, m, n, o and p - Cursor keypad - SPST mechanical keyswitches - 26-pin header connector - Color, white - Size: 18 1/2" x 6 1/4" W x 1 1/4" H - Spec included

KB8201 (1500 available) \$14.95

UV-EPROM ERASER

Erases all EPROMs. Erases up to 8 chips within 21 minutes (1 chip in 15 minutes). Maintains constant exposure distance of one inch. Special conductive foam liner eliminates static build-up. Built-in safety lock to prevent UV exposure. Compact - only 9.00" x 3.70" W x 2.60" H. Complete with holding tray for 8 chips.

DE-4 UV-EPROM Eraser \$74.95
UVS-11EL Replacement Bulb \$17.95

\$20 Minimum Order - U.S. Funds Only
 Shipping: Add 5% plus \$1.50 Insurance

California Residents: Add 6% or 6 1/2% Sales Tax

Spec. Sheets - 30¢ each
 Prices Subject to Change

Send stamped, self-addressed envelope to receive a Quarterly Sales Flyer - FREE!



Send \$1.00 Postage for a FREE 1986 JAMECO CATALOG

1355 SHOREWAY ROAD, BELMONT, CA 94002 • PHONE ORDERS WELCOME 415-592-8097 Telex: 176043

Radio Shack Parts Place™

THE BUILDER'S STORE! OVER 1000 COMPONENTS IN STOCK!

Just a Sample of Our Unique Electronics

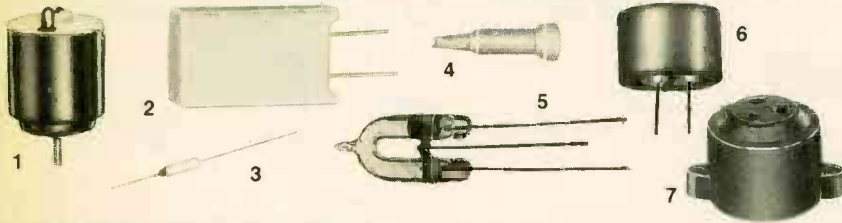

(1) **DC Hobby Motor.** Just right for model-making, solar and robotics experiments, or rainy day fun for the kids. Requires 1.5 to 3 VDC. #273-223 ... 79¢
 (2) **Gas Discharge Tube.** Fast-response transient protector for 120 VAC circuits. For use when repetitive surges are expected. #270-811 ... 2.49
 (3) **Replacement Thermal Fuses.** Used as a safety protection in many AC-operated coffee-makers and heating-type appliances. 240 VAC, 10 amps max.

Breaks Circuit at	Cat. No.	Each
139°C	270-1320	.79
226°C	270-1321	.79

(4) **IC Test Probe Adapter.** Fits over positive test lead to prevent accidental pin-to-pin shorting. 270-335 ... 99¢
 (5) **Xenon Flash Tube.** For replacement or projects. 100,000-flash life. With specs. #272-1145 ... 2.99
 (6) **PC Board-Mount Electret Mike Element.** Wide 20 to 15 kHz response. Requires 2-10 VDC. #270-090 ... 99¢
 (7) **Two-Tone Piezo Buzzer.** Super-loud 100 dB output. Use for security, power failure alerters and more. Requires 8 to 16 VDC. #273-070 ... 8.95

We Can Replace Almost Any IC or Semiconductor

New!

SPECIAL ORDER HOTLINE

Over 200,000 Substitutions!



No Minimum Order ■ No Postage Charge

If the device you need is not part of our regular stock, we'll check our new in-store substitution guide and special-order a replacement from our warehouse. Your order will be sent ASAP to your local Radio Shack store and we'll notify you when it arrives. We also offer this convenient service on selected tubes, crystals, phono cartridges and styli. Come in today for details!

Speech Synthesis ICs



Note: ICs are supplied with data and circuit examples. All required extra parts are available through Radio Shack.

SPO256-AL2 Speech Synthesis IC. This remarkable 28-pin MOS LSI device uses a built-in program to synthesize natural sounding speech. #276-1784 ... 12.95
CTS256-AL2 Text-to-Speech IC. This 40-pin device translates standard ASCII characters into control data for the synthesizer above. #276-1786 ... 16.95

4000-Series CMOS ICs

With Pin-Out And Specs

Low As **99¢**

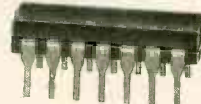

Type	Description	Cat. No.	Each
4001	Quad NOR Gate	276-2401	.99
4011	Quad NAND Gate	276-2411	.99
4013	Dual Flip Flop	276-2413	1.19
4017	Decade Counter	276-2417	1.49
4049	Hex Buffer	276-2449	1.19
4066	Quad Switch	276-2466	1.19

Ceramic Disc Capacitors



■ Hi-Q Design ■ Moistureproof Low As **39¢** Pkg. of 2

pF	Cat. No.	Pkg. of 2	µF	Cat. No.	Pkg. of 2
4.7	272-120 ¹	.39	.001	272-126*	.49
47	272-121 ¹	.39	.0047	272-130*	.49
100	272-123 ¹	.39	.01	272-131*	.59
220	272-124 ¹	.49	.047	272-134 ¹	.59
470	272-125 ¹	.49	.1	272-135 ¹	.59

¹ = Rated 500 WVDC

* = Rated 500 WVDC

Not Your Usual LEDs!



(8) **XC-5491 Tri-Color LED.** Great for status or polarity indicator. Glows red on DC, green on reverse DC, yellow on AC. T-1³/₄ size. #276-035 ... 1.29
 (9) **COX21 Blinking LED.** Combines a MOS integrated circuit driver and a red LED. T-1³/₄ size. Can drive several LEDs in series. #276-036 ... 1.59

64K Dynamic RAM

Highest Quality

Only **3⁹⁵**



4164. Manufacturer's prime memory chip with 150 ns access. Now's the time to upgrade your computer. Why gamble with (and wait for) a mail-order bargain? #276-2506 ... 3.95

Compact SPST Reed Relays

1⁴⁹ Each



Ideal for fast-reaction switching. Pins for PC mounting. Contacts: 1 amp at 125 VAC. Low-current coils.

Relay	Cat. No.	Each
5 VDC Coil	275-232	1.49
12 VDC Coil	275-233	1.49

Multitester Sale!

Super Saver!

Cut \$18⁰⁷

Reg. 39.95 **21⁸⁸**

- Easy-to-Read 4¹/_{4"} Mirrored Scale
- Range-Doubler for Extra Resolution



Accuracy, ease of use and famous Micronta® quality at an incredible 45% off! Features convenient single-knob function selection, 50k ohms-per-volt DC sensitivity, fuse and overload protection. Measures to 1000 volts AC and DC, DC current to 10 amps, 0 to 20 meg resistance, -20 to +62 dB. 6¹/₁₆ x 4⁷/₈ x 2¹/_{2"}. With leads, probes, manual. Batteries extra. #22-204

They Goofed, You Gain!

SPECIAL PURCHASES!

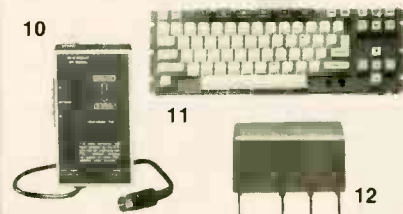

(10) **Prewired TV RF Modulator.** Use TV to monitor computers, satellite receivers, even build a custom datacom system (see 9/85 issue Modern Electronics, p. 53). #277-1015 ... 4.95
 (11) **Computer Keyboard.** Very high-quality full-stroke matrix-output board with standard "QWERTY" layout and total of 75 keys. With data. #277-1020 ... 5.95
 (12) **5 VDC DPDT DIP Relay.** Subminiature potted type fits 16-pin DIP socket. Contacts rated 2 amps at 120 VAC. #275-244 ... 1.99

Boards for Interface Projects

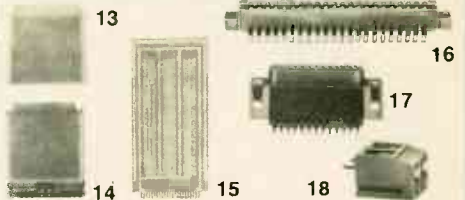

(13) **Two-Bus Plug-In Board.** 4¹/₂ x 4" with predrilled DIP pattern. Fits 44-pin socket. #276-152 ... 2.99
3-Voltage Source Plug-In Board. #276-154 ... 2.99
 (14) **Plug-In Board With RS-232 Ports.** Fits 44-position socket, accepts two RS-232 connectors (below). 4⁵/₁₆ x 5⁵/_{16"}, two buses, predrilled DIP pattern. #276-187 ... 3.99
 (15) **Jumbo Two-Bus Plug-In Board.** 4¹/₂ x 9⁹/_{16"}. Fits 44-position socket. Accepts up to 24 16-pin DIP sockets with ample room for discrete components. #276-190 ... 5.95
Jumbo One-Bus Plug-In Board. #276-191 ... 5.95
 (16) **44-Position Card-Edge Socket.** #276-1551 ... 2.99
 (17) **Sub-D 25-Right-Angle Connector.** #276-1521 ... 3.29
 (18) **Wire Terminals.** Set of 4. Mount on board, secure two wires. Clever stackable design. #276-1388 ... 4/1.99

Over 1000 items in stock: Binding posts, Books, Breadboards, Buzzers, Capacitors, Chokes, Clips, Connectors, Fuses, Hardware, ICs, Jacks, Knobs, Lamps, Multitesters, PC Boards, Plugs, Rectifiers, Relays, Resistors, Switches, Tools, Transformers, Transistors, Wire, Zener Diodes, and more!

Radio Shack®
A DIVISION OF TANDY CORPORATION

Prices apply at participating Radio Shack stores and dealers

RADIO-ELECTRONICS

★ QUALITY PARTS ★ DISCOUNT PRICES ★ FAST SHIPPING!

ALL ELECTRONICS CORP.

SEND FOR
FREE
NEW 1986 CATALOG...
48 PAGES!

SOLID STATE BUZZER



Star #SMB-06L
6 vdc
TTL compatible.
\$1.00 each
10 for \$9.00

2K 10 TURN
MULTI-TURN POT
SPECTROL
#MOD 534-7161
\$5.00 EACH

SLIM LINE COOLING FAN



Etr # \$99KM182 low noise fan. Measures 3 3/4" square x 1" deep. 21 cfm, 23 db, 1700 rpm
SPECIAL PRICE ... \$12.50 each

SOUND AND VIDEO MODULATOR FOR T.I. COMPUTER



T.I. # UM1381-1. Designed for use with T.I. computers. Can be used with video sources. Built-in A/B switch, Channel 3 or 4 selection switch. Operate on 12 vdc. Hook-up diagram included.
\$10.00 EACH

± 12 Vdc or 24Vdc POWER SUPPLY

DELTRON MODEL QD12/15-1.7 Dual plus and minus 12Vdc open frame power supply. Can be used as 24Vdc @ 1.5 amp. INPUT: either 115 Vac or 230 Vac Fully regulated computer grade supply. 7" x 4 1/2" x 2 3/4"
\$12.50 each 10 for \$110.00

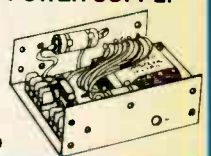

EDGE CONNECTORS

ALL ARE 1.56" SPACING.

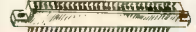

- 22/44 EDGE CONNECTOR
PC. style \$2.00 each
10 for \$18.00
- 22/44 EDGE CONNECTOR
solder lug style \$2.50 each
- 28/56 EDGE CONNECTOR
PC. style \$2.50 each
10 for \$22.00
- 36/72 EDGE CONNECTOR
PC. style \$3.00 each
- 43/86 EDGE CONNECTOR
PC. style \$4.50 each

TRANSISTORS

- 2N706 4 for \$1.00
- 2N2222A 3 for \$1.00
- PN2222A 4 for \$1.00
- 2N2904 3 for \$1.00
- 2N2904 4 for \$1.00
- 2N2905 3 for \$1.00
- 2N2905 4 for \$1.00
- MJ2955 \$1.50
- 2N3055 \$1.00
- PMD 10K40 \$1.00
- TIP 121 75¢
- TIP 125 75¢

SPECIAL PRICE TRANSISTOR

PN3569 TO-92 N.P.N. plastic transistor
100 for \$8.00
1000 for \$60.00
LARGE QUANTITIES AVAILABLE

TRANSFORMERS

- 120 volt primaries
- 5.6 volts @ 750 ma. \$3.00
- 6 volts @ 150 ma. \$1.25
- 12 v.c.t. @ 200 ma. \$2.00
- 18 volts @ 650 ma. \$3.50
- 18 volts @ 1 amp \$4.50
- 24 v.c.t. @ 200 ma. \$2.50
- 24 v.c.t. @ 400 ma. \$3.00
- 28 v.c.t. @ 15 amps \$20.00
- 30 v.c.t. @ 2 amps \$5.00

WALL TRANSFORMERS

- all plug directly into 120 vac outlet
- 4 VDC @ 70 ma. \$2.00
- 6 VAC @ 500 ma. \$3.50
- 6 VDC @ 750 ma. \$3.50
- 9 VDC @ 500 ma. \$6.50
- 12.5 VAC @ 265 ma. \$5.00
- 24 v.c.t. @ 250 ma. \$3.00
- MULTI-VOLTAGE @ 500 ma. \$3.00
- 3, 4, 6, 7, 9 or 12 VDC \$7.50

MINI-BOX

Pomona #2104
Heavy-duty black phenolic project box with cover and screws. 2 1/4" x 1 1/2" x 1 1/2"
\$1.00 EACH

FUSES

- 3AG (AGC) SIZE
1, 1 1/2, 2, 2 1/2, 3, 4, 5, 6 AMP
- GMA SIZE
1, 2, 3, 4, 5 AMP
- all of any ONE amperage 75¢

SPECIALS OF THE MONTH

ALL 1/4 WATT RESISTORS
1000 pcs of one value \$7.50

ALL 1/2 WATT RESISTORS
1000 pcs of one value \$9.50

1 AMP 50 VOLT DIODES
IN 4001 TAPE AND REEL
100 for \$4.50
1000 for \$30.00

D STYLE CONNECTORS
DB25 PLUG 10 for \$11.00
100 for \$100.00
DB25 SOCKET 10 for \$12.50
100 for \$110.00

SOLDER TAIL I.C. SOCKETS
24 PIN 10 for \$2.50
100 for \$22.00
1000 for \$200.00

CASSETTE MIKE

Dynamic cassette mike with 3.5mm plug and on/off switch.
\$1.50 EACH 10 FOR \$13.50

TWIST-LOCK CONNECTOR

Same as Switchcraft #12CL5M.
5 conductor in-line plug and chassis mount jack. Twist-lock style.
\$2.50/SET

TI SWITCHING POWER SUPPLY

Compact, well-regulated switching power supply designed to power Texas Instruments computer equipment.
INPUT: 14 - 25 vac @ 1 amp
OUTPUT: + 12 vdc @ 350 ma.
- 5 vdc @ 1.2 amp
- 5 vdc @ 200 ma.
SIZE: 4 3/4" x 4 1/4" x 1 1/4" high \$5.00 each

13.8 VDC REGULATED POWER SUPPLY

These are solid state, fully regulated 13.8 vdc power supplies. Both feature 100% solid state construction, fuse protection, and L.E.D. power indicator. U.L. listed.
2 amp constant, 4 amp surge \$18.00 each
3 amp constant, 5 amp surge \$25.00 each

D.C. CONVERTER

Designed to provide a steady ± 5 vdc @ 240 ma. from a battery supply of 3.5 to 6.25 volts.
2 1/16" x 1 1/16" x 1 1/16"
\$1.50 each

8" P.A. SPEAKER

C.T.S. Model 8B3079 \$5.00 each
8 ohms coil
3.0 oz. ferrite magnet
Typical response range: 100 - 10,000 Hz
Power rating 15 watts max.
Drilled to mount line matching transformers.
CASE OF 8 SPEAKERS \$32.00

LINE CORDS

TWO WIRE
6' 18/2 SPT-1 flat 3 for \$1.00
6' 18/2 SPT-2 flat 3 for \$1.00

6' 16/2 SJT round \$1.25 each

THREE WIRE
6' 18/3 flat \$1.50 each
8' 18/3 round \$2.00 each
8' 16/3 round \$4.00 each

COMPUTER GRADE CAPACITORS

- 2,000 mfd. 200 VDC \$2.00
1 1/4" DIA. x 5" HIGH
- 3,600 mfd. 40 VDC \$1.00
1 1/8" DIA. x 3 3/4" HIGH
- 6,400 mfd. 60 VDC \$2.50
1 1/8" DIA. x 4 1/4" HIGH
- 9,700 mfd. 50 VDC \$3.00
1 3/8" DIA. x 4 1/2" HIGH
- 31,000 mfd. 15 VDC \$2.50
1 1/4" DIA. x 4" HIGH
- 72,000 mfd. 15 VDC \$3.50
2" DIA. x 4 3/4" HIGH
- 185,000 mfd. 6 VDC \$1.50
2 1/2" DIA. x 4 1/2" HIGH

4PDT RELAY

14 pin KH style... 3 amp contacts... USED but fully tested... \$1.70 each
Specify coil voltage desired
Either 24 vdc or 120 vac
LARGE QUANTITIES AVAILABLE
SOCKETS FOR KH RELAY 75¢ each

RECHARGEABLE NI-CAD BATTERIES

- AAA SIZE 1.25V 500MAH \$1.85
- AA SIZE 1.25V 500MAH \$1.85
- AA with solder tab \$2.00
- C SIZE 1.2V 1200MAH \$3.50
- D SIZE 1.2V 1200MAH \$3.50

UNIVERSAL CHARGER

Will charge 4-AA, C, D, or AAA ni-cads or one 9 volt ni-cad at one time...
\$11.00 per charger

SPECIAL PRICE DUAL L.E.D. DISPLAYS

.560 high, 7 segment L.E.D. read-outs. Mount in 24 pin DIP sockets...
MAN-6640 orange, c.c. 75¢ each
FND-5148 red, c.c. 75¢ each
DL-527 red, c.c. 75¢ each

3 1/2" SPEAKER

8 ohm impedance, Full range speaker. 8 oz magnet 4" diagonal mounting centers.
\$2.50 each 10 for \$20.00

SPRING LEVER TERMINALS

Two color coded terminals on a sturdy 2 3/4" x 3 3/4" bakelite plate. Great for speaker enclosures or power supplies.
75¢ EACH 10 for \$6.00

MINIATURE TOGGLE SWITCHES

- S.P.D.T. (on-on) \$1.00 each
PC. style non-threaded bushing. 75¢ each 10 for \$7.00
- S.P.D.T. (on-on) \$1.00 each
Solder lug terminals. \$1.00 each 10 for \$9.00
100 for \$86.00
- S.P.D.T. (on-off-on) \$1.00 each
Solder lug terminals. \$1.00 each 10 for \$9.00
100 for \$80.00
- S.P.D.T. (on-off-on) \$1.00 each
PC. lugs threaded bushing. \$1.00 each 10 for \$9.00
100 for \$80.00
- D.P.D.T. (on-on) \$2.00 each
Solder lug terminals. \$2.00 each 10 for \$19.00
100 for \$180.00

STANDARD JUMBO DIFFUSED T 1 1/2

- RED 10 for \$1.50
100 for \$13.00
- GREEN 10 for \$2.00
100 for \$17.00
- YELLOW 10 for \$2.00
100 for \$17.00

FLASHER LED

5 volt operation red jumbo T 1 1/2 size \$1.00 each

BI-POLAR jumbo T 1 1/2 size

2 for \$1.70

LED HOLDERS

Two piece holder for jumbo LED 10 for 85¢ 100 for \$5.00

CASSETTE MECHANISM

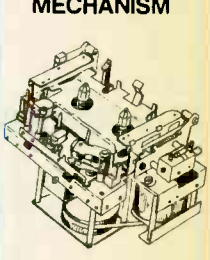

New stereo cassette mechanism includes record/playback and erase heads. 2-12VDC motors drive belts, pulleys, 3-12VDC solenoids, pinch wheels and other mechanical parts. These parts, used on other current model decks, would cost several times our selling price if purchased separately. Build your own audio or data recorder or use for spare parts.
5 1/4" x 3 1/2" x 3 1/8"
\$7.50 EACH 2 FOR \$12.50

D.P.S.T. LIGHTED ROCKER SWITCH

115 vac lighted rocker, snap mounts in 3/8" x 1 1/4" hole. Orange lens. 16 amp contact.
\$1.50

MINI-PUSH BUTTON

S.P.S.T. momentary normally open 1/4" bushing. Red button.
35¢ each 10 for \$3.00

SNAP ACTION SWITCH

Cherry elect. #E-21, N.O. or N.C. 0.1A contacts. Suitable for alarms and other low energy circuits.
1 1/2" lever.
45¢ EACH 10 FOR \$4.20

ROTARY ACTION MICRO

OMRON #C-5G3-C41
Clockwise action micro used in coin operated mechanisms and low torque operations.
RATED: 5 amps @ 125 Vac.
\$1.25 each 10 for \$11.00
LARGE QUANTITIES AVAILABLE

ALL ELECTRONICS CORP.
LOS ANGELES, CA STORE
905 S. Vermont Ave
213 380-8000
VAN NUYS, CA STORE
6228 Sepulveda Blvd.
818 997-1806

MAIL ORDERS TO:
P.O. BOX 20406
Los Angeles, CA 90006
TWX - 51010163 ALL ELECTRONIC
EASYLINK MBX - 62887748



TOLL FREE ORDERS ONLY
1-800-826-5432
(ORDER ONLY)
(IN CALIFORNIA 1-800-258-6666)
ALASKA, HAWAII,
OR INFORMATION
(213) 380-8000 NO C.O.D.!

QUANTITIES LIMITED
MINIMUM ORDER \$10.00
USA: \$3.00 SHIPPING
FOREIGN ORDERS
INCLUDING SUFFICIENT
SHIPPING
CALIF RES. ADD 6 1/2%

MARCH 1986

BUILD A COMPLETE XT SYSTEM—\$698

STATIC RAMS

2101	256x4	(450ns)	1.95
5101	256x4	(450ns)(CMOS)	3.95
2102L-4	1024x1	(450ns)(LP)	1.45
2102L-2	1024x1	(250ns)(LP)	2.99
2112	256x4	(450ns)	.99
2114	1024x4	(450ns)	1.09
2114L-4	1024x4	(450ns)(LP)	1.49
2114L-2	1024x4	(200ns)(LP)	1.95
TMS4044-4	1024x4	(150ns)(LP)	1.95
TMM2016-150	2048x8	(150ns)	1.45
TMM2016-100	2048x8	(100ns)	1.95
HM6116-4	2048x8	(200ns)(CMOS)	1.39
HM6116-3	2048x8	(150ns)(CMOS)	1.49
HM6116LP-4	2048x8	(200ns)(CMOS)(LP)	1.49
HM6116LP-3	2048x8	(150ns)(CMOS)(LP)	1.59
HM6264P-2	2048x8	(120ns)(CMOS)(LP)	2.95
HM6264P-15	8192x8	(150ns)(CMOS)	3.99
HM6264LP-15	8192x8	(150ns)(CMOS)(LP)	3.95
HM6264LP-12	8192x8	(120ns)(CMOS)(LP)	4.49

LP—Low power

DYNAMIC RAMS

4116-250	16384x1	(250ns)	.49
4116-200	16384x1	(200ns)	.69
4116-150	16384x1	(150ns)	.89
4116-120	16384x1	(120ns)	1.49
MK4332	32768x1	(200ns)	6.95
4164-200	65536x1	(200ns)(5V)	.95
4164-150	65536x1	(150ns)(5V)	.99
4164-120	65536x1	(120ns)(5V)	1.95
MCM6665	65536x1	(200ns)(5V)	1.95
TMS4164	65536x1	(150ns)(5V)	1.95
4164-REFRESH	65536x1	(150ns)(5V)(REFRESH)	2.95
TMS4416	16384x4	(150ns)(5V)	4.95
41128-150	131072x1	(150ns)(5V)	5.95
41256-200	262144x1	(200ns)(5V)	2.95
41256-150	262144x1	(150ns)(5V)	2.95

5V—Single 5 Volt Supply

REFRESH—Pin 1 Refresh

★★★HIGH-TECH★★★

NEC V20 UPD70108 \$1495

REPLACES 8088 TO SPEED UP IBM PC 10-40%

- * HIGH-SPEED ADDRESS CALCULATION IN HARDWARE
- * PIN COMPATIBLE WITH 8088
- * SUPERSET OF 8086/8088 INSTRUCTION SET
- * LOW POWER CMOS

8 MHZ V20 UPD70108-8 \$24.95
8 MHZ V30 UPD70116-8 \$26.95

★★★SPOTLIGHT★★★

ORDER TOLL FREE
800-538-5000
800-662-6279 (CA)



EPROMS

2708	1024x8	(450ns)	3.95
2716-6	2048x8	(650ns)	2.29
2716	2048x8	(450ns)(5V)	2.29
2716-1	2048x8	(200ns)(5V)	2.75
TMS2532	4096x8	(450ns)(5V)	3.95
2732	4096x8	(450ns)(5V)	2.45
2732A	4096x8	(250ns)(5V)(21V PGM)	2.75
2732A-2	4096x8	(200ns)(5V)(21V PGM)	3.95
27C64	8192x8	(250ns)(5V)(CMOS)	5.95
2764	8192x8	(450ns)(5V)	2.45
2764-250	8192x8	(250ns)(5V)	2.85
2764-200	8192x8	(200ns)(5V)	3.49
TMS2564	8192x8	(450ns)(5V)	8.95
MCM68766	8192x8	(350ns)(5V)(24 PIN)	17.95
27128	16384x8	(250ns)(5V)	2.79
27C256	32768x8	(250ns)(5V)(CMOS)	12.95
27256	32768x8	(250ns)(5V)	7.49

SPECTRONICS CORPORATION EPROM ERASERS



Model	Timer	Capacity Chip	Intensity (uW/Cm ²)	Unit Price
PE-14	NO	9	8,000	\$83.00
PE-14T	YES	9	8,000	\$119.00
PE-24T	YES	12	9,600	\$175.00

8000

8035	1.49
8039	1.95
8080	2.95
8085	2.49
8087-2	139.95
8087	109.00
8088	6.95
8088-2	9.95
8155	2.49
8155-2	3.95
8748	19.95
8755	19.95
80286	129.95
80287	185.00

8200

8203	29.95
8205	3.29
8212	1.49
8216	1.49
8224	2.25
8237	5.49
8237-5	5.49
8250	6.95
8251	1.89
8251A	1.89
8253	1.89
8253-5	1.95
8255	1.69
8255-5	1.89
8259	1.95
8259-5	2.29
8272	4.95
8279	2.49
8279-5	2.95
8282	3.95
8284	2.95
8286	3.95
8288	4.95

Z-80

Z80-CPU 2.5 MHz 1.69
4.0 MHZ
Z80A-CPU 1.79
Z80A-CTC 1.89
Z80A-DART 5.95
Z80A-DMA 5.95
Z80A-PIO 1.89
Z80A-SIO/0 5.95
Z80A-SIO/1 5.95
Z80A-SIO/2 5.95

6.0 MHZ

Z80B-CTC 3.75
Z80B-CPU 4.25
Z80B-PIO 4.25
Z80B-DART 14.95
Z80B-SIO/0 12.95
Z80B-SIO/1 12.95
Z80B-SIO/2 12.95
Z8671 ZILOG 19.95

6500

1.0 MHZ	
6502	2.79
65C02(CMOS)	12.95
6507	9.95
6520	1.95
6522	4.95
6526	26.95
6532	6.95
6545	6.95
6551	5.95
6561	19.95
6581	34.95

2.0 MHZ

6502A	2.95
6520A	2.95
6522A	5.95
6532A	11.95
6545A	7.95
6551A	6.95

3.0 MHZ

6502B	6.95
-------	------

6800

1.0 MHZ	
6800	1.95
6802	4.95
6803	9.95
6809	5.95
6810	5.95
6810	1.95
6820	2.95
6821	1.95
6824	6.95
6843	19.95
6844	12.95
6845	4.95
6847	11.95
6850	1.95
6883	22.95

2.0 MHZ

68800	4.95
68802	5.95
68809	6.95
68809	6.45
68821	3.50
68845	6.75
68850	3.95
68854	7.95

CLOCK CIRCUITS

MM5369	1.95
MM5369-EST	1.95
MM58167	12.95
MM58174	11.95
MSM5832	2.95

CRT CONTROLLERS

6845	4.95
68B45	8.95
6847	11.95
HD46505SP	6.95
MC1372	2.95
8275	26.95
7220	19.95
CR15027	12.95
CR15037	9.95
TMS918A	19.95

DISK CONTROLLERS

1771	4.95
1791	9.95
1793	9.95
1795	12.95
1797	12.95
2791	19.95
2793	19.95
2797	29.95
6845	19.95
8272	4.95
UPD765	4.95
MB8876	12.95
MB8877	12.95
1691	6.95
2143	6.95

BIT RATE GENERATORS

MC14411	9.95
BR1941	4.95
4702	9.95
COM8116	8.95
MM5307	4.95

UARTS

AY5-1013	3.95
AY3-1015	4.95
TR1602	3.95
2651	4.95
IM6402	6.95
IM6403	9.95
INS8250	6.95

SOUND CHIPS

76477	3.95
76489	8.95
MC3487	2.95
SSI-263	39.95
AY3-8910	12.95
AY3-8912	12.95
SP1000	39.00

CRYSTALS

32,768 KHz	.95
1.0 MHZ	2.95
1.8432	2.95
2.0	1.95
2.097152	1.95
2.4576	1.95
3.2768	1.95
3.579545	1.95
4.0	1.95
4.032	1.95
5.0	1.95
5.0688	1.95
6.0	1.95
6.144	1.95
6.536	1.95
8.0	1.95
10.0	1.95
10.738635	1.95
12.0	1.95
14.31818	1.95
15.0	1.95
16.0	1.95
17.430	1.95
18.432	1.95
18.432	1.95
18.432	1.95
20.0	1.95
22.1184	1.95
24.0	1.95
32.0	1.95

CRYSTAL OSCILLATORS

1.0MHz	5.95
1.8432	5.95
2.0	5.95
2.4576	5.95
2.5	4.95
4.0	4.95
5.0688	4.95
6.0	4.95
6.144	4.95
8.0	4.95
10.0	4.95
12.0	4.95
12.480	4.95
15.0	4.95
16.0	4.95
18.432	4.95
20.0	4.95
24.0	4.95

MISC.

TMS99531	9.95
TMS99532	19.95
ULN2003	.79
3242	7.95
3341	4.95
MC3470	1.95
MC3480	8.95
MC3487	2.95
11C90	13.95
2513-001 UP	6.95
AY5-2376	11.95
AY5-3600 PRO	11.95

74LS00

74LS00	.16
74LS01	.18
74LS02	.17
74LS03	.18
74LS04	.16
74LS05	.18
74LS08	.18
74LS09	.18
74LS10	.16
74LS11	.22
74LS12	.22
74LS13	.26
74LS14	.39
74LS15	.26
74LS20	.17
74LS21	.22
74LS22	.22
74LS27	.22
74LS28	.26
74LS30	.17
74LS32	.18
74LS33	.28
74LS37	.26
74LS38	.26
74LS42	.39
74LS43	.39
74LS48	.69
74LS51	.17
74LS73	.29
74LS74	.24
74LS75	.29
74LS76	.29
74LS77	.49
74LS85	.49
74LS86	.22
74LS90	.39
74LS92	.49
74LS93	.39
74LS95	.49
74LS107	.34
74LS109	.36
74LS112	.29
74LS122	.45
74LS123	.49
74LS124	2.75
74LS125	.39
74LS126	.39
74LS132	.39
74LS133	.49
74LS136	.39
74LS138	.39
74LS139	.39
74LS145	.99
74LS147	.99
74LS148	.99
74LS151	.39
74LS153	.39
74LS154	1.49
74LS155	.59
74LS156	.49
74LS157	.35
81LS38	1.49
74LS160	.29
74LS161	.39
74LS162	.49
74LS163	.39
74LS164	.49

74LS165

74LS165	.65
74LS166	.95
74LS169	.95
74LS173	.49
74LS174	.39
74LS175	.39
74LS191	.49
74LS192	.69
74LS193	.69
74LS194	.69
74LS195	.69
74LS196	.59
74LS197	.59
74LS221	.59
74LS240	.69
74LS241	.69
74LS242	.69
74LS243	.69
7	

PARTIAL LISTING ONLY — CALL FOR A FREE CATALOG

CMOS		
4001	.19	14419 4.95
4011	.19	14433 14.95
4012	.25	4503 .49
4013	.35	4511 .69
4015	.29	4516 .79
4016	.29	4518 .85
4017	.49	4522 .79
4018	.69	4526 .79
4020	.59	4527 1.95
4021	.69	4528 .79
4024	.49	4529 2.95
4025	.25	4532 1.95
4027	.39	4538 .95
4028	.65	4541 1.29
4035	.69	4553 5.79
4040	.69	4585 .75
4041	.75	4702 12.95
4042	.59	74C00 .29
4043	.85	74C14 .59
4044	.69	74C74 .59
4045	1.98	74C83 1.95
4046	.69	74C85 1.49
4047	.69	74C95 .99
4049	.29	74C150 5.75
4050	.29	74C151 2.25
4051	.69	74C161 .99
4052	.69	74C163 .99
4053	.69	74C164 1.39
4056	2.19	74C192 1.49
4060	.69	74C193 1.49
4066	.29	74C221 1.75
4069	.19	74C240 1.89
4076	.59	74C244 1.89
4077	.29	74C374 1.99
4081	.22	74C905 10.95
4085	.79	74C911 8.95
4086	.89	74C917 8.95
4093	.49	74C922 4.49
4094	2.49	74C923 4.95
14411	9.95	74C926 7.95
14412	6.95	80C97 .95

7400/9000		
7400	.19	74147 2.49
7402	.19	74148 1.20
7404	.19	74150 1.35
7406	.29	74151 .55
7407	.29	74153 .55
7408	.24	74154 1.49
7410	.19	74155 .75
7411	.25	74157 .55
7414	.49	74159 1.65
7416	.25	74161 .69
7417	.25	74163 .69
7420	.19	74164 .85
7423	.29	74165 .85
7430	.19	74166 1.00
7432	.29	74175 .89
7438	.29	74177 .75
7442	.49	74178 1.15
7445	.69	74181 2.25
7447	.89	74182 .75
7470	.35	74184 2.00
7473	.34	74191 1.15
7474	.33	74192 .79
7475	.45	74194 .85
7476	.35	74196 .79
7483	.50	74197 .75
7485	.59	74199 1.35
7486	.35	74221 1.35
7489	2.15	74246 1.35
7490	.39	74247 1.25
7492	.50	74248 1.85
7493	.35	74249 1.95
7495	.55	74251 .75
7497	2.75	74265 1.35
74100	2.29	74273 1.95
74121	.29	74278 3.11
74123	.49	74367 .65
74125	.45	74368 .65
74141	.65	9368 3.95
74143	5.95	9602 1.50
74144	2.95	9637 2.95
74145	.60	96502 1.95

74S00		
74S00	.29	74S163 1.29
74S02	.29	74S168 3.95
74S03	.29	74S174 .79
74S04	.29	74S175 .79
74S05	.29	74S188 1.95
74S08	.35	74S189 1.95
74S10	.29	74S195 1.49
74S15	.35	74S196 1.49
74S30	.29	74S197 1.49
74S32	.35	74S225 3.99
74S37	.69	74S240 1.49
74S38	.69	74S241 1.49
74S74	.49	74S244 1.49
74S85	.95	74S257 .79
74S86	.35	74S253 .79
74S112	.50	74S258 .95
74S124	2.75	74S280 1.95
74S138	.79	74S287 1.69
74S140	.55	74S288 1.69
74S151	.79	74S299 2.95
74S153	.79	74S373 1.69
74S157	.79	74S374 1.69
74S158	.95	74S471 4.95
74S161	1.29	74S571 2.95

VOLTAGE REGULATORS		
TO-220 CASE		
7805T	.49	7905T .59
7808T	.49	7908T .59
7812T	.49	7912T .59
7815T	.49	7915T .59
TO-3 CASE		
7805K	1.39	7905K 1.49
7812K	1.39	7912K 1.49
TO-92 CASE		
78L05	.49	79L05 .69
78L12	.49	79L12 .69
OTHER VOLTAGE REGS		
LM323K 5V 3A	TO-3	4.79
LM338K A ₄ 5A	TO-3	3.95
78H05K 5V 5A	TO-3	7.95
78H12K 12V 5A	TO-3	8.95
78P05K 5V 10A	TO-3	14.95

LINEAR		
TL066	.99	LM733 .98
TL071	.69	LM741 .29
TL072	1.09	LM747 .69
TL074	1.95	LM748 .59
TL081	.59	MC1300 1.69
TL082	.99	MC1350 1.19
TL084	1.49	MC1372 6.95
LM301	.34	LM1414 1.59
LM309K	1.25	LM1458 .49
LM311	.59	LM1488 .49
LM311H	.89	LM1489 .49
LM317K	3.49	LM1496 .85
LM317T	.95	LM1812 8.25
LM318	1.49	LM1889 1.95
LM319	1.25	ULN2003 .79
LM320	see 7900	XR2206 3.75
LM322	1.65	XR2211 2.95
LM323K	4.79	XR2240 1.95
LM324	.49	MPQ2907 1.95
LM331	3.95	LM2517 1.95
LM334	1.19	CA3046 .89
LM335	1.40	CA3081 .99
LM336	1.75	CA3082 .99
LM337K	3.95	CA3086 .80
LM338K	3.95	CA3089 1.95
LM339	.59	CA3130E .99
LM340	see 7800	CA3146 1.29
LM350T	4.60	CA3160 1.19
LF353	.59	MC3470 1.95
LF356	.99	MC3480 8.95
LF357	.99	MC3487 2.95
LM358	.59	LM3900 .49
LM380	.89	LM3909 .98
LM383	1.95	LM3911 2.25
LM386	.89	LM3914 2.39
LM393	.45	MC4024 3.49
LM394H	4.60	MC4044 3.99
TL494	4.20	RC4136 1.25
TL497	3.25	RC4558 .69
NE555	.29	LM13600 1.49
NE556	.49	75107 1.49
NE558	1.29	75111 1.95
NE564	.95	75150 1.95
LM565	.95	75154 1.95
LM566	1.49	75188 1.25
LM567	.79	75189 1.25
NE570	2.95	75451 .39
NE590	2.50	75452 1.39
NE592	.98	75453 .39
LM710	.75	75477 1.99
LM723	.49	75492 .79
H-T0-5 CAN, K-T0-3, T-T0-220		

DATA ACQ INTERFACE		
ADC0800	15.55	8T26 1.29
ADC0804	3.49	8T28 1.29
ADC0809	4.49	8T95 .89
ADC0816	14.95	8T96 .89
ADC0817	9.95	8T97 .59
ADC0831	8.95	8T98 .89
DAC0800	4.49	DM8131 2.95
DAC0806	1.95	DP8304 2.29
DAC0808	2.95	DS8833 2.25
DAC1020	8.25	DS8835 1.99
DAC1022	5.95	DS8836 1.99
MC1408L8	2.95	DS8837 1.65

IC SOCKETS		
8 PIN ST	1-99	100
14 PIN ST	.13	.11
16 PIN ST	.17	.13
18 PIN ST	.20	.18
20 PIN ST	.29	.27
22 PIN ST	.30	.27
24 PIN ST	.30	.27
28 PIN ST	.40	.32
40 PIN ST	.49	.39
64 PIN ST	4.25	CALL
ST-SOLDER TAIL		
8 PIN WW	.59	.49
14 PIN WW	.69	.52
16 PIN WW	.69	.58
18 PIN WW	.99	.90
20 PIN WW	1.09	.98
22 PIN WW	1.39	1.28
24 PIN WW	1.49	1.35
28 PIN WW	1.69	1.49
40 PIN WW	1.99	1.80
WW-WIREWRAP		
16 PIN ZIF	4.95	CALL
24 PIN ZIF	5.95	CALL
28 PIN ZIF	6.95	CALL
40 PIN ZIF	9.95	CALL
ZIF-TEXT TOOL (ZERO INSERTION FORCE)		

EDGECARD CONNECTORS		
100 PIN ST	S-100	.125 3.95
100 PIN WW	S-100	.125 4.95
62 PIN ST	IBM PC	1.00 1.95
50 PIN ST	APPLE	.100 2.95
44 PIN ST	STD	.156 1.95
44 PIN WW	STD	.156 4.95

36 PIN CENTRONICS		
MALE		
IDCEN36	RIBBON CABLE	6.95
CEN36S	SOLDER CUP	4.95
IDCEN36PC	RT ANGLE PC MOUNT	4.95
FEMALE		
IDCEN36/F	RIBBON CABLE	7.95

INTERSIL		
ICL7106	9.95	
ICL7107	12.95	
ICL7660	2.95	
ICL8038	4.95	
ICM7207A	5.95	
ICM7208	15.95	

DESCRIPTION	ORDER BY	CONTACTS											
		8	14	16	18	20	22	24	28	40			
HIGH RELIABILITY TOOLED ST IC SOCKETS	AUGATxxST	.62	.79	.89	1.09	1.29	1.39	1.49	1.69	2.49			
HIGH RELIABILITY TOOLED WW IC SOCKETS	AUGATxxWW	1.30	1.80	2.10	2.40	2.50	2.90	3.15	3.70	5.40			
COMPONENT CARRIES (DIP HEADERS)	ICCxx	.49	.59	.69	.99	.99	.99	.99	1.09	1.49			
RIBBON CABLE DIP PLUGS (IDC)	IDPxx	---	.95	.95	---	---	---	---	1.75	---	2.95		

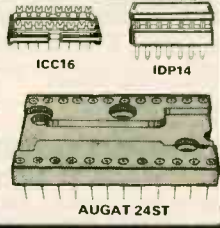

FOR ORDERING INSTRUCTIONS SEE D-SUBMINIATURE BELOW

D-SUBMINIATURE								
DESCRIPTION	ORDER BY	CONTACTS						
		9	15	19	25	37	50	
SOLDER CUP	MALE	DBxxP	.82	.90	1.25	1.25	1.83	3.48
	FEMALE	DBxxS	.95	1.15	1.50	1.50	2.35	4.32
RIGHT ANGLE PC SOLDER	MALE	DBxxPR	1.20	1.49	---	1.95	2.65	---
	FEMALE	DBxxSR	1.25	1.55	---	2.00	2.79	---
WIRE WRAP	MALE	DBxxPWW	1.69	2.56	---	3.89	5.60	---
	FEMALE	DBxxSww	2.76	4.27	---	6.84	9.95	---
IDC RIBBON CABLE	MALE	IDBxxP	2.70	2.95	---	3.98	5.70	---
	FEMALE	IDBxxS	2.92	3.20	---	4.33	6.76	---
HOODS	METAL	MHOODxx	1.25	1.25	1.30	1.30	---	---
	GREY	HOODxx	.65	.65	---	.65	.73	.95

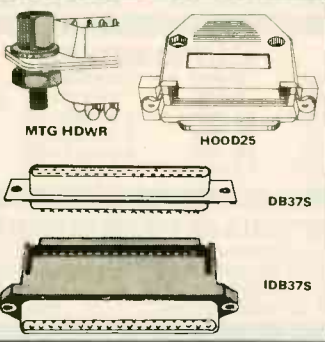

ORDERING INSTRUCTIONS: INSERT THE NUMBER OF CONTACTS IN THE POSITION MARKED "xx" OF THE "ORDER BY" PART NUMBER LISTED.

EXAMPLE: A 15 PIN RIGHT ANGLE MALE PC SOLDER WOULD BE DB15PR

MOUNTING HARDWARE \$1.00

IDC CONNECTORS							
DESCRIPTION	ORDER BY	CONTACTS					
		10	20	26	34	40	50
SOLDER HEADER	IDHxxS	.82	1.29	1.68	2.20	2.58	3.24
RIGHT ANGLE SOLDER HEADER	IDHxxSR	.85	1.35	1.76	2.31	2.72	3.39
WW HEADER	IDHxxW	1.86	2.98	3.84	4.50	5.28	6.63
RIGHT ANGLE WW HEADER	IDHxxWR	2.05	3.28	4.22	4.45	4.80	7.30
RIBBON HEADER SOCKET	IDSxx	.79	.99	1.39	1.59	1.99	2.25
RIBBON HEADER	IDMxx	---	5.50	6.25	7.30	7.50	8.50
RIBBON EDGE CARD	IDExx	1.75	2.25	2.65	2.75	3.80	3.95

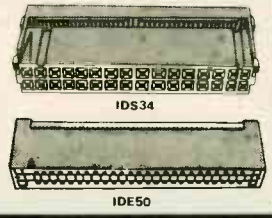

FOR ORDERING INSTRUCTIONS SEE D-SUBMINIATURE ABOVE

HARD TO FIND "SNAPABLE" HEADERS		
1x40	STRAIGHT LEAD	.99
1x40	RIGHT ANGLE	1.49
2x40	STRAIGHT LEAD	2.49
2x40	RIGHT ANGLE	2.99

SHORTING BLOCKS		
GOLD CONTACTS	SPACED AT .1" CENTERS	
5/\$1.00		

It was a pleasure to place an order with your people. I found the response pleasant and helpful and the answers prompt and correct. The delivery on my most recent order was fast, correct and well packed. I already had faith in the quality since my family has been using some of your products for several years with no problems.

Sincerely, J.D. Hattaway

CALL FOR VOLUME QUOTES

© COPYRIGHT 1985 JDR MICRODEVICES

CIRCLE 253 ON FREE INFORMATION CARD

BARGAIN HUNTERS CORNER DISK DRIVE SPECIALS

TEAC FD-54B 5 1/4" DS/DD \$85⁰⁰
1/2 HEIGHT, IBM COMPATIBLE DIRECT DRIVE

QUME QT-142 5 1/4" DS/DD \$69⁹⁵
1/2 HEIGHT, IBM COMPATIBLE BELT DRIVE

SHUGART SA-810 8" DS/DD \$99⁹⁵
1/2 HEIGHT DIRECT DRIVE CTM COMPATIBLE

TS-806 CABINET & POWER SUPPLY \$99⁹⁵
ONE TEAC FD-54B AND ROOM FOR A FULL OR 1/2
HEIGHT HARD DISK. A CLOSE-OUT SPECIAL FROM A
MAJOR MANUFACTURER (WE CAN'T SAY WHO),
PERFECT FOR THE HOBBYIST.

**HURRY — QUANTITIES ARE LIMITED!
SPECIALS END 2/28/86**

PAGE WIRE WRAP WIRE PRECUT ASSORTMENT IN ASSORTED COLORS \$27.50

100ea: 5.5", 6.0", 6.5", 7.0"
250ea: 2.5", 4.5", 5.0"
500ea: 3.0", 3.5", 4.0"

SPOOLS

100 feet \$4.30 250 feet \$7.25
500 feet \$13.25 1000 feet \$21.95

Please specify color:
Blue, Black, Yellow or Red

WIRE WRAP PROTOTYPE CARDS FR-4 EPOXY GLASS LAMINATE WITH GOLD-PLATED EDGE-CARD FINGERS



IBM-PR2

IBM

BOTH CARDS HAVE SILK SCREENED LEGENDS
AND INCLUDES MOUNTING BRACKET

IBM-PR1 WITH +5V AND GROUND PLANE \$27.95
IBM-PR2 AS ABOVE WITH DECODING LAYOUT \$29.95

S-100

P100-1 BARE - NO FOIL PADS \$15.15
P100-2 HORIZONTAL BUS \$21.80
P100-3 VERTICAL BUS \$21.80
P100-4 SINGLE FOIL PADS PER HOLE \$22.75

APPLE

P500-1 BARE - NO FOIL PADS \$15.15
P500-3 HORIZONTAL BUS \$22.75
P500-4 SINGLE FOIL PADS PER HOLE \$21.80
7060-45 FOR APPLE IIe AUX SLOT \$30.00

SOCKET-WRAP I.D.™

- SLIPS OVER WIRE WRAP PINS
- IDENTIFIES PIN NUMBERS ON WRAP SIDE OF BOARD
- CAN WRITE ON PLASTIC, SUCH AS IC #

PINS	PART#	PCK. OF	PRICE
8	IDWRAP 08	10	1.95
14	IDWRAP 14	10	1.95
16	IDWRAP 16	10	1.95
18	IDWRAP 18	5	1.95
20	IDWRAP 20	5	1.95
22	IDWRAP 22	5	1.95
24	IDWRAP 24	5	1.95
28	IDWRAP 28	5	1.95
40	IDWRAP 40	5	1.95

PLEASE ORDER BY NUMBER OF PACKAGES (PCK. OF)

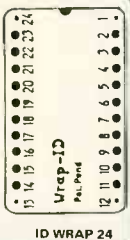

ID WRAP 24

FRAME STYLE TRANSFORMERS

12.6V AC CT	2 AMP	5.95
12.6V AC CT	4 AMP	7.95
12.6V AC CT	8 AMP	10.95
25.2V AC CT	2 AMP	7.95

25 PIN D-SUB GENDER CHANGERS \$7.95



SWITCHING POWER SUPPLIES

PS-IBM \$99.95

- FOR IBM PC-XT COMPATIBLE
- 130 WATTS
- +5V @ 15A, +12V @ 4.2A
- -5V @ .5A, -12V @ .5A
- ONE YEAR WARRANTY



PS-IBM

PS-130 \$99.95

- 130 WATTS
- SWITCH ON REAR
- FOR USE IN OTHER IBM TYPE MACHINES
- 90 DAY WARRANTY



PS-130

PS-A \$49.95

- USE TO POWER APPLE TYPE SYSTEMS
- +5V @ 4A, +12V @ 2.5A
- -5V @ .5A, -12V @ .5A
- APPLE POWER CONNECTOR



PS-A

PS-SPL200 \$49.95

- +5V @ 25A, +12V @ 3.5A
- -5V @ 1A, -12V @ 1A
- UL APPROVED
- ALUMINUM ENCLOSURE



PS-SPL200

PS-TDK \$29.95

- +5V @ 4A, +12V @ 2A
- +12V @ 2.8A, -12V @ .30A
- 6.2" x 7.4" x 1.7", 1.6 LBS.



PS-11951 \$29.95

- MANUFACTURED BY ASTEC
- +5V @ 6A, +12V @ 2A
- +12V @ 1.5A, -12V @ 2A
- 5.0" x 8.0" x 2.0", 1.6 LBS.



NEW BOOKS BY STEVE CIARCIA

BUILD YOUR OWN 280 COMPUTER	\$19.95
CIRCUIT CELLAR VOL 1	\$17.95
CIRCUIT CELLAR VOL 2	\$18.95
CIRCUIT CELLAR VOL 3	\$18.95
CIRCUIT CELLAR VOL 4	\$18.95

MICROCOMPUTER HARDWARE HANDBOOK FROM ELCOMP \$14.95

OVER 800 PAGES OF DATA SHEETS
ON THE MOST COMMONLY USED
ICs. INCLUDES TTL, CMOS, 74LS00,
MEMORY, CPUS, MPU SUPPORT,
AND MUCH MORE!

CAPACITORS

TANTALUM			
1.0µf	15V .35	47µf	35V .45
6.8	15V .70	1.0	35V .45
10	15V .80	2.2	35V .65
22	15V 1.35	4.7	35V .85
.22	35V .40	10	35V 1.00

DISC

10pf	50V .05	680	50V .05
22	50V .05	.001µf	50V .05
27	50V .05	.0022	50V .05
33	50V .05	.005	50V .05
47	50V .05	.01	50V .07
68	50V .05	.02	50V .07
100	50V .05	.05	50V .07
220	50V .05	.1	12V .10
560	50V .05	.1	50V .12

MONOLITHIC

.01µf	50V .14	1µf	50V .18
.047µf	50V .15	.47µf	50V .25

ELECTROLYTIC

RADIAL		AXIAL	
1µf	25V .14	1µf	50V .14
2.2	35V .15	10	50V .16
4.7	50V .15	22	16V .14
10	50V .15	47	50V .20
47	35V .18	100	35V .25
100	16V .18	220	25V .30
220	35V .20	470	50V .50
470	25V .30	1000	16V .60
2200	16V .70	2200	16V .70
4700	25V 1.45	4700	16V 1.25

COMPUTER GRADE 44,000µf 30V 3.95

DATARASE EPROM ERASER \$34.95

- ERASES TWO EPROMS IN 10 MINUTES
- COMPACT-NO DRAWER
- THIN METAL SHUTTER PREVENTS UV LIGHT FROM ESCAPING



1/4 WATT RESISTORS

- 5% CARBON FILM ALL STANDARD VALUES FROM 1 OHM TO 10 MEG. OHM
- 10 PCS same value .05 100 PCS same value .02
- 50 PCS same value .025 1000 PCS same value .015

RESISTOR NETWORKS

SIP	10 PIN	9 RESISTOR	.69
SIP	8 PIN	7 RESISTOR	.59
DIP	16 PIN	8 RESISTOR	1.09
DIP	16 PIN	15 RESISTOR	1.09
DIP	14 PIN	7 RESISTOR	.99
DIP	14 PIN	13 RESISTOR	.99

SPECIALS ON BYPASS CAPACITORS

.01 µf CERAMIC DISC	100/\$5.00
.01 µf MONOLITHIC	100/\$10.00
.1 µf CERAMIC DISC	100/\$6.50
.1 µf MONOLITHIC	100/\$12.50

WISH SOLDERLESS BREADBOARDS

PART NUMBER	DIMENSIONS	DISTRIBUTION STRIPS)	TIE POINTS	TERMINAL STRIP(S)	TIE POINTS	BINDING POSTS	PRICE
WBU-D	.38 x 6.50"	1	100	---	---	---	2.95
WBU-T	1.38 x 6.50"	---	---	1	630	---	6.95
WBU-204-3	3.94 x 8.45"	1	100	2	1260	2	17.95
WBU-204	5.13 x 8.45"	4	400	2	1260	3	24.95
WBU-206	6.88 x 9.06"	5	500	3	1890	4	29.95
WBU-208	8.25 x 9.45"	7	700	4	2520	4	39.95



WBU-208

LITHIUM BATTERY AS USED IN CLOCK CIRCUITS

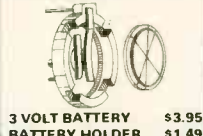

3 VOLT BATTERY \$3.95
BATTERY HOLDER \$1.49

IC MASTER \$79.95



THE INDUSTRY STANDARD

VISIT OUR RETAIL STORE LOCATED AT 1256 SOUTH BASCOM AVENUE IN SAN JOSE



1224 S. Bascom Avenue, San Jose, CA 95128

800-538-5000 • 800-662-6279 (CA) • (408) 995-5430

FAX (408) 275-8415 • Telex 171-110

HOURS: M-W-F, 9-5 TU-TH, 9-9 SAT, 10-3

PLEASE USE YOUR CUSTOMER NUMBER WHEN ORDERING

TERMS: Minimum order \$10.00. For shipping and handling include \$2.50 for UPS Ground and \$3.50 for UPS Air. Orders over 1 lb. and foreign orders may require additional shipping charges - please contact our sales department for the amount. CA residents must include applicable sales tax. All merchandise is warranted for 90 days unless otherwise stated. Prices are subject to change without notice. We are not responsible for typographical errors. We reserve the right to limit quantities and to substitute manufacturer. All merchandise subject to prior sale.

PARTIAL LISTING ONLY — CALL FOR A FREE CATALOG

DISK DRIVES FOR APPLE COMPUTERS

AP-150
\$99.95



- 1/2 HT. DIRECT DRIVE
- 100% APPLE COMPATIBLE
- SIX MONTH WARRANTY

BAL-500
\$129.95



- TEAC MECHANISM-DIRECT DRIVE
- 100% APPLE COMPATIBLE
- FULL ONE YEAR WARRANTY

AP-135
\$129.95



- FULL HT SHUGART MECHANISM
- DIRECT REPLACEMENT FOR APPLE DISK II
- SIX MONTH WARRANTY

MAC535
\$249.95

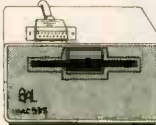

- 3.5" ADD-ON DISK DRIVE
- 100% MACINTOSH COMPATIBLE
- SINGLE SIDED 400K BYT STORAGE
- HIGH RELIABILITY DRIVE
- HAS AUTO-EJECT MECHANISM
- FULL ONE YEAR WARRANTY

AD-3C
\$139.95

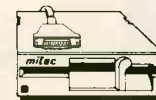

- 100% APPLE IIc COMPATIBLE
- READY TO PLUG IN, W/ SHIELDED CABLE & MOLDED 19 PIN CONNECTOR
- FAST, RELIABLE SLIMLINE DIRECT DRIVE
- SIX MONTH WARRANTY

DISK DRIVE ACCESSORIES
FDD CONTROLLER CARD \$49.95
IIc ADAPTOR CABLE \$19.95
ADAPTS STANDARD APPLE DRIVES FOR USE WITH APPLE IIc

KB-1000 **\$79.95**

- CASE WITH KEYBOARD FOR APPLE TYPE MOTHERBOARD
- USER DEFINED FUNCTION KEYS
 - NUMERIC KEYPAD WITH CURSOR CONTROL
 - CAPS LOCK
 - AUTO-REPEAT



KEYBOARD-AP **\$49.95**

- REPLACEMENT FOR APPLE II KEYBOARD
- CAPS LOCK KEY, AUTO-REPEAT
- ONE KEY ENTRY OF BASIC OR CP/M COMMANDS



EXTENDER CARDS

IBM-PC	\$45.00
IBM-AT	\$68.00
APPLE II	\$45.00
APPLE IIe	\$45.00
MULTIBUS	\$86.00

APPLE COMPATIBLE INTERFACE CARDS

EPROM PROGRAMMER \$59.95

MODEL RP525

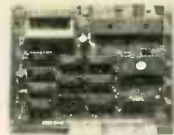

- DUPLICATE OR BURN ANY STANDARD 27x SERIES EPROM
- EASY TO USE MENU-DRIVEN SOFTWARE IS INCLUDED
- MENU SELECTION FOR 2716, 2732, 2732A, 2764 AND 27128
- HIGH SPEED WRITE ALGORITHM
- LED INDICATORS FOR ACTIVITY
- NO EXTERNAL POWER SUPPLY NEEDED
- ONE YEAR WARRANTY

16K RAMCARD \$39.95



- FULL TWO YEAR WARRANTY
- EXPAND YOUR 48K APPLE TO 64K
- USE IN PLACE OF APPLE LANGUAGE CARD

BARE PC CARD W/ INSTRUCTIONS \$9.95

IC TEST CARD \$99.95



- QUICKLY TESTS MANY COMMON ICs
- DISPLAYS PASS OR FAIL
- ONE YEAR WARRANTY
- TESTS: 4000 SERIES CMOS, 74HC SERIES CMOS, 7400, 74LS, 74L, 74H & 74S

3008 MODEM \$49.95

FOR APPLE OR IBM
INCLUDES ASCII PRO-EZ SOFTWARE



- FCC APPROVED
 - BELL SYSTEMS 103 COMPATIBLE
 - INCLUDES AC ADAPTOR
 - AUTO-DIAL/AUTO-ANSWER
 - DIRECT CONNECT
- CABLE FOR APPLE IIc \$14.95**

JOYSTICK CR-401 \$7.95

FOR ATARI 400, 800, 2600,
VIC 20/64 AND APPLE IIe

DISKFILE

HOLDS 70 5 1/4" DISKETTES

\$895



3.5" DISKFILE HOLDS 40 \$99.5

POWER STRIP

UL APPROVED
15A CIRCUIT BREAKER
\$12.95



3-WAY SWITCH BOXES

- SERIAL OR PARALLEL
- CONNECTS 3 PRINTERS TO ONE COMPUTER OR VICE VERSA
- ALL LINES SWITCHES
- HIGH QUALITY ROTARY SWITCH MOUNTED ON PCB
- GOLD CONTACTS
- STURDY METAL ENCLOSURE



SWITCH-3P CENTRONICS PARALLEL \$99.95
SWITCH-3S RS232 SERIAL \$99.95

PRINTER BUFFERS

- FREES COMPUTER FOR OTHER TASKS WHILE PRINTING LONG DOCUMENTS
- STAND-ALONE DESIGN; WORKS WITH ANY COMPUTER OR PRINTER
- ALL MODELS FEATURE PRINT PAUSE MEMORY CHECK, GRAPHICS CAPABILITY

SP120P PARALLEL \$139.95

- 64K UPGRADABLE TO 256K
- LED INDICATOR SHOWS VOLUME OF DATA IN BUFFER

SP120S RS232 SERIAL \$159.95

- 64K UPGRADABLE TO 256K
- 6 SELECTABLE BAUD RATES, FROM 600B-19,200B

SP110P PARALLEL \$249.95

- 64K UPGRADABLE TO 512K
- SPOOLS OUTPUT OF UP TO 3 COMPUTERS
- LED BARGRAPH DISPLAYS AMOUNT OF DATA IN BUFFER
- RESET FUNCTION CLEARS DATA IN BUFFER
- REPEAT FUNCTION CAN PRODUCE MULTIPLE COPIES OF A DOCUMENT



NASHUA DISKETTES DEALS

5 1/4" SOFT SECTOR
DS/DD WITH HUB RINGS

\$990 **69C^{ea}** **59C^{ea}**
BOX OF 10 BULK QTY 50 BULK QTY 250

NASHUA DISKETTES WERE JUDGED TO HAVE THE HIGHEST POLISH AND RECORDED AMPLITUDE OF ANY DISKETTES TESTED ACCORDING TO "COMPARING FLOPPY DISKS", BYTE 9/84

DISKETTES NASHUA 5 1/4"

N-MD2D DS/DD SDFT \$9.90
N-MD2F DS/QUAD SOFT \$34.95
N-MD2H DS/HD FDR AT \$49.95

NASHUA 8"

N-FD1 SS/DD SOFT \$27.95
N-FD2D DS/DD SDFT \$34.95

NASHUA 3.5"

N-3.5SS 3.5" SS/DD FOR MAC \$32.95

VERBATIM 5 1/4"

V-MD1D SS/DD SDFT \$23.95
V-MD2D DS/DD SOFT \$29.95
V-MD110D SS/DD 10 SECTOR HARD \$23.95

TEST EQUIPMENT FROM JDR INSTRUMENTS

DIGITAL MULTIMETER PEN DPM-1000

AUTO RANGING, POLARITY AND DECIMAL!

\$54.95

- LARGE 3.5 DIGIT DISPLAY
- DATA HOLD SWITCH FREEZES READING
- FAST, AUDIBLE CONTINUITY TEST
- LOW BATTERY INDICATOR
- OVERLOAD PROTECTION



20MHZ DUAL TRACE OSCILLOSCOPE

MODEL 2000

\$389.00

35MHZ DUAL TRACE OSCILLOSCOPE

MODEL 3500

\$549.00

FOR MORE INFORMATION ON THE OSCILLOSCOPES, SEE THE BACK COVER.

Canon 160 CPS PRINTER

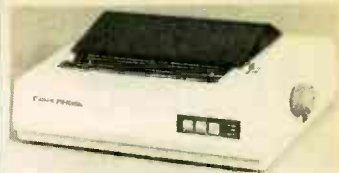

Printed in Draft mode
or Proportional and NLQ

- EPSON/IBM COMPATIBLE CONTROL CODES
- 11 x 9 DOT DRAFT MODE CHARACTERS
- 18 DOTS IN "NEAR LETTER QUALITY"
- 2K PRINT BUFFER
- DOWNLOADING FONT BUFFER
- FAN FOLD, CUT SHEET OR ROLL PAPER
- SOLID "BUSINESS" MACHINE

MODEL PW 1080A

\$199.95

CABLE TO IBM PC \$8.95

5 1/4" FLOPPY DISK DRIVES

TEAC FD-55B 1/2 HT DS/DD (FOR IBM)	\$89.95
TEAC FD-55F 1/2 HT DS/QUAD (FOR IBM)	\$99.95
TEAC FD-55GFV 1/2 HT DS/HD (FOR IBM AT)	\$154.95
TANDON TM100-2 DS/DD (FOR IBM)	\$99.95
TANDON TM50-2 1/2 HT DS/DD (FOR IBM)	\$89.95
MPI-B52 DS/DD (FOR IBM)	\$89.95
QUIME QT-142 1/2 HT DS/DD (FOR IBM)	\$69.95

8" FLOPPY DISK DRIVES

FD 100-8 SS/DD (SA/801 EQUIV)	\$119.00
FD 200-8 DS/DD (ISA/851R EQUIV)	\$159.00

DISK DRIVE ACCESSORIES

TEAC SPECIFICATION MANUAL	\$5.00
TEAC MAINTENANCE MANUAL	\$25.00
1/2 HT MOUNTING HARDWARE	\$2.95
MOUNTING RAILS FOR IBM AT	\$4.95
1/2" POWER CABLE FOR 5 1/4" FDDs	\$2.95
5 1/4" FDD POWER CONNECTORS	\$1.19

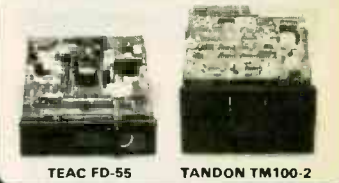

DISK DRIVE ENCLOSURES

CAB-APPLE APPLE TYPE CABINET W/OUT POWER SUPPLY	\$24.95
CAB-1FH5 FULL HT 5 1/4" BEIGE CABINET W/POWER SUPPLY	\$89.95
CAB-2SV5 DUAL SLIMLINE 5 1/4" CABINET W/POWER SUPPLY	\$49.95
CAB-2SV8 VERTICAL DUAL SLIMLINE 8" CABINET W/POWER SUPPLY	\$209.95
CAB-2FH8 HORIZONTAL DUAL FULL HT 8" CABINET W/POWER SUPPLY	\$219.95



CALL FOR VOLUME QUOTES

© COPYRIGHT 1985 JDR MICRODEVICES

CIRCLE 255 ON FREE INFORMATION CARD

BUILD A COMPLETE XT SYSTEM—\$698

XT COMPATIBLE MOTHERBOARD

\$169.00

- 4.77 MHz 8088 CPU, OPTIONAL 8087 CO-PROCESSOR
- 8 EXPANSION SLOTS
- 0K RAM INSTALLED, EXPANDABLE TO 640K ON-BOARD MEMORY
- ALL ICs SOCKETED-HIGHEST QUALITY PC BOARD
- ACCEPTS 2764 OR 27128 ROMS

PRO-BIOS \$29.95

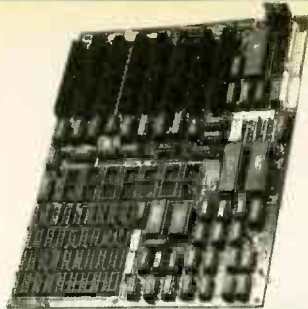

HARD DISK SYSTEMS

Includes short slot HD Controller, cables, mounting hardware and instructions. All drives are pre-tested and come with a one year warranty.

10 Mb \$389
20 Mb \$489

IBM COMPATIBLE INTERFACE CARDS

ALL WITH A ONE YEAR WARRANTY

MULTI I/O FLOPPY CARD \$129.95

PERFECT FOR THE 640K MOTHERBOARD

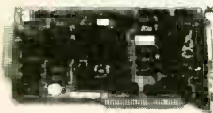

- 2 DRIVE FLOPPY DISK CONTROLLER
- 1 RS232 SERIAL PORT, OPTIONAL 2nd SERIAL PORT
- PARALLEL PRINTER PORT
- GAME PORT
- CLOCK / CALENDAR
- SOFTWARE: CLOCK UTILITIES, RAMDISK, SPOOLER

MULTIFUNCTION CARD \$119.95

ALL THE FEATURES OF AST'S 6 PACK PLUS AT HALF THE PRICE



- CLOCK / CALENDAR
- 0-384K RAM
- SERIAL PORT
- PARALLEL PORT
- GAME PORT
- SOFTWARE INCLUDED
- PRINTER CABLE \$9.95
- 64K RAM UPGRADE 9/\$8.91

COLOR GRAPHICS ADAPTOR \$99.95

FULLY COMPATIBLE WITH IBM COLOR CARD



- 4 VIDEO INTERFACES: RGB, COMPOSITE COLOR, HI-RES, COMPOSITE MONOCHROME, CONNECTOR FOR RF MODULATOR
- COLOR GRAPHICS MODE: 320 x 200
- MONO GRAPHICS MODE: 640 x 200
- LIGHT PEN INTERFACE

MONOCHROME GRAPHICS CARD \$119.95

FULLY COMPATIBLE WITH IBM MONOCHROME ADAPTOR & HERCULES GRAPHICS



- LOTUS COMPATIBLE
- TEXT MODE: 80 x 25
- GRAPHICS MODE: 720 x 348
- PARALLEL PRINTER INTERFACE
- OPTIONAL SERIAL PORT \$19.95

MONOCHROME ADAPTOR \$49.95

ANOTHER FANTASTIC VALUE FROM JDR!

- IBM COMPATIBLE TTL OUTPUT
 - 720 x 350 PIXEL DISPLAY
- PLEASE NOTE: THIS CARD WILL NOT RUN LOTUS GRAPHICS AND DOES NOT INCLUDE A PARALLEL PORT

FLOPPY DISK DRIVE ADAPTOR \$49.95



- INTERFACES UP TO FOUR STANDARD FDDs TO IBM PC OR COMPATIBLES
- INCLUDES CABLE FOR TWO INTERNAL DRIVES
- STANDARD DB37 FOR EXTERNAL DRIVES
- RUNS QUAD DENSITY DRIVES WHEN USED WITH JFORMAT

EASYDATA 1200 BAUD MODEM FOR IBM

INCLUDES PC TALK III COMMUNICATIONS SOFTWARE



- HAYES COMPATIBLE
- AUTO DIAL / AUTO ANSWER
- AUTO RE-DIAL ON BUSY
- INCLUDES SERIAL PORT!
- ONE YEAR WARRANTY

\$169.95

CRT MONITORS FOR ALL APPLICATIONS



TAXAN RGB VISION III MODEL 415

- MADE FOR TAXAN BY ACORN
- 640 x 262 PIXEL RESOLUTION
- 16 COLORS
- 18 MHZ BANDWIDTH
- 12" BLACK MATRIX
- IBM AND LOTUS COMPATIBLE CABLE FOR IBM \$15.95

\$289.95



SAKATA COMPOSITE COLOR MODEL SC-100

- TOP RATED FOR APPLE
- 13" COMPOSITE VIDEO
- RESOLUTION: 280H x 300V
- INTERNAL AUDIO AMPLIFIER
- ONE YEAR WARRANTY

\$169.95



SAMWOO/ALPHA MONOCHROME MODEL DM-216B

- PERFECT COSMETIC MATCH FOR IBM PC
- IBM COMPATIBLE TTL INPUT
- 12" NON-GLARE SCREEN
- P39 GREEN PHOSPHOR
- HI-RES 22 MHZ BAND WIDTH

\$99.95

BUILD YOUR OWN XT COMPATIBLE SYSTEM!

XT MOTHERBOARD \$169.00
PRO-BIOS \$29.95
64K RAM \$8.91
130 WATT POWER SUPPLY \$89.95
FLIP-TOP CASE \$49.95
DKM-2000 KEYBOARD \$79.95
1/2 HEIGHT DISK DRIVE \$69.95
FLOPPY DISK CONTROLLER \$49.95
MONOCHROME ADAPTOR \$49.95
MONOCHROME MONITOR \$99.95

TOTAL: \$697.51

MONITOR STAND



TILTS AND SWIVELS

ONLY \$12.95

IBM PRINTER CABLE



DB25 TO CENTRONICS SHIELDED CABLE **\$9.95**

IBM STYLE COMPUTER CASE

AN ATTRACTIVE STEEL CASE WITH A HINGED LID FITS THE POPULAR PC/XT COMPATIBLE MOTHERBOARDS

- SWITCH CUT-OUT ON SIDE FOR PC/XT STYLE POWER SUPPLY
- CUT-OUT FOR 8 EXPANSION SLOTS
- ALL HARDWARE INCLUDED

\$49.95



IBM COMPATIBLE KEYBOARDS

DKM-2000 \$79.95

KB-5151 \$99.95



- FULLY IBM COMPATIBLE
- LED STATUS INDICATORS FOR CAPS & NUMBER LOCK
- 83 KEY IDENTICAL TO IBM



- ENHANCED IBM COMPATIBLE
- SEPARATE CURSOR & NUMERIC KEYPADS
- CAPS LOCK & NUMBER LOCK INDICATORS
- IMPROVED KEYBOARD LAYOUT

POWER SUPPLY



NOW ONLY \$89.95

- FOR IBM PC-XT COMPATIBLE
- 130 WATTS
- +5V @ 15A, +12V @ 4.2A
- -5V @ .5A, -12V @ .5A

150 WATT MODEL \$99.95

DISK DRIVES

TANDON TM50-2

\$69.95

- 1/2 HT DS/DD
- IBM COMPATIBLE
- EXTREMELY QUIET!

TEAC FD-55B DS/DD \$89.95
TEAC FD-55F DS/QUAD \$99.95
TEAC FD-55G DS/HD \$154.95
QUME QT-142 DS/DD \$89.95
MOUNTING HARDWARE \$2.95
AT/RAILS \$4.95

JDR Microdevices

1224 South Bascom Avenue, San Jose, CA 95128

800-538-5000 • 800-662-6279 (CA) • (408) 995-5430 • FAX (408) 275-8415 • Telex 171-110

© COPYRIGHT 1985 JDR MICRODEVICES

CIRCLE 266 ON FREE INFORMATION CARD

TOLL FREE
800-854-8230
 CA Residents 714-558-8813

OUR POLICY
 •Surcharge for VISA or Mastercard.
 •Volume purchasing agreements available.
 •Orders subject to availability.
 •Pricing subject to change without notice.
 •ACP Retail Store pricing may vary. Not responsible for typos.

CORPORATE BUYERS CALL HARRY

MAJOR BRAND PRICE BREAKTHRU



DEALER INQUIRIES INVITED

Retail Value \$5000

Save up to 60%

ADVANCED XT

ACP PRICE NOW ONLY!

\$1695.00

Monochrome Monitor Included
 10 Mb Hard Disk

ACP has sold over 2,000 of this system to major customers including Rockwell Int'l, Hughes Aircraft and Emulex Corp. See for yourself why these customers prefer the Advanced XT over the IBM XT.

BASE SYSTEM CONSISTS OF:

- 256K Expandable to 640K on the Motherboard.
- (1) 360K DS/DD Floppy Disk
- Serial & Parallel Ports
- Deluxe Keyboard w/LED's
- Mouse with Software
- LCD, Lightpen & RF Ports
- RGB and Mono Ports
- VLSI Circuit Design
- (3) Expansion Slots
- Ergonomic Design & Packaging
- GEM or PC Works Software
- 90 Day Warranty

SYSTEM A (P/N BDACP100)	Base System (See Left)	\$ 995.00
SYSTEM B (P/N BDACP101)	Base System with additional Floppy Disk Drive	\$1099.00
SYSTEM C (P/N BDACP102)	Base System w/12" Grn Monitor w/Tilt & Swivel base and additional Floppy Drive	\$1295.00
SYSTEM D (P/N BDACP103)	Base System w/RGB Color Monitor w/Tilt & Swivel base and additional Floppy Drive	\$1495.00
SYSTEM E (P/N BDACP104)	Base System w/10Mb Hard Disk and Green Monitor with Tilt & Swivel base	\$1695.00
SYSTEM F (P/N BDACP105)	Base System w/10Mb Hard Disk and RGB Color Monitor with Tilt & Swivel base	\$1985.00

ADVANCED XT ACCESSORIES

- 6 Slot Expansion Chassis (IBM or IBM Compatible) ... **\$399.00**
- LCD Display (80x25) for use with Advanced XT LCD Port. **299.00**
- Monochrome Hi-res text card ... **69.95**
- Monochrome IBM style Monitor. **99.95**
- 256K Upgrade (Uninstalled) ... **59.95**

- PC DOS 2.1 **\$65.00**
- GW Basic **75.00**
- PC Works 1.15 (Touchstone) Regular \$195 **65.00**
- Archive Tape B.U. (ext. 10Mb) **995.00**
- Maintenance Manual **50.00**
- Technical Reference Manual ... **50.00**

SPECIAL SYSTEM w/Printer

1. System E with Diablo 620 Serial Printer. **\$1995.00**
2. System F with Diablo 620 Serial Printer. **2285.00**
3. Canon LBP-8A1 IBM compatible laser printer. Purchase for a low price of **\$2895.00** and we will give you System A **FREE!**

DIABLO 620 DAISYWHEEL PRINTER



The Finest Letter Quality Printer at a Spectacular Price. We have sold 1000's. You can have a spare at this price.

- 620 Serial. List 1495 ACP **\$395.00**
- 620 API. List 1695 ACP **495.00**
- 620 D36. List 1695 ACP **550.00**
- F-21 Sheet Feeder. List 895 ACP **249.00**
- 620 Tractor. List 395 ACP **99.00**
- Cable ACP **29.00**
- Serial to Par. 64K Buffer ... ACP **125.00**



10 Mb \$399.00

Shugart SA712 w/Controller & Cables. Ready for Installation in IBM™ PC and Compatibles. (1 Year Warranty)

Shugart SA712 10Mb HD **\$229.00**

Seagate ST225 20Mb HD **419.00**

PC UPGRADE SPECIAL

\$4.95 SET OF (9) 64K RAMS

\$26.95 SET OF (9) 256K RAMS

\$5.95 4128 PIGGYBACK RAM

1200 Baud Hayes™ Comp. Modem Short Card by U.S. Robotics with Telpac I Software.

List \$499 ACP **\$179.00**

Buy (6) **\$159.00**

10Mb Tape Back-up

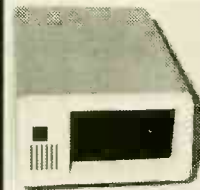

Archive, #1 in tape back-up technology.

High speed 10Mb back-up for only

\$995.00

External Box w/Power Supply

Great for adding Hard Disk to your PC.

Same as photo **\$179.00**

DELUXE JOYSTICK

\$11.95



Compatible w/Atari 2600, 400, 800, VIC-20/64 and Apple. Apple requires optional cable adaptor. Add **\$2.95**

APPLE DISK DRIVE

\$115.00



High quality 1/2 high drive for Apple II, II+, IIe or IIc. Apple IIc requires optional cable adaptor. Add **\$10.00**

CIRCLE 106 ON FREE INFORMATION CARD

Advanced Computer Products Inc.

Mail Order: P.O. Box 17329 Irvine, CA 92713

Retail: 1310 E. Edinger, Santa Ana, CA 92705

cable tv

DESCRAMBLER PARTS!

We stock the exact parts, PC board and AC adaptor for Radio Electronics February 1984 article on building your own **Cable TV Descrambler**.

- #701 **PARTS PACKAGE**.....\$29.95
Includes all the original resistors, capacitors, diodes, transistors, integrated circuits, coils, IF transformers (toko BKAN-K5552AXX).
- #702 **PC BOARD**.....\$12.95
Original etched & drilled silk-screened PC board used in the article.
- #704 **AC ADAPTOR**.....\$12.95
Original (14 volts DC @ 285ma) ac adaptor used in the article.

S P E C I A L S

BOTH #701 & #702..... NOW \$39

ALL THREE #701, #702 & #704 NOW \$49

Add \$2.50 shipping and handling — \$4.50 for Canadian orders
We also offer quantity Discounts on 5 or more units

FREE Reprint of Radio Electronics article (February 1984) on Building Your Own **CABLE TV DESCRAMBLER** with any purchase of above.

**60-CHANNEL
CABLE
CONVERTER**
WITH INFRARED REMOTE CONTROL

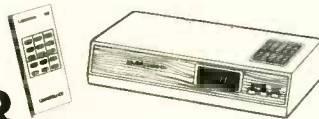

SC-60R CONVERTER.....\$69.95

Thousands of these converters sold nationally for \$119.95
We offer you this same type of converter for only \$69.95
All converters are NEW, with Full manufacturer's WARRANTY.

FEATURES:

- Full 60 Channel Capability
- Cordless Infrared remote control
- Ultra-Stable Synthesized tuning
- Microprocessor controlled PLL
- Works on all TV models, channel 3 output
- Standard/HRC Switch for compatibility with all Cable Systems
- Will work with all types of external descramblers

Add \$3.50 Shipping and Handling
\$4.50 on Canadian Orders

**ORDER
TOLL FREE**

1-800-227-8529

inside MA 617-339-5372
VISA, MASTERCARD or C.O.D.



**J & W
ELECTRONICS, INC.**

P.O. BOX 800R • MANSFIELD, MA 02048

SPARTAN Electronics Inc.
The Communication and Electronic Source



(516) 499-9500
6094 Jericho Tpke.
Commack, N.Y. 11725

GENERAL INSTRUMENT LCC-58
58 Channel Remote Controller

- On/off fine tune
- Wireless
- Installs in minutes

\$79.95



HAYES Smartmodem 1200



\$395.95

- Full or Half Duplex
- 300 BPS or up to 1200 BPS operation
- Auto Answer and Auto Dial
- Connects directly to telephone lines

CARROL TOUCH 232LT Line Tester

- 24 line accessibility
- True tri-state monitoring
- Dual color Led's (red, green)
- No battery required
- Complete Accessories:

\$159.95



Durable case, reference card, 2 "Y" jumper cables, 6 straight jumper cables, 10' male to female RS232C extension cable, and an operator's manual

NEW 12" DIAGONAL MONITOR

- Monochrome display
- Composite video
- 80 characters & 25 lines
- 700 line resolution at center
- Non-glare CRT

Green **\$92.95**



Amber **\$97.95**

PHILIPS REMOTE CABLE CONVERTER



\$125.00

- Micro computer technology
- Quartz controlled IC's lock in picture & prevent drift
- 60 channel selection
- Programmable time on & off
- 24 hour LED digital clock
- Favorite channel memory & recall plus scan
- Wireless hand held "infra-red" transmitter system
- Automatic fine tune
- Adaptable to any brand television
- One year warranty service

RS232 TRANSMISSION LINE TESTER

- Features: Male to Female connector for easy insertion into RS232 Line
- Test 7 Lines (TD, RD, RTS, CTS, DSR, CD, DTR) using LED's to indicate status of each
- Directly powered by RS232 Line no AC power needed.



\$19.95

WELLER Temperature Controlled Soldering Station

- Control Ranges 600 F, 700 F, 800 F
- Change temperature by simply changing the heat sensing tip
- Safe for IC Soldering
- Storage Tray for extra tips and tip cleaning sponge with receptacle
- Comes with 1/8" screwdriver tip 700 F.
- 3 wire 4.5" long cord



\$99.95

SGL WABER DATAGARD Spike & Noise Suppressor



\$39.95
PROTECT YOUR COMPUTER WITH DATAGARD

Datagard DG115S provides a single-stage spike filter and a single-stage noise filter to protect against moderate and catastrophic spikes and virtually all unwanted noise interference coming through the wall outlet

Dealers Welcome

We accept MC, Visa, Amex, COD (w \$10 deposit)
Shipping charges as follows

Volume Discounts
Call

76 00 to 250 00	\$2 50
251 00 to 500 00	\$4 50
501 00 to 750 00	\$6 00
751 00 to 1000 00	\$8 50
	\$12 00

(516) 499-9500

Store Hours: Mon-Fri 9-6

TELEX: 551427 SPARTAN

Sat. 9:30-5

ADVERTISING INDEX

RADIO-ELECTRONICS does not assume any responsibility for errors that may appear in the index below.

Free Information Number	Page	117	Mouser	89
— Ad Mart	CD6	—	NRI	16,40
271 A.I.S. Satellite	38	—	NTS	34
108 AMC Sales	28	—	Nesda	95
76 AP Products	31	278	Omnitron	14
— Advanced Electronics	29	—	Pacific Cable	97
106 Advanced Computer Products	116	—	Pamer Electric Surplus	38
107 All Electronics	109	258	PanaVise	38
72 Amazing Devices	104	257	Phoenix Institute of Technology	4
84 Appliance Service	39	269	Probemaster	13
77 B&K Precision	26	280	Prof. Diving School of N.Y.	85
275 Banner Technical Books	89	126	RAG Electronics	5
98 Beckman Industrial	30	78	Radio Shack	108
282 C & S Sales	20	70	Ramsey	99
— CIE	52	259	Saratoga Electronics	102
276,277 Cameo Enterprises	39,87	279	Saucer City	38
54 Chemtronics	10	75	Spartan Electronics	118
— Command Productions	95	267	Tektronix	CV2
79 Communications Electronics	3,33	284	Transleteronic	95
— Coop's Satellite Digest	82	268	U.S. Instrument Rentals	11
283 Copper Electronics	10	66	W.S. Jenks	85
127 Deco Industries	38,39	103	Wm B. Allen	100
264 Deltax Dynamic	39			
95 Dick Smith Electronics	24,25			
82 Digi-Key	105			
— Digital Research Computers	104			
270 Diplomat International	93			
— Educalc Publications	22			
— Electro Math	97			
262 Electronic Parts Outlet	115			
274 Electronics Book Club	21			
— Electronic Technology Today	CD11			
120 Elephant Electronics	39			
111,251 Etronix	28,89			
100 Firestik II	93			
265 Fluke Manufacturing	7			
— Fordham Radio	9,23			
— Grantham College of Engineering	91			
272 Hameg	CV3			
86 Heath	15			
281 Huntron Instruments	39			
— ICS Computer Training	87			
287 Intek Electronics	39			
65 J & W	117			
59 JDR Instruments	CV4			
113,253 JDR Microdevices	110,111			
254,255 JDR Microdevices	112,113			
266 JDR Microdevices	114			
114 Jameco	106,107			
124 James Walter Satellite Rec.	39			
115 Jensen Tools	38			
— Jim-Pak	27			
263 Kepro Circuit Systems	93			
87 MCM Electronics	101			
256 Mark V. Electronics	103			
273 Micro-Mart	98			
71 Morning Distributing	39			

Gernsback Publications, Inc.
500-B Bi-County Blvd.
Farmingdale, NY 11735
(516) 293-3000
President: Larry Steckler
Vice President: Cathy Steckler

ADVERTISING SALES 516-293-3000

Larry Steckler
publisher
Arline Fishman
advertising coordinator
Shelli Weinman
advertising associate
Lisa Strassman
credit manager
Donna Sala
credit associate
Naomi Matten
advertising assistant

SALES OFFICES

EAST/SOUTHEAST

Stanley Levitan
Eastern Sales Manager
Radio-Electronics
500-B Bi-County Blvd.
Farmingdale, NY 11735
718-428-6037, 516-293-3000

MIDWEST/Texas/Arkansas/Okla.

Ralph Bergen
Midwest Sales Manager
Radio-Electronics
540 Frontage Road—Suite 339
Northfield, IL 60093
312-446-1444

PACIFIC COAST/ Mountain States

Marvin Green
Pacific Sales Manager
Radio-Electronics
15335 Morrison St.—Suite 227
Sherman Oaks, CA 91403
818-986-2001

Two of the best HAMEG-Performers

2 year warranty

high quality at low cost

HM 205 an outstanding new Oscilloscope with Digital Storage

Realtime:

2 channels DC – 20 MHz
max. sensitivity 2 mV/div.
Timebase 0.2 s – 20 ns/div.
Trigger: DC – 35 MHz (0.5 div.)
Built-in Component Tester
1 kHz / 1 MHz calibrator (3 ns)
TV sync. separator

Digital Storage:

max. sampling rate 100 kHz
Refresh-, Single-Mode
Storage: 8 bit x 2048 points
Timebase: 5 s – 0.1 ms/div

CRT 8x10 cm, int. graticule, 2 kV

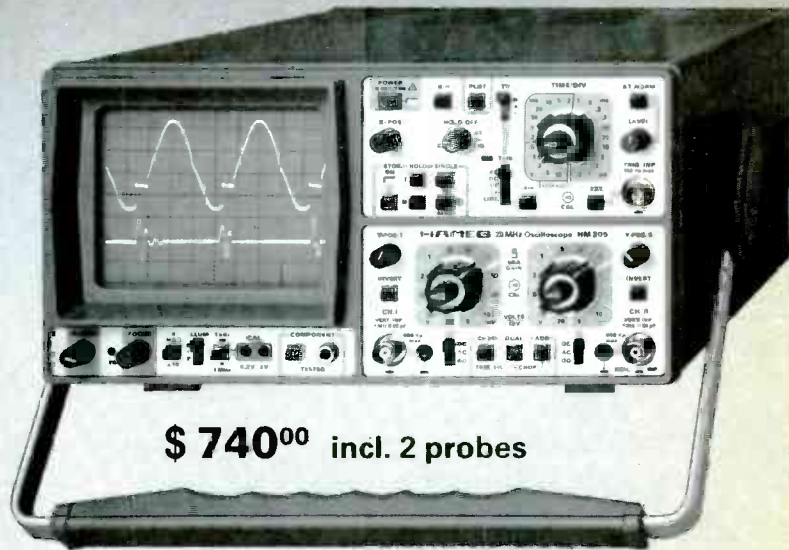

\$ 740⁰⁰ incl. 2 probes

HM 208 the high tech Digital Storage Scope with 20 MHz sampling rate

Realtime:

2 channels DC – 20 MHz
max. sensitivity 1 mV/div.
Timebase 0.1 s – 20 ns/div.
Trigger: DC – 40 MHz (0.5 div.)

Digital Storage:

max. sampling rate 20 MHz
Roll-, Refresh-, Single-, XY-Mode
Storage: 8 bit x 4096 points
Timebase: 50 s – 1 μ s/div.
Pretrigger: 0-25-50-75-100%

CRT 8x10 cm, int. graticule, 14 kV
IEEE-488 Interface Option



\$ 2390⁰⁰ incl. 2 probes

Write or call

HAMEG® Inc.

14 day full money back guarantee

88-90 Harbor Road · Port Washington, N.Y. 11050 · ☎ (516) 883.3837 · TWX (510) 223.0889

CIRCLE 272 ON FREE INFORMATION CARD

PERFORMANCE

THAT IS OUT OF THIS WORLD...



\$389⁰⁰

**MODEL 2000 20MHz
DUAL TRACE**

\$549⁰⁰

**MODEL 3500 35MHz
DUAL TRACE DELAYED SWEEP**

...AT A DOWN TO EARTH PRICE

At last! Truly affordable test equipment with no compromise in design, and features you would expect to find only on oscilloscopes costing hundreds of dollars more! JDR Instruments presents two, new, high-performance models backed by a two year warranty and technical support which is only a phone call away. Perfect for the technician or advanced hobbyist, both models feature Dual Trace capability and a variety of operating and triggering modes, including CH-B Subtract and X-Y operation.

MODEL 2000 has a 20 MHz bandwidth and 20 calibrated sweeps ranging from .2s to .2 μ s. A convenient built-in component tester provides additional diagnostic power.



INCLUDES TWO HIGH QUALITY
1x, 10x TEST PROBES

CIRCLE 59 ON FREE INFORMATION CARD

MODEL 3500 features a 35 MHz bandwidth and exceptional 1mV/DIV sensitivity. Delayed sweep and variable holdoff allow stable viewing of complex waveforms.

**ORDER TOLL FREE
800-538-5000
800-662-6279 (CA)**

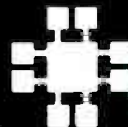

JDR INSTRUMENTS

1224 South Bascom Avenue
San Jose, California 95128 (408) 995-5430